

***DSAENCL4000***  
***RACK MOUNT ENCLOSURE &***  
***DSA3016 PRESSURE***  
***SCANNERS***

***HARDWARE AND SOFTWARE MANUAL***  
***SOFTWARE VERSION 5.27***



***Scanivalve***





# PREFACE

## WARNINGS, CAUTIONS, AND NOTES



WARNING

The WARNING! symbol indicates that danger of injury to persons and the environment and/or considerable damage (mortal danger, danger of injury) could occur if the respective safety precautions are not taken.



CAUTION

The CAUTION! symbol indicates danger to the system and material if the respective safety precautions are not taken.



The ESD note symbol indicates that proper precautions for handling Electrostatic Sensitive Devices need to be taken when performing the related operation. This includes the use of grounded work surfaces and personal wrist straps to prevent damage to sensitive electronic components.

## WARRANTY

Scanivalve Corporation, Liberty Lake, Washington, hereafter referred to as Seller, warrants to the Buyer and the first end user that its products will be free from defects in workmanship and material for a period of twelve (12) months from date of delivery. Written notice of any claimed defect must be received by Seller within thirty (30) days after such defect is first discovered. The claimed defective product must be returned by prepaid transportation to Seller within ninety (90) days after the defect is first discovered. Seller's obligations under this Warranty are limited to repairing or replacing, at its option, any product or component part thereof that is proven to be other than as herein warranted.

Surface transportation charges covering any repaired or replacement product or component part shall be at Seller's expense; however, inspection, testing and return transportation charges covering any product or component part returned and redelivered, which proves

not to be defective, shall be at the expense of Buyer or the end user, whomever has returned such product or component part.

This Warranty does not extend to any Seller product or component part thereof which has been subjected to misuse, accident or improper installation, maintenance or application; or to any product or component part thereof which has been repaired or altered outside of Seller's facilities unless authorized in writing by Seller, or unless such installation, repair or alteration is performed by Seller; or to any labor charges whatsoever, whether for removal and/or reinstallation of the defective product or component part or otherwise, except for Seller's labor charges for repair or replacement in accordance with the Warranty. Any repaired or replacement product or component part thereof provided by Seller under this Warranty shall, upon redelivery to Buyer, be warranted for the unexpired portion of the original product warranty.

THIS WARRANTY IS IN LIEU OF AND EXCLUDES ALL OTHER WARRANTIES, EXPRESSED OR IMPLIED, ARISING BY OPERATION OF LAW OR OTHERWISE, INCLUDING THE IMPLIED WARRANTIES OF MERCHANTABILITY AND FITNESS FOR A PARTICULAR PURPOSE, AND IN NO EVENT SHALL SELLER BE LIABLE FOR INCIDENTAL OR CONSEQUENTIAL DAMAGES.

In the event of a failure:

1) Notify Scanivalve Corporation, Customer Service Department. Include model number and serial number. On receipt of this information, service data or shipping instructions will be forwarded. This may be transacted by telephone or e-mail.

2) On receipt of shipping instructions, forward the product, transportation prepaid. Repairs will be made and the product returned.

3) All shipments should be made via "Best Way." The product should be shipped in the original packing container or wrapped in protective material and surrounded by a minimum of four (4) inches of a shock absorbing material.

**TRADEMARKS ® AND COPYRIGHTS ©**

Scanivalve is a registered trademark of Scanivalve Corporation.

Swagelok® is a registered trademark of Swagelok Company.

All other brand and product names are trademarks or registered trademarks of their respective companies.

**PACKAGING FOR SHIPMENT**

If the product must be shipped, whether being returned to Scanivalve or relocated to another location, it must be packaged properly to minimize the risk of damage. The recommended method of packing is to place the instrument in a container, surrounded on all sides with at least four inches of shock attenuating material such as Styrofoam peanuts.

**IMPORTANT NOTICE**

Please note that the product specifications and other information contained in this manual are subject to change without notice. Scanivalve Corporation makes an effort and strives to provide complete and current information for the proper use of the equipment. If there are any questions regarding this manual or the proper use of the equipment, contact Scanivalve Corporation.

**CONTACT INFORMATION**

If there are any questions or concerns regarding any Scanivalve product, please do not hesitate to contact us at the following:

Scanivalve Corp.  
1722 N. Madson Street  
Liberty Lake, WA 99019  
Telephone: (800)935-5151 (509)891-9970  
Fax: (509)891-9481  
scanco@scanivalve.com  
www.scanivalve.com

Scanivalve Corporation is an ISO 9001:2015 certified company.

This page is intentionally left blank

# TABLE OF CONTENTS

---

|  |           |
|--|-----------|
| <b>PREFACE</b>   | <b>IV</b> |
| Warnings, Cautions, and Notes                            | iv        |
| Warranty   | iv        |
| Trademarks ® and Copyrights ©                            | v         |
| Packaging for Shipment                                   | v         |
| Important Notice   | v         |
| Contact Information                                      | v         |
| <br>   |           |
| <b>SECTION 1: SPECIFICATIONS</b>                         | <b>8</b>  |
| DSAENCL4000 General Specifications                       | 8         |
| DSAENCL4000 Environment Specifications                   | 8         |
| DSA3016 General Specifications                           | 9         |
| <br>   |           |
| <b>SECTION 2: INTRODUCTION</b>                           | <b>11</b> |
| DSAENCL4000 General Description                          | 11        |
| DSA3016 General Description                              | 11        |
| DSAENCL4000/DSA3016 Environmental Considerations         | 11        |
| DSA3016 Configurations                                   | 12        |
| DSA3016/16Px   | 12        |
| DSA3016/16Px Dual Range                                  | 12        |
| DSA3016/16Dpx Differential and DSA3016/8DPx Differential | 13        |
| <br>   |           |
| <b>SECTION 3: OPERATION</b>                              | <b>15</b> |
| Unpack & Inventory                                       | 15        |
| Mounting   | 15        |
| Warm-Up  | 15        |
| Modules  | 15        |
| ENCL4000 Power Requirements                              | 15        |
| Surge Protection   | 15        |
| Surge Protector Ratings                                  | 15        |
| Clamping voltage   | 15        |
| Energy Absorption/Dissipation                            | 15        |
| Response time  | 15        |
| Indicator Light  | 15        |
| Communication  | 16        |
| Setting Up an Ethernet Connection                        | 16        |
| Using a Static IPv4 address                              | 16        |
| Client/Host Options                                      | 17        |
| PC - TCP/IP  | 17        |
| PC - UDP   | 17        |
| PC - ScanTel   | 17        |
| PC - LabVIEW Configuration Utility                       | 17        |
| PC - LabVIEW Development Kit                             | 17        |
| PC - HyperTerminal                                       | 17        |
| Scanning   | 18        |

|   |           |
|---|-----------|
| Scan Rate   | 18        |
| Scan Duration   | 18        |
| Scan Data Format  | 18        |
| Scan Data Units   | 18        |
| Starting a Scan   | 18        |
| Scanning with an External Trigger                         | 19        |
| Setting up an External Frame Trigger                      | 19        |
| Scan Data Output Methods                                  | 19        |
| ASCII TCP Scan Data Transfer                              | 19        |
| Binary TCP Scan Data Transfer                             | 20        |
| Binary UDP Scan Data Transfer                             | 20        |
| FTP Scan Data Transfer                                    | 20        |
| IEEE1588v2 Precision Time Protocol                        | 20        |
| Zero Offset Calibrations                                  | 21        |
| Differential Modules                                      | 21        |
| Purging   | 22        |
| <br>  |           |
| <b>SECTION 4: HARDWARE</b>                                | <b>23</b> |
| Pneumatic Connections                                     | 23        |
| Making 1/16" Tubulation Connections                       | 23        |
| Making SwageLok® Compression Connections                  | 23        |
| Pressure Measurement(Px) Ports                            | 24        |
| Calibration (CAL) Port                                    | 24        |
| Reference (REF) Port                                      | 24        |
| Control 1 (CTL1) Port (DOUT6)                             | 24        |
| Control 2 (CTL2) Port (DOUT 7)                            | 24        |
| Purge Control (PRGCTL) Port (DOUT 8)                      | 24        |
| Purge Supply (PRG) Port                                   | 24        |
| DSA Calibration Valve                                     | 24        |
| DSA3016 Back Block Configurations                         | 25        |
| ECNL4000 Electrical Connections                           | 26        |
| Ethernet Connection                                       | 26        |
| Serial Connections  | 26        |
| Digital I/O Connections                                   | 26        |
| DSA3016 Electrical Connections                            | 27        |
| DSA3016 ID Chip and ID Switch                             | 27        |
| <br>  |           |
| <b>SECTION 5: SOFTWARE</b>                                | <b>29</b> |
| Overview  | 29        |
| ENCL Commands   | 29        |
| COMMAND FORMAT  | 30        |
| Command List  | 31        |
| Auxiliary command   | 31        |
| A/D Calibration (Non-Temperature Compensated)             | 31        |
| A/D Calibration (Temperature Compensated)                 | 32        |
| A/D Coefficient Calculation (Non-Temperature Compensated) | 32        |
| A/D Coefficient Calculation (Temperature Compensated)     | 33        |
| Bootloader version  | 33        |
| Calibrate   | 33        |
| Calibrate Insert  | 34        |



|   |    |
|---|----|
| Calibrate Zero  | 35 |
| Calibrator Command                                      | 35 |
| Channel   | 36 |
| Clear   | 36 |
| Control Pressure Reset                                  | 37 |
| Create Sensor Profile File                              | 37 |
| Delete  | 38 |
| Delete file   | 38 |
| Delta   | 39 |
| Digital input Status                                    | 40 |
| Digital Output Status                                   | 40 |
| Disconnect from host                                    | 40 |
| Error   | 41 |
| Fill  | 41 |
| Frame Trigger   | 42 |
| Insert  | 42 |
| List All Conversion Coefficients                        | 43 |
| List A/D Correction Table (Non-Temperature Compensated) | 44 |
| List Calibration Variables                              | 45 |
| List Bootloader Group Variables                         | 46 |
| List Digital Variables                                  | 46 |
| List File Contents                                      | 47 |
| List Files  | 48 |
| List Gain Variables                                     | 49 |
| List ID Chip Identification                             | 50 |
| List ID Chip Settings                                   | 51 |
| List Identification Variables                           | 52 |
| List Master Conversion Coefficients                     | 53 |
| List Module Information Variables                       | 54 |
| List Network Attached Storage Variables                 | 55 |
| List Offset Variables                                   | 56 |
| List Profile List                                       | 57 |
| List System Components                                  | 58 |
| Merge Sensor Profile File                               | 60 |
| Reboot  | 60 |
| Restart   | 60 |
| Reset Sequence Number                                   | 61 |
| Purge   | 61 |
| Save  | 62 |
| Save Boot Loader Variables                              | 63 |
| Save Network Attached Storage Variables                 | 63 |
| Scan  | 64 |
| Set   | 64 |
| Shutdown  | 64 |
| Slots   | 65 |
| Status  | 66 |
| Stop  | 66 |
| Temperature   | 67 |
| Temperature Gradient Compensation                       | 68 |
| Time Availability Test                                  | 69 |
| Version   | 69 |
| Write ID Chip Variables                                 | 70 |
| Zero  | 71 |
| Configuration Variables                                 | 72 |

|   |    |
|---|----|
| Scan Variables (Group S)                          | 72 |
| ADTRIG  | 72 |
| Scantrig  | 72 |
| BINADDR   | 72 |
| FM  | 73 |
| IFC   | 73 |
| Period  | 73 |
| Qpkts   | 73 |
| Temppoll  | 74 |
| Timestamp   | 74 |
| Conversion Variables (Group C)                    | 75 |
| ZC  | 75 |
| A2DCOR  | 75 |
| BIN   | 75 |
| CALAVG  | 75 |
| CALPER  | 76 |
| CALZDLY   | 76 |
| CVTUNIT   | 76 |
| EU  | 76 |
| FILLONE   | 77 |
| MAXEU   | 77 |
| MINEU   | 77 |
| STARTCALZ   | 77 |
| UNITSCAN  | 78 |
| Digital Output Configuration Variables (Group D)  | 79 |
| DLYPG   | 79 |
| DLYPGSEQ  | 79 |
| DOUTCALZ  | 79 |
| DOUTPG  | 79 |
| DOUTPGSEQ   | 80 |
| DOUTPU  | 80 |
| DOUTSCAN  | 80 |
| DOUTREADY   | 80 |
| BANKA   | 81 |
| BANKB   | 81 |
| BANKUSR   | 81 |
| Scan Group Configuration Variables (Group 1 Only) | 82 |
| AVG1  | 82 |
| CHAN1   | 82 |
| FPS1  | 83 |
| SGENABLE1   | 83 |
| Module Configuration variables (M1 through M8)    | 84 |
| ENABLE  | 84 |
| HPRESS  | 84 |
| LPRESS  | 84 |
| MODTEMP   | 84 |
| NEGPTS  | 85 |
| NPR   | 85 |
| NUMPORTS  | 85 |
| TYPE  | 85 |
| Module Profile Variables (Group P)                | 86 |
| ENCLSN  | 86 |
| SN  | 86 |

|  |     |
|--|-----|
| Identification Configuration Variables (Group I)             | 87  |
| NL   | 87  |
| ECHO   | 87  |
| AUX  | 87  |
| FORMAT   | 88  |
| AUXSCHED   | 88  |
| CAL  | 89  |
| CALSCHED   | 89  |
| CONOUT   | 89  |
| HAVENET  | 89  |
| IFUSER   | 90  |
| NETIN  | 90  |
| NETOUT   | 90  |
| RESCAN   | 90  |
| TWOAD  | 90  |
| IPADD  | 91  |
| SUBNET   | 91  |
| MAC  | 91  |
| LOGIN  | 91  |
| PASSWORD   | 92  |
| LOGIN1   | 92  |
| PASSWORD1  | 92  |
| ALLOWANON  | 92  |
| APP  | 92  |
| GW   | 93  |
| Network Attached Storage Configuration Variables (Group NAS) | 94  |
| ENNAS  | 94  |
| ENNTP  | 95  |
| FILENAS  | 95  |
| IPNAS  | 95  |
| IPNTP  | 95  |
| PASSNAS  | 95  |
| PATHNAS  | 96  |
| USERNAS  | 96  |
| UTCCOFFSET   | 96  |
| ID Chip Configuration Variables (Group ID)                   | 97  |
| IDP  | 97  |
| Temperature Offset Variables (Group O)                       | 99  |
| TEMPBn   | 99  |
| Temperature Gain Variables (Group G)                         | 99  |
| TEMPMn   | 99  |
| ENCL ID Chip Data Format                                     | 100 |
| Permanent Memory Data Format                                 | 100 |
| EEPROM Memory Data Format                                    | 101 |
| PTP Variables (Group PTP)                                    | 103 |
| Enable PTP   | 103 |
| STAT   | 103 |
| SST  | 103 |
| SSD  | 104 |
| UTCOffset  | 104 |
| Domain   | 104 |
| PTP Commands   | 105 |

|   |            |
|---|------------|
| Get Time  | 105        |
| Set Time  | 105        |
| Get UTC Offset  | 105        |
| Display PTP Statistics  | 106        |
| Clear Accumulated PTP Statistical Data                              | 106        |
| <b>Scanivalve DSP Boot Loader</b>                                   | <b>109</b> |
| FTP   | 109        |
| Boot Loader and Application File System                             | 109        |
| DIP Switch Settings   | 109        |
| Bootloader Commands   | 109        |
| <b>DSAENCL Profile File</b>   | <b>111</b> |
| <b>Module Profile File</b>  | <b>111</b> |
| <b>DSAENCL4000 Data Selection Chart</b>                             | <b>112</b> |
| Notes for the Data Selection Chart                                  | 113        |
| <b>ASCII Data Transfer</b>  | <b>113</b> |
| <b>ASCII Scan Data</b>  | <b>113</b> |
| <b>Binary Scan Packets</b>  | <b>114</b> |
| Table 1: Binary Scan Packet   | 114        |
| Table 2: Channel Data   | 114        |
| Table 3: Channel Data with Header                                   | 114        |
| Table 4: Binary Scan Header Packet                                  | 115        |
| Table 5: Binary Scan Packet with PTP Time                           | 115        |
| <br>  |            |
| <b>SECTION 6: MAINTENANCE</b>                                       | <b>116</b> |
| <b>Special Procedures</b>   | <b>116</b> |
| Internet Explorer Setup   | 116        |
| DSAENCL4000 Firmware Installation (Windows 7, 8, 10)                | 117        |
| DSAENCL4000 Calibration Coefficient Installation (Windows 7, 8, 10) | 117        |
| Formatting Flash Memory   | 118        |
| Changing the IP Address   | 118        |
| <b>Special Hardware</b>   | <b>119</b> |
| Hard Disk Drive   | 119        |
| Cooling Fan   | 119        |
| <b>DSAENCL4000 Assembly Details</b>                                 | <b>119</b> |
| <br>  |            |
| <b>APPENDIX</b>   | <b>121</b> |
| Appendix A - Temperature Compensated Pressure Conversion            | 121        |
| Appendix B - Engineering Unit Conversion Constants                  | 122        |
| Appendix C - Software Revision List                                 | 123        |

This page is intentionally left blank

# SECTION 1: SPECIFICATIONS

## DSAENCL4000 GENERAL SPECIFICATIONS

|                              |   |
|------------------------------|---|
| Size (WxHxD)                 | 19.0" x 15.0" x 8.75"<br>(48.26cm x 38.1cm x 22.23cm)                             |
| Weight                       |   |
| Enclosure only               | 19lbs (8.6kg)   |
| With 8 FA modules            | 51.5lbs (23.4kg)  |
| With 8 RA modules            | 73lbs (33.11kg)   |
| DSA Modules Supported        | 8 (16 channel each)   |
| Total Channel Inputs         | 128 individual channels   |
| Communication Protocol       |   |
| Primary Configuration        | Ethernet 10/100Base-T<br>RS232  |
| Communication Configurations |   |
| Ethernet                     | TCP/IP, UDP, FTP,<br>IEEE1588v2   |
| RS232                        | 9600 BAUD, 8 data bits, 1<br>stop bit, no parity<br>(used only for configuration) |

### Maximum Data Throughput (EU)\*

|              |               |
|--------------|---------------|
| Binary       | 625Hz/channel |
| Binary w/PTP | 312Hz/channel |
| ASCII        | 50Hz/channel  |

\* Data rate may be limited by network

|                    |                                    |
|--------------------|------------------------------------|
| Power Requirements | 115 or 230 Vac, 50/60Hz<br>(100Va) |
|--------------------|------------------------------------|

## DSAENCL4000 ENVIRONMENT SPECIFICATIONS

|                       |                                 |
|-----------------------|---------------------------------|
| Operating Temperature | 0 to 60 °C                      |
| Storage Temperature   | -20 to 75°C                     |
| Operating Humidity    | 5 to 95% RH<br>(Non-Condensing) |
| Storage Humidity      | 5 to 95% RH<br>(Non-Condensing) |

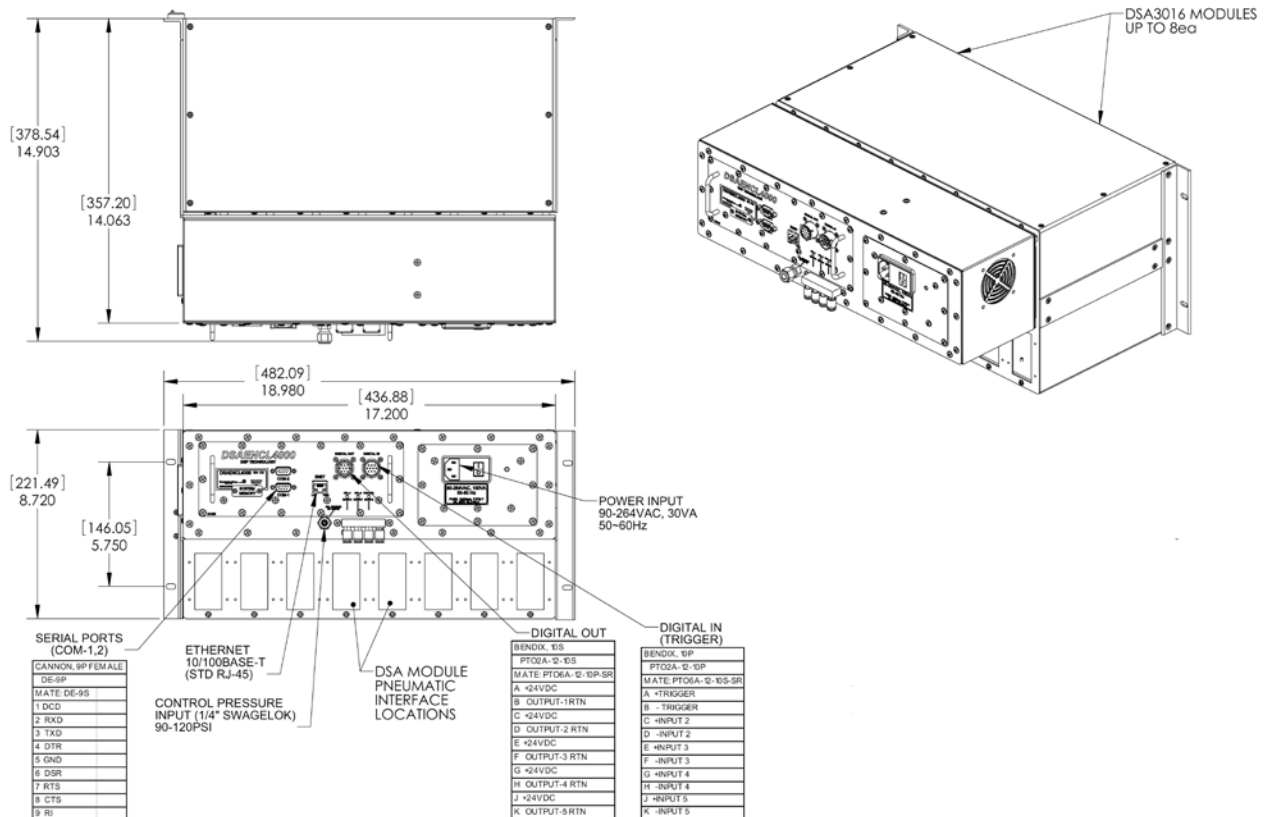

FIGURE 1: DSAENCL4000 DIMENSIONAL DRAWING

**DSA3016 GENERAL SPECIFICATIONS**

|                            |                   |                          |                                  |
|----------------------------|-------------------|--------------------------|----------------------------------|
| Weight:                    |                   | Output:                  | ±2.5Vdc                          |
| Rear Access                | 4.75lbs (2.16kg)  | Power Requirements:      | +15Vdc, 100mA                    |
| Front Access               | 5.5lbs (2.5kg)    |                          | -15Vdc, 25mA                     |
| Channel Inputs (Px):       |                   | Connector Type:          | Amphenol                         |
| Standard (Px)              | 16                |                          | 22221-401(117)                   |
| True Differential (DPx)    | 8                 | Temperature Sensitivity: |                                  |
| Individual Ref (IR)        | 16                | Less than 1PSI           | Zero 0.009% FS/°C                |
| Input Fittings (typical)*: |                   | Greater than 1PSI        | Span 0.007% FS/°C                |
| Front Access               | 1/8" Compression  |                          | Zero 0.009% FS/°C                |
| Rear Access                | 0.063" tubulation | Media:                   | Clean, dry gases compatible with |
|                            | 1/8" Compression  |                          | silicon, silicone, aluminum, and |
|                            | 1/16" Compression |                          | Buna-N                           |

*\*Varies based on front or rear access, and backblock used.*

Full Scale Ranges (Standard):

|              |   |
|--------------|---|
| Differential | ±5"WC, ±10"WC,<br>±20"WC, 1, 2.5, 5, 15,<br>30, 50, 100, 250, 500,<br>750 psid (1.25, 2.5, 5, 7,<br>17, 35, 100, 210, 345,<br>700, 1725, 3500, 5170<br>kPa) |
|--------------|---|

Accuracy (after calibration)\*\*:

|                 |           |
|-----------------|-----------|
| Differential    |           |
| 5 inH2O         | ±0.40% FS |
| 10 inH2O        | ±0.20% FS |
| 20 inH2O        | ±0.20% FS |
| 1.0 psid        | ±0.12% FS |
| 2.5 psid        | ±0.08% FS |
| 5 to 500 psid   | ±0.05% FS |
| 501 to 750 psid | ±0.08% FS |

*\*\*Some combinations of pressure ranges in dual-range modules may dictate a reduction in accuracy*

Overpressure Capacity (No damage):

|                 |       |
|-----------------|-------|
| 5 inH2O         | 2 psi |
| 10 inH2O        | 2 psi |
| 20 inH2O        | 2 psi |
| 1 psid          | 5 psi |
| 2.5 to 499 psid | 200%  |
| 500 psid        | 150%  |
| 750 psid        | 113%  |

Maximum Reference Pressure: 250 psid (1750 kPa) or sensor overpressure, which ever is less

This page is intentionally left blank



# SECTION 2: INTRODUCTION

## DSAENCL4000 GENERAL DESCRIPTION

The DSAENCL4000 is designed to integrate DSA3016 pressure scanning modules into an Ethernet network. Each DSAENCL4000 can accept up to 8 DSA3016 pressure scanners, each with up to 16 inputs.

The DSAENCL4000 is a stand alone pressure scanning system. It incorporates a Microprocessor, RAM, a Micro SD Card (Pre-SN:226) or onboard flash memory (Post SN:226), and other interface boards to scan pressures in Rackmount Electronic Pressure Scanners. These pressures are converted to Engineering Units using the same methods as the Digital Sensor Array.

The DSAENCL4000 may be referred to as DSAENCL, ENCL4000 or ENCL throughout this manual.

The DSA3016 may be referred to as DSA or 3016 throughout this manual.

## DSA3016 GENERAL DESCRIPTION

The DSA3016 is an electronic pressure scanner which can accept up to 16 pneumatic inputs. Each module incorporates up to 16 individual, temperature compensated, piezoresistive pressure sensors. Each pressure sensor is manufactured in a housing designed to facilitate field replacement. No special tools are required to access the sensors.

The sensors are arranged in blocks of eight. Each block of eight sensors has its own individual calibration valve. This valve has four modes of operation: operate, calibrate, purge and leak test. The modes are selected by applying control pressures in a predetermined order. The calibration valve utilizes "Normal Px" valve logic where the valve defaults to the operate mode when no control pressures are applied.

The DSA3016 electronic pressure scanning module is specifically designed for use in applications where long calibration intervals are required. The DSA3016 temperature compensated pressure sensors are compensated from 0 to 50 °C. This is further enhanced by the use of a constant current source for sensor excitation.

## DSAENCL4000/DSA3016 ENVIRONMENTAL CONSIDERATIONS

The DSAENCL4000 is constructed with a rugged steel case. The DSAENCL4000 is furnished with a set of mounting ears so the unit may be mounted in a standard 19 inch rack.

If the DSAENCL4000 could be subjected to shock and vibration levels above 5 g's, a 19" enclosure with shock mounts or a floating shock rack must be used.

It is also recommended that rack rail supports (attached from front rail to back rail, under the ENCL) are used to support the weight of the ENCL.

Section 1: Specifications shows the mounting dimensions and details.



**FIGURE 2.1 - DSA3016 MODULE**

**DSA3016 CONFIGURATIONS**

The DSA3016 is available in three basic configurations, standard, dual range, and differential.

**DSA3016/16Px**

The basic DSA3016/16Px module provides 16 channels of the same ‘gauge’ pressure range sensors. These 16 pressure transducers are configured into two (2) groups of eight (8) each. Each group of eight (8) transducers share a common calibration valve and a common reference manifold. Single range modules tie the two reference manifolds together and the two calibration valves to provide the user with a single reference and a single calibration port to connect to. Figure 2.2 depicts the front panel of a DSA3016/16Px Front Access as well as a rear access.

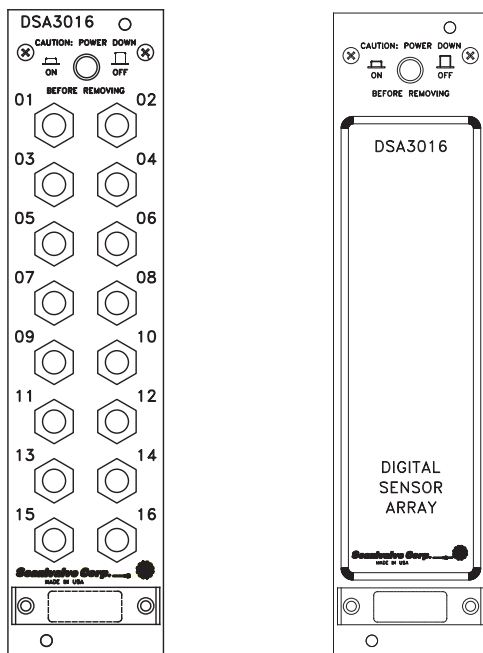

**FIGURE 2.2 - DSA3016/16Px FRONT ACCESS AND DSA3016/16Px REAR ACCESS**

**DSA3016/16Px DUAL RANGE**

The DSA3016/16Px module is available as a dual-range module, offering eight (8) channels of one pressure range and eight (8) channels of a different pressure range. Like a standard DSA3016, each group of eight (8) transducers share a common calibration valve and a common reference manifold. However, in dual range modules the reference manifolds and the calibration valves are not tied together and separate reference and calibration ports are provided on the rear of the module. Figure 2.3 depicts the front panel of a DSA3016/16Px Dual Range Front Access as well as a rear access.

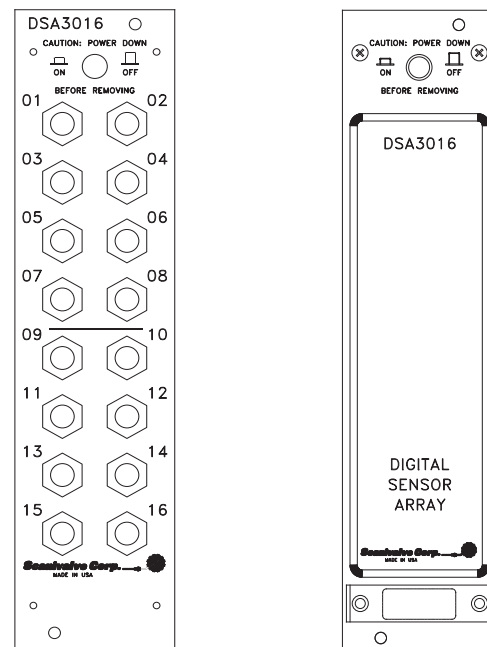

**FIGURE 2.3 - DSA3016/16Px DUAL RANGE FRONT ACCESS AND DSA3016/16Px DUAL RANGE REAR ACCESS**

**DSA3016/16DPx DIFFERENTIAL AND DSA3016/8DPx DIFFERENTIAL**

For differential pressure measurement applications, the DSA3016 can be configured with eight (8) or sixteen (16) differential pressure transducers. Like the DSA3016/16P<sub>x</sub>, each group of transducers has a dedicated calibration valve that allows the input pressures to be blocked off during any calibration, including a zero offset calibration (CALZ). Figure 2.4 depicts the front panels for a: DSA3016/16DP<sub>x</sub> Front Access, DSA3016/8DP<sub>x</sub> Front Access, and DSA3016/8DP<sub>x</sub> rear access. The DSA3016/16DP<sub>x</sub> configuration is only available as a front access with 1/16" Swagelok® fittings.

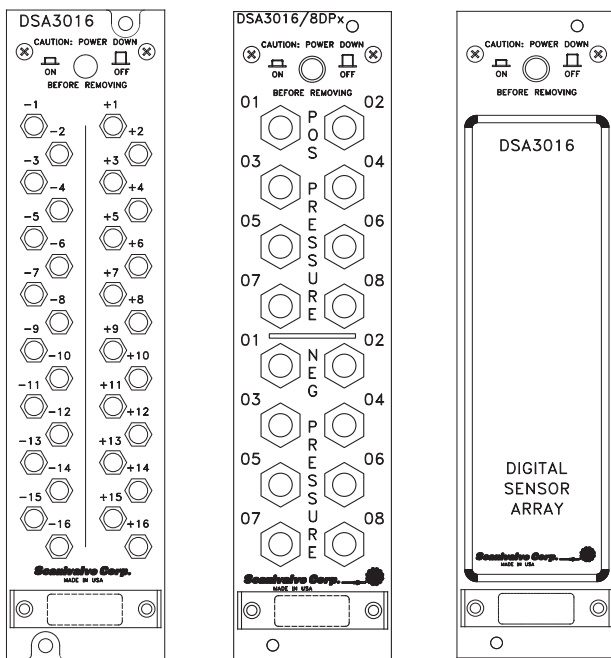
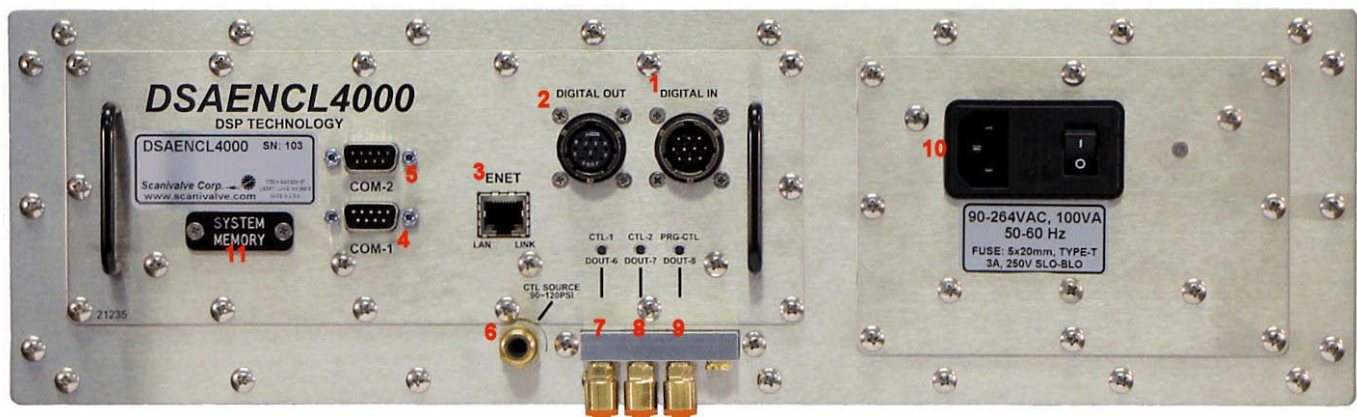

**FIGURE 2.4 - DSA3016/16DP<sub>x</sub> FRONT ACCESS, DSA3016/8DP<sub>x</sub> FRONT ACCESS, DSA3016/8DP<sub>x</sub> REAR ACCESS**

**DSAENCL 4000 REAR PANEL**

The rear panel contains all input and output connections. All connections are clearly marked. The system memory access panel protects the Micro SD card from damage. This card is removable by gently pressing on the accessible edge of the card. The Micro SD card was replaced by an onboard flash chip beginning with SN: 226. The connections are:

1. Digital In - This connector will receive digital inputs from other devices to control or trigger the DSAENCL4000. There are five programmable inputs available. These inputs are configured using the Digital I/O variables.
2. Digital Out - This connector has five digital outputs that may be used to control other external devices or solenoids. There are five programmable outputs available. These outputs are configured using the Digital I/O variables.
3. ENET - The Ethernet connection. A standard RJ45 connector.
4. COM1 - A Serial Connection - this may only be used for Device Communications. Device Communications is communication with an SPC3000 Calibrator or another Auxiliary Serial Device.
5. COM2 - A serial connection. This may be configured for debug operation, Device Communications or Host Communications
6. CTL Source - The input connector for the control pressure input supply pressure.
7. CTL-1 - Control Pressure 1 output to pressure scanners. This is controlled by DOUT6, an internal control that should not be modified by a user.
8. CTL-2 - Control Pressure 2 output to pressure scanners. This is controlled by DOUT7, an internal control that should not be modified by a user.
9. PRG-CTL - Purge Control Pressure Output output to pressure scanners. This is controlled by DOUT8, an internal control that should not be modified by a user.
10. Power In - The AC Power input module.
11. System Memory - This panels provides access to the internal Micro SD memory card on Pre-SN:226 units.



**FIGURE 2.6 - REAR PANEL**

# SECTION 3: OPERATION

## **UNPACK & INVENTORY**

When you first unpack the DSAENCL4000, begin by inspecting and inventorying the contents of the package. If any visible damage is immediately noticed or if any contents are missing, contact Scanivalve before proceeding. Standard units are shipped with the following contents as a minimum:

1. DSAENCL4000
2. Power cable connector
3. Mini Straight Plug
4. Resource Disk

## **MOUNTING**

The DSAENCL4000 is furnished with a set of mounting ears so the unit may be mounted in a standard 19 inch rack. If the DSAENCL4000 could be subjected to shock and vibration levels above 5 g's, a 19" enclosure with shock mounts or a floating shock rack must be used.

Figure 1 in Section 1: Specifications shows the mounting dimensions and details. Ensure that the DSAENCL4000 is mounted in an environment that conforms to the requirements described in "DSAENCL4000/DSA3016 Environmental Considerations" on page 11.



CAUTION! Mounting the DSAENCL4000 inadequately or in an environment that does not conform to the recommendations can result in permanent damage to the module

## **WARM-UP**

After applying power to the DSAENCL4000, a minimum of one hour before collecting data is required to allow the module temperature to become stable. It is recommended that if time allows, the warm-up period should be extended to two hours or more for most applications.

## **MODULES**

The DSAENCL4000 will support any existing DSA3016, ZOC16TC, DSA16EIM, or ZOC16EIM Module. An ID upgrade is required when using the ZOC16EIM modules. DSA3016 Modules should only be inserted or removed with their power switch off. All ZOC modules should only be installed or removed with the DSAENCL4000 power off. Configuration of the DSAENCL4000 may be checked during

warm up. It is very important to verify that the modules are connected to the proper inputs, otherwise data may be invalid

## **ENCL4000 POWER REQUIREMENTS**

The DSAENCL4000 operates from 115 Vac 60 Hz or 230 Vac 50 Hz at 100 VA. It generates  $\pm 15.00$  Vdc, +5.00 Vdc, and +24 Vdc internally. Power connections are made through a Power Entry Module. It is very important to ensure that the cooling fan is operating whenever power is applied to the DSAENCL4000. If the cooling fan is not functioning, the DSAENCL4000 MUST be shut down as soon as possible. The processor will overheat and could be damaged if cooling air flow is lost.

## **SURGE PROTECTION**

A properly sized surge protector must be used with the DSAENCL4000. Scanivalve Corp recommends the use of a device that conforms to the UL 1449, 3rd Edition standard for Surge Protection Devices. The device must have a clamping voltage of 330 V and an energy absorption rating of 600 joules or higher. Surge Protector ratings are described in this section.

### **SURGE PROTECTOR RATINGS**

#### **CLAMPING VOLTAGE**

This is the voltage that will cause the MOVs to conduct electricity to the ground line. A lower clamping voltage indicates better protection. There are three levels of protection in the UL rating - 330 V, 400 V and 500 V. Generally, a clamping voltage more than 400 V is too high.

#### **ENERGY ABSORPTION/DISSIPATION**

This rating, given in joules, describes the amount of energy the surge protector can absorb before it could fail. A higher number indicates greater protection. Good protection is 200 to 400 joules. 600 joules or more offer much better protection.

#### **RESPONSE TIME**

Surge protectors don't react immediately; there is a very slight delay as they respond to the power surge. A longer response time indicates that the enclosure will be exposed to the surge for a greater amount of time. Scanivalve recommends a surge protector that has a response time less than one nanosecond.

#### **INDICATOR LIGHT**

The Surge Protector should have a light to indicate that the protection components are functioning. All MOVs will burn out after repeated power surges.

## **COMMUNICATION**

The DSAENCL4000 is designed primarily for Ethernet communications. This provides a means to configure the DSAENCL4000 as well as scan and collect data from the modules. Two serial ports are also provided. One serial connection is provided for external device support. The other serial connection is designed to be used to configure the module, upload operating system upgrades and provide emergency communications. Several important module variables can be configured through the serial port, but possibly the most important is the Ethernet IP address.

## **SETTING UP AN ETHERNET CONNECTION**

Before an Ethernet connection can be established, the IP address must be configured for the users network. This can be done manually with a static IP address. If a static IP address is desired, the IP address of the ENCL must be set manually. The IP address assigned to the ENCL must be compatible with the network/host computer.

ENCL4000 modules are shipped with a pre-configured IP address that uses the following format:

191.30.46.xxx

The first two octets used are common to all Scanivalve products (191.30). The third octet is the device family code (46). The fourth octet is the last three digits of the ENCL's serial number ("*xxx*" is only a placeholder in the example as all modules will have different serial numbers).

## **USING A STATIC IPV4 ADDRESS**

If a static IP address is desired, the IP address must be manually configured. The IP address that is configured in the ENCL must be compatible with the network that the ENCL is being connected to. If simply connecting the ENCL directly to a host computer, the IP address of the ENCL and the host computer must be compatible, which may require manual configuration of the ENCL and/or computer.

The range of compatible IP addresses is defined by the subnet mask. The standard default subnet mask is 255.255.0.0. This default subnet mask requires that the IP address of the module and host computer must share the first two octets, or sets of numbers. The third and fourth octets of the IP address are variable with this subnet. It is typically recommended that the third octet also be shared between the host computer and the module.

The subnet mask digits of "255" define that the two IP addresses must have matching digits in those positions, and the subnet mask digit of "0" allows the two IP addresses to have unique values for those octets and still be compatible.

No two devices on a single network can share the same IP address. Below are some examples of compatible and non-compatible IP addresses:

Example of matching the first three octets:

Subnet mask: 255.255.255.0  
Host computer: 191.30.46.90  
ENCL module: 191.30.46.100

Example of matching the first two octets:

Subnet mask: 255.255.0.0  
Host computer: 191.30.1.1  
ENCL module: 191.30.46.125

Example of NON-COMPATIBLE IP addresses:

Subnet mask: 255.255.255.0  
Host computer: 191.30.1.1  
ENCL module: 191.30.46.5

When configuring the network, the IP address of the ENCL module can be modified to match the network, or the IP address of the host computer can be modified to be compatible with the ENCL module.

The IP address of a Windows 7, 8, or 10 host computer can be changed\* under:

Control Panel -> Network and Sharing Center -> Local Area Connection/Ethernet -> Properties -> Internet Protocol Version 4 (TCP/IPv4) -> Properties

\* *Changing the IP address of the host computer may require administrative rights.*

The IP address of the computer can quickly be found using Windows Command Prompt and the command "ipconfig." Remember that this will show all available network connections, including WIFI and, if applicable, multiple Ethernet ports.

Based on the examples above, the host computer can be configured to communicate with the default shipped IP address of the ENCL.

In situations where the IP address of the host computer cannot be altered, or if the ENCL must be integrated into an preexisting network, the ENCL's address must be changed to establish an Ethernet connection. The ENCL's IP address is set with the **IPADD** variable under the bootloader group (**LIST IP**). This can be changed through an existing Ethernet connection or via serial connection.

If an existing Ethernet connection can be established (by changing the host computer's IP address, using an alternate computer, or by some other means), it is the preferred method for changing the IP address of the ENCL. If Ethernet communication is not possible, a serial connection must be

established with the ENCL following the guidelines in the “Serial Communications” section.

If the **IPADD** variable is changed either through an Ethernet connection or a serial connection, the new address will not be effective until a **SAVEIP** command has been issued and the power is cycled. For more information on changing the IPADD variable, see the “Changing the IP Address” procedure.

### **CLIENT/HOST OPTIONS**

Once the module has been connected and the IP address has been configured, communications can be established with the ENCL module. Communications can be made through several software packages including:

- TCP/IP
- UDP
- PC - ScanTel
- PC - LabVIEW Configuration Utility (Scanivalve PN: 155384-01)
- PC - LabVIEW Development Kit (Scanivalve PN: 155385-01)
- PC - Windows HyperTerminal

#### **PC - TCP/IP**

The user may write their own TCP/IP interface using the software specification portion of this manual. This interface could allow the user to:

- Issue commands to any or all ENCL modules on the network.
- Display returned information from the ENCL module(s).
- Write returned information to the client/host in TCP/IP format.
- Determine the addresses of ENCL module(s) on the network.

#### **PC - UDP**

The user may write their own UDP interface using the software specification portion of this manual. This interface should allow the user to:

- Display returned information or scan data from the ENCL module(s).
- Write returned information or scan data to the client/host in UDP format (no handshaking).
- Determine the addresses of ENCL module(s) on the network.

#### **PC - SCANTEL**

ScanTel is a free communications utility designed by Scanivalve to communicate with Scanivalve products including ENCL modules. It is a text based, command line program that allows users to connect to a single ENCL module,

modify the configuration variables, and collect data using both TCP and UDP protocol. ScanTel is often the go-to choice for troubleshooting any Scanivalve module. ScanTel can be downloaded from [www.scanivalve.com](http://www.scanivalve.com).

#### **PC - LABVIEW CONFIGURATION UTILITY**

The Scanivalve LabVIEW Configuration Utility is software package that offers a very intuitive and simple way to connect to and modify all of the DSAENCL4000's configuration variables. It also allows the user the ability to upload a configuration file and scan and collect data. The scanning and data collection is limited to 5Hz due to the graphic nature of the program. The LabVIEW Configuration Utility is based on a LabVIEW 2009 runtime which is include with the installation disk.

#### **PC - LABVIEW DEVELOPMENT KIT**

The Scanivalve LabVIEW Development Kit is for users desiring to customize a LabVIEW driver for DSAENCL4000. The Development Kit is compatible with LabVIEW 8.2, 8.6 and 2009. The LabVIEW Configuration Utility is included with the Development Kit.

#### **PC - HYPERTERMINAL**

HyperTerminal is a Windows program included as part of Windows 2000, XP, and Vista Operating Systems. It is a text based, command line program. This program permits a users to connect to a single ENCL module, modify the configuration variables, format the internal memory, or can be used troubleshooting. HyperTerminal provides a means for both Serial RS-232 and Ethernet connections.

Alternate terminal emulators, such as PuTTY, can be downloaded for free from various sources online if HyperTerminal is not available.

## **SCANNING**

Once the ENCL module has been installed, powered on and allowed to thermally stabilize, data can be collected. There are several configuration variables that control how the ENCL module samples data pressure and how the data is output. Most of the configurations can be found under groups (LIST) S, I, C, and SG.

### **SCAN RATE**

The scan rate is controlled by two variables: **PERIOD** and **AVG1**. Rate is expressed in Hertz (Hz), which can be described as samples per channel per second, or more simply, frames per second.

The **PERIOD** variable is the inter-channel delay expressed in microseconds. This is the delay between samples taken at each channel (Sample channel 1, wait PERIOD, sample channel 2, wait PERIOD, etc). Pressure is sampled from sensor 1 to 64 (if 64 channels are available) and then the process will repeat based on the AVG setting.

The **AVG1** variable is the amount of internal averaging the ENCL will perform before sending out the pressure data for all channels. If **AVG** is set to 1, each sensor will be sampled once and then output to the network. If average is set to 5, the ENCL will sample each sensor 5 times (channel 1 to 64, then repeating 5 times to derive the 5 samples), average the value, and output the averaged pressure data (per channel).

Data rate is determined by the equation:

$$\text{Data Rate} = \frac{1}{(\text{Period}) \times (\text{Number of Channels}) \times (\text{AVG})}$$

Where: Period is expressed in seconds, and number of channels is always 64.

Example: If **PERIOD** is set to 125 and **AVG** is set to 25, the ENCL will scan and output data at 5Hz.

### **SCAN DURATION**

The length of the scan, or number of frames output per scan, is controlled by the variable: **FPS**. A frame of data typically consists of a frame number, time stamp, and one averaged pressure sample for each sensor in each DSA3016 scanned (or configured).

Example: If frames per second is set to 100, and the scan rate is set to 10Hz, the ENCL will output 100 frames of data at 10Hz. This scan will last 10 seconds and only 100 frames of data will be output. The scan will end when 100 frames are output.

Example: If frames per second is set to 0, and rate is set to 5Hz, the ENCL will output data at 5Hz indefinitely. The scan must be stopped manually by the user.

### **SCAN DATA FORMAT**

The data output for ASCII data collection is controlled by the variable: **FORMAT**. Format only applies to ASCII data collection, and will not affect binary data collection (**BIN == 0**).

Example: If format is set to 0, the ENCL will output the scan data in a scrolling format.

### **SCAN DATA UNITS**

The pressure and temperature unit values output in each frame of data are controlled by the variable: **UNITSCAN**. The ENCL supports a number of pressure engineering units including PSI, Pascals, Bar, and more. Temperature is limited to degrees Celsius.

Example: If units is set to PSI, the pressure values for each channel will be output in PSI engineering units, and the temperature for each channel will be in degrees Celsius.

*Note: in order to enable Engineering Unit output, EU under LIST C must be set to 1. If EU is 0, all data output will be in RAW format (analog-to-digital counts).*

### **STARTING A SCAN**

Once the ENCL has been configured for scanning, the ENCL will start sampling and outputting data after the **SCAN** command is issued to the ENCL module. The ENCL will then enter **SCAN** mode and will scan and output data continuously at the configured rate until the frames per scan (**FPS**) term is met or until the user has manually stopped the scan. Once the scan has been completed or terminated, the ENCL will return to **READY** mode and will be ready for the next command. This scenario is an example of a free-run, internal rate scan (**ADTRIG 0**). Data will be output from the ENCL module over the Ethernet connection and can be collected in the ASCII format.

There are several ways that the ENCL can scan and collect data. These options include:

- Internal rate, software scan triggered
- External rate, hardware frame triggering
- External rate, software frame triggering
- Internal rate, PTP time triggered

There are several ways that the ENCL can output scan data. These options include:

- ASCII data via TCP or FTP
- Binary data via TCP, UDP, or FTP



These options makes the ENCL an extremely versatile and configurable unit. All different scanning and data output methods will be described in this manual. For a quick reference chart for configuration, please see the “DSAECNL4000 Data Selection Chart” or Section 5: Software.

**SCANNING WITH AN EXTERNAL TRIGGER**

The DSAENCL4000 can be configured to scan with an external hardware or software trigger. This provides a simple means of synchronizing the data collection between multiple ENCL units or legacy Scanivalve products when IEEE-1588 PTP infrastructure is not in place. It also provides a means of synchronizing ENCL scanners with other, third-party equipment that may not be IEEE-1588 PTP compatible.

The external hardware trigger voltage (for frame triggering only) is input through pins A & B of the Digital Input PT02A connector. The ENCL accepts a trigger voltage that is between +4.5 and +15Vdc at 6.5mA. A wiring diagram for the digital input connector can be found in Section 4: Hardware.

ENCL4000 has several options for external triggering which is controlled by the variable: **ADTRIG** or **SCANTRIG**. The external trigger can be use in one of three ways:

1. Hardware Frame Trigger
2. Software Frame Trigger
3. Hardware Scan Trigger (not supported)

Options 1 & 2: the “Frame Trigger” options allow an external trigger to release a single frame of data per pulse sensed by the ENCL. This means for each trigger pulse (or software command) the ENCL will return a single frame of data. The rate of which the data is output is based on this external pulse rate.

For optimal external frame triggering, the internal scan rate of the ENCL should be set ≥25% higher than the external trigger rate. If a hardware trigger is being used, it must adhere to the ENCL’s trigger voltage requirement. A duty cycle of 50% is recommended, and the “low” voltage must be as close to 0Vdc as possible.

The software frame trigger is a command sent to the ENCL that will release a one frame of data per command received, similar to external hardware triggering. The trigger can be one of two commands; either a **TRIG** command or a <tab> character (9 Hex or Control I).

**SETTING UP AN EXTERNAL FRAME TRIGGER**

To configure the DSAENCL4000 to scan with an external

frame trigger (hardware or software):

1. Set the variable **ADTRIG** to 1 and **SCANTRIG** to 0
2. Set the scan rate (**PERIOD** and **AVG** variables) to a rate that is approximately 25% or faster than the intended external trigger rate
3. Set the ENCL into “scan” mode by sending the command: **SCAN**
4. Supply a trigger; either hardware trigger pulse or a software trigger. For each trigger pulse, the ENCL will output a single frame of data to the configured destination

**Option 3 (NOT SUPPORTED):** the “Hardware Scan Trigger” option allows for a SCAN to be initiated using an external voltage. When the ENCL senses that the trigger input level is “high” (5Vdc≤voltage≤15Vdc), the ENCL will enter scan mode where it will scan and continuously collect data based on its set internal rate. The ENCL will continue to scan at this rate until any of the following conditions are met:

- The trigger input level is switched to “low” (<5Vdc)
- The FPS variable is met (frames output = FPS)
- The scan is manually stopped by the user (software command or powering off the unit)

**Setting up an External Scan Trigger**

To configure the DSAENCL4000 to scan with an external scan trigger:

1. Set the variable **SCANTRIG** to 1 and **ADTRIG** to 0
2. Set the **RATE** variable to the desired data collection rate
3. Supply a “high” voltage (5Vdc<voltage<15Vdc). The ENCL will collect and output data at the defined rate until the trigger input voltage is lowered below the 5Vdc trigger threshold level.

**SCAN DATA OUTPUT METHODS**

**ASCII TCP SCAN DATA TRANSFER**

The default method of ASCII data collection and transfer is configured using the default Telnet server (port 23) using a TCP client. Programs like ScanTel, HyperTerminal, or PuTTY can be used to display and collect the ASCII data to the screen or to a file. If binary data output is not enabled, and the **SCAN** command is sent to the Telnet port, the ENCL will return data to the host from where the command was sent.

ASCII data can be formatted using the **FORMAT** variable under **LIST I**. Two formats available are:

- Unformatted, column based (scrolling)
- Formatted, VT100 terminal style (updating)

Data output follows the specified ASCII packet structure listed in Section 5: Software.

**BINARY TCP SCAN DATA TRANSFER**

The DSAENCL4000 can output binary scan data via TCP. The structure of the binary packet sent from the binary server is expressed in Section 5: Software.

Enabling TCP binary data transfers requires **BIN** to be set to a non-zero number and **BINADDR** to be set to 0 0.0.0.0. When a SCAN is executed, the binary data is returned over TCP port 23 to the host from where the command was issued.

**BINARY UDP SCAN DATA TRANSFER**

The DSAENCL4000 can transfer scan data using UDP protocol to an applicable UDP client. The user may set up any suitable UDP client for this operation. Data output follows the specified packet structure listed in Section 5: Software. Enabling UDP binary data transfers requires **BIN** to be set to a non-zero number and **BINADDR** to be set to a valid, non-zero port and IP address.

UDP output supports a multicast address following the standard UDP multicast address group, using a UDP address of 224.0.0.0 through 239.255.255.255 and any valid port.

**FTP SCAN DATA TRANSFER**

When the variable: **ENNAS** is set to 1 or 2, all ASCII or BINARY data are output via FTP protocol. Binary files will have the extension: .DAT. ASCII files will have the extension: .TXT.

The setting of ENNAS will determine the construction of the file name.

When ENNAS is set to 1, a sequence number is used to construct the file name.

For Binary (BIN = 1), the file name will be the file name prefix as set by the variable: FILENAS and a sequence number set by the software. The format is:  
<file name prefix>\_xxxx.DAT Where xxxx is a number from 0000 to 9999

For ASCII (BIN = 0), the file name will be the file name prefix as set by the variable: FILENAS and a sequence number set by the software. The format is:  
<file name prefix>\_xxxx.TXT Where xxxx is a number from 0000 to 9999

The sequence number is maintained in the DSAENCL4000 and saved to a file named: SSN,CFG. The save to SSN.CFG is automatic and not part of the SAVE command group. This file is maintained on the flash memory. If this file is not found the sequence will start at 0000.

When ENNAS is set to 2, the file name will be the file name prefix set by the variable FILENAS and the time and date derived from the NTP server, as long as a NTP time server exists.

**IEEE1588v2 PRECISION TIME PROTOCOL**

*NOTE: PTP is only available in firmware version 5.25 and higher. While these firmware versions are backwards compatible, some ENCL hardware may not support PTP. You can verify this by uploading the latest firmware version and issuing a GETTIME command a few times after the boot process. If the time starts at 1970/1/1 or 2015/1/1 and increments at a believable speed, then the hardware is PTP compatible. If the time is a non-believable combination of numbers or does not change properly, then it will require a hardware upgrade.*

*NOTE: The scan rate in the DSAENCL is limited to 312.5Hz or PERIOD 50 when using PTP.*

The DSAENCL4000 is compliant with IEEE1588v2 Precision Time Protocol (PTP). The ENCL's PTP engine can be configured as follows:

- Disabled
- Enabled as a PTP slave device
- Enabled as a PTP master device

When configured as a PTP slave device, the ENCL will listen for PTPv2 packets being multicasted on the network. This allows for the ENCL's internal time and date to be set and synchronized when a PTP Grandmaster is active on the same network. This synchronization will also adjust the internal scan rate of the module to pace with the PTP Grandmaster time.

When the DSAENCL4000 is configured as a PTP master device, the ENCL will multicast PTPv2 packets over the network, similar to a PTP Grandmaster. The ENCL will use its internal time and date when multicasting these packets for synchronization. The ENCL configured as a PTP master allows other PTP enabled Scanivalve devices to be synchronized using the internal time and date of the 'master' ENCL device. This synchronization on 'slave' devices will adjust the internal scan rate of the 'slaves' to pace with the PTP Master. *Note: Only one PTP Grandmaster or PTP master can be present on a network at any given time.*

When the ENCL's PTP engine is disabled or enabled as a PTP master, the ENCL's time and date can be manually set using the **GETTIME** command.

Other PTP related commands, including PTP statistical information, debug output, and setting the UTC offset, can

be referenced in the PTP Commands section under Section 5: Software.

**PTP TRIGGERED SCAN**

The IEEE1588 protocol allows DSAENCL4000 units to start scanning at a preset time and date while keeping their data samples time synchronized. This allows a user to synchronize the scan start time across multiple units. A scan start time and date in the future can be configured in the DSAENCL4000 using the Scan Start Date (SSD) and Scan Start Time (SST) variables. After a **SCAN** command is issued, the ENCL will enter scan mode but will not output data. Once the **SST** and **SSD** time has been met (based on the internal time of the ENCL), the time will trigger the ENCL to start releasing frames of data at the set internal rate. If **SST** and **SSD** are set for a time in the past (based on the internal time of the ENCL), a **SCAN** command will execute a scan and the ENCL will release data immediately.

The following table describes a start scan time with two DSAENCL4000 units when setting SSD and SST for a time in the future.

| Two (2) DSAENCL4000s configured with:<br>SST = 12:00:00, SSD = 2021/2/10, RATE = 1Hz |                        |                |                |                |                                 |                                 |
|--|------------------------|----------------|----------------|----------------|---------------------------------|---------------------------------|
| 1588 Date (hh:mm:ss)   | 1588 Time (YYYY/MM/DD) | Event          | ENCL 1 Frame # | ENCL 2 Frame # | ENCL 1 PTP Time Stamp (seconds) | ENCL 2 PTP Time Stamp (seconds) |
| 12:59:55   | 2021/2/10              | SCAN to ENCL 1 |                |                |                                 |                                 |
| 12:59:56   | 2021/2/10              |                | 1              |                | 1612990796                      |                                 |
| 12:59:57   | 2021/2/10              | SCAN to ENCL 2 | 2              |                | 1612990797                      |                                 |
| 12:59:58   | 2021/2/10              |                | 3              | 1              | 1612990798                      | 1612990798                      |
| 12:59:59   | 2021/2/10              |                | 4              | 2              | 1612990799                      | 1612990799                      |
| 1:00:00  | 2021/2/10              |                | 5              | 3              | 1612990800                      | 1612990800                      |

**ZERO OFFSET CALIBRATIONS**

The DSA3016’s internal calibration valve incorporates a zero offset correction feature (Quick Zero). This feature provides a simple and quick means to correct for the minor zero drift problems inherent to piezoresistive sensors. Even with pressure applied to the Px ports, the calibration valve can be configured into Calibrate mode, providing a pressure to be exposed to the positive and negative side of all transducers. At that point, with the sensor at its natural zero state, any offset can be read and recorded. This can then be factored into the engineering unit conversion and mathematically removed. Quick Zero calibrations can be performed in under 10 seconds.

Due to the nature of the piezoresistive sensors used in the DSA3016 modules, it is recommended that a quick zero calibration be performed at least daily. Performing a quick zero more often will not cause any problems and is highly encouraged. There are no issues using the quick zero calibration each time before data is collected. Keep in mind, if the temperature of the module changes more than 5°C, a fresh quick zero should be performed.

Zero offset corrections may become obsolete after several hours or after the module has changed temperatures. While the deltas can be saved through a power cycle, changes in the environment may cause the deltas to be obsolete.

**DIFFERENTIAL MODULES**

A quick zero offset calibration can be executed via the ENCL using the simple command: **CALZ**.

In order for the calibration valve to successfully switch and place the module into Calibrate mode, 90-120 psi clean, dry instrument grade control pressure air must be supplied to the CTL SUPPLY port on the ENCL. In the ENCL’s default

| Two (2) DSAENCL4000s configured with:<br>SST = 12:00:00, SSD = 2021/2/10, RATE = 1Hz |                        |                |                |                |                                 |                                 |
|--|------------------------|----------------|----------------|----------------|---------------------------------|---------------------------------|
| 1588 Date (hh:mm:ss)   | 1588 Time (YYYY/MM/DD) | Event          | ENCL 1 Frame # | ENCL 2 Frame # | ENCL 1 PTP Time Stamp (seconds) | ENCL 2 PTP Time Stamp (seconds) |
| 11:59:55   | 2021/2/10              | SCAN to ENCL 1 |                |                |                                 |                                 |
| 11:59:56   | 2021/2/10              |                |                |                |                                 |                                 |
| 11:59:57   | 2021/2/10              | SCAN to ENCL 2 |                |                |                                 |                                 |
| 11:59:58   | 2021/2/10              |                |                |                |                                 |                                 |
| 11:59:59   | 2021/2/10              |                |                |                |                                 |                                 |
| 12:00:00   | 2021/2/10              |                |                |                |                                 |                                 |
| 12:00:01   | 2021/2/10              |                | 1              | 1              | 1612987201                      | 1612987201                      |
| 12:00:02   | 2021/2/10              |                | 2              | 2              | 1612987202                      | 1612987202                      |
| 12:00:03   | 2021/2/10              |                | 3              | 3              | 1612987203                      | 1612987203                      |

The following table describes a start scan time with two DSAENCL4000 units when SSD and SST are a time in the past.

configuration, the rear solenoids will automatically switch the valve state of all plumbed DSA modules to Calibrate mode before the internal calibration is performed. If control pressure is not applied, the DSA modules will remain in Measurement (PX) mode when the CALZ is executed.

For typical zero offset correction operation, it is recommended that the CAL and REF ports on the module be plumbed to the same static location. For modules with a 15psi range or lower, the CAL and REF lines should be terminated in a dampened static environment using a static bottle or similar.

### **PURGING**

All DSA3016 modules incorporate an internal calibration valve. One of the configurations of this valve allows for an 'isolate-purge' feature. This permits the pressure measurement (Px) lines to be purged with pressures 50psi over the full scale module pressure up to 500psi during test. By isolating the pressure sensors from the purge pressure, even low pressure DSA3016 modules can be purged safely with high purge pressures. If the module range is greater than 500psi, it is not recommended to purge during test. It is not recommended to purge at greater than 100psi when purging to atmosphere.

The purge feature is useful when the DSA3016 module is used in applications where corrosive gasses, moisture, or contaminants may be present in the input lines.

In order to configure the DSA module for purge mode, 90-120psi of control pressure must be applied to the 'CTL1' 'CTL2' and 'PRGCTL' ports. Purge mode must be established in a set order to protect the internal sensors and calibration modules from damage. The DSAENCL4000 includes features that make purging simple and configurable, including integrated solenoids (for control pressure distribution), and software sequencing.

There are two methods for purging: automatic and manual. Automatic purge uses the PURGE command and variables under group D. If control pressures are routed through the ENCL's Control Source input, this is the optimal method for automatic purging. The procedure for automatic purging is as follows:

1. Apply 90-120 psi of control pressure to "Control Source" input
2. Send the command: **PURGE**. The purge sequence will start\*.
3. Apply a purge pressure to the PRG input on the DSA3016 module(s).
4. The purge will complete when either the DLYPG

reaches its value (in seconds) or a STOP command is issued.

5. The ENCL4000 will step back through the control pressure settings to return all modules to measurement mode.

For setting the purge sequence, see the PURGE command in "Section 5. Software."

*\* Purge sequence is defined as:*

*The valves are sequenced as set in DOUTPGSEQ (purge precondition) and DLYPGSEQ (precondition timeout). When DLYPGSEQ times out, the control valves are set according to DOUTPG (purge condition) and the DLYPG timer starts. A STOP command is issued before the DLYPG time has timed out will stop the purge time, otherwise the purge configuration will continue until DLYPG times out. The control valves are then immediately set to the DOUTPGSEQ condition and the DLYPGSEQ timer starts. When this timer times out, the enclosure exits PURGE mode, returns modules back to measurement mode, and waits for another command.*

For a manual purge on DSA3016 modules:

1. Apply 90-120 psi of control pressure to 'CTL1' and 'CTL2' ports.
2. Apply 90-120 psi of control pressure to the 'PRGCTL' port.
3. Apply the purge pressure to the 'PRG' port.

Re-configuring after a purge:

1. Shut off the purge pressure feeding the 'PRG' port. Make sure to allow sufficient time for the input lines to stabilize. The specific time required will depend upon the physical layout and characteristics of the system.
2. Remove 90-120 psi control pressure from the 'PRGCTL' port.
3. Remove the 90-120 psi control pressure from the 'CTL1 and 'CTL2' ports.



CAUTION! Failing to follow the above procedure while entering or exiting the purge mode could allow the sensor to see the high purge pressure and could seriously damage the DSA module.

If the manual purge is performed using the DSAENCL4000 and control pressure is supplied to the Control Source, the DOUT command can be used to manually enable the solenoids to direct pressure to CTL1, CTL2 and PRGCTL. For information on the DOUT command, see "Section 5. Software."

# SECTION 4: HARDWARE

## PNEUMATIC CONNECTIONS

The DSA3016 module has several different pneumatic connections. There are two basic types of pneumatic connections on each module: pressure measurement connections (Px) and configuration pressure connections (Control). The pressure measurement ports are the 16 ports labeled 1-16 (or 1 through 8 and (-)1 through (-)8 on differential pressure modules) below the rear panel of the module or on the front for Front Access modules. These ports are connected to the pressure transducers within the module. Also included in the pressure measurement ports are the CAL and REF ports. Dual range modules will have CAL A and CAL B, and REF A and REF B ports (also referred to as CAL High/Low and REF High/Low). These ports are used for applying known pressures during calibration, and reference pressures during normal data collection and calibrations. It is very important that all pressure measurement connections are completely leak tight. Any minor leak will cause an error in the measured pressure.

The control source is a single connection on the ENCL rear panel. This is a 1/4" Swagelok® compression fitting. This control source is controlled by internal solenoids and provides pressures to Control1, Control2, and Purge Control. All air supplied to the control ports needs to be instrument grade, clean dry air. Nitrogen is a very good alternative for when instrument grade air is not available.

DSA3016s configured as Front Access modules can be configured with 1/8" compression fittings. The rear back blocks for these modules will be the same. Rear access modules will use 1/16" bulged, stainless steel tubulations or 1/16" compression fittings on the rear back block.

### MAKING 1/16" TUBULATION CONNECTIONS

Begin by applying a small amount of Scanivalve brown pipe sealant (PN: SLNT-2) to the outside of the tubulation. Carefully slide the tubing over the outside of the stainless steel tubulation (Scanivalve's tubing push-on tool TPOTL-XXX makes this job easy). Ensure that the end of the Urethane, Nylon or Teflon tubing extends at least 1/16" beyond the bulge on the tubulation. Finally, slide the helical spring clamp over the outside of the tubing, ensuring that the spring clamp ends up over the bulge. Helical spring clamps are required for all pressure ports that will see over 100psi and they are highly recommended for all tubulation style pneumatic connections. When using Teflon tubing, spring clamps are required on all connections no matter what the measurement pressure is.

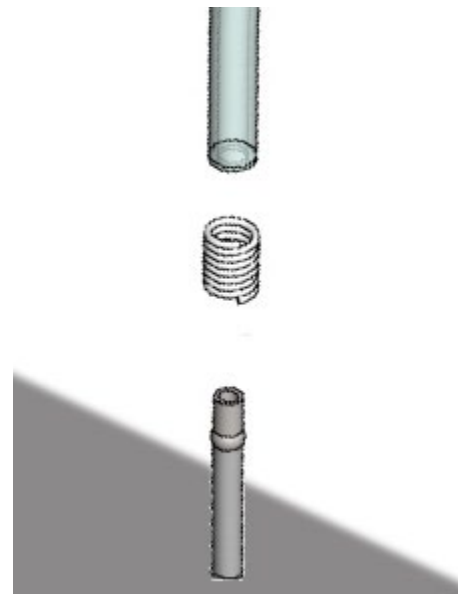

**FIGURE 4.1- TUBULATION PNEUMATIC CONNECTIONS**

### MAKING SWAGELOK® COMPRESSION CONNECTIONS

Each Swagelok® compression fitting includes 4 parts: the nut, the front ferrule, the back ferrule and the body. Squarely cut the end of the nylon or Teflon tubing being used. Slide the nut and both ferrules up on the tubing, then insert it all of the way into the Swagelok® body. Tighten the nut finger tight, to the point where the tube cannot be removed by hand. Finally, with a wrench tighten the nut 3/4 to 1 1/4 more turns. There is no need to tighten the nut any more than this.

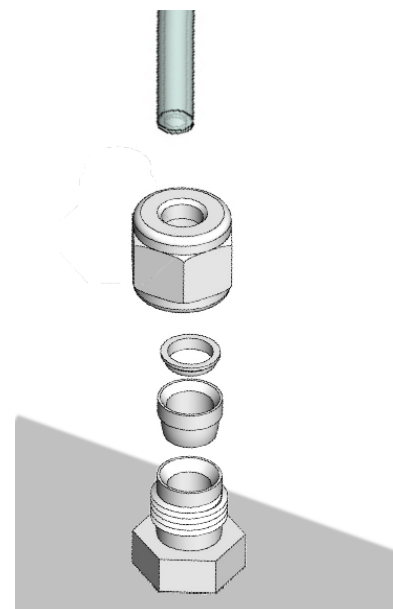

**FIGURE 4.2- SWAGELOK® COMPRESSION CONNECTIONS**

**PRESSURE MEASUREMENT(Px) PORTS**

Each DSA3016 module has 16 pressure measurement ports, or Px ports. They will be labeled 1-16, or for 8 DPx units  $\pm$  1-8. Each of these ports are connected to a discrete pressure transducer. If any Px ports are not being used, it is recommended that they be plugged to prevent dust or debris from clogging the port or contaminating the internal calibration valve.

**CALIBRATION (CAL) PORT**

For each pressure range the DSA3016 module has, there will be a 'CAL' port. Most modules will only have one 'CAL' port, but dual range modules will have two (labeled 'CAL L' and 'CAL H'). The 'CAL' port provides a means to apply a known calibration pressure to a single port and have it manifolded to all of the transducers of the related pressure range. During normal operations, with no control pressures applied this port is internally blocked off. Any pressure applied to the 'CAL' port will not reach the transducers unless the internal calibration valve has been configured to direct the calibration pressure to the transducers. For low pressure modules (below 5 psi) the 'CAL' port should be routed to a known, stable static location when not being used to apply calibration pressures. This ensures that when a zero offset calibration (CALZ) is performed no unwanted offsets are introduced.

**REFERENCE (REF) PORT**

For each pressure range the DSA3016 module has, there will be a 'REF' port. Most modules will only have one 'REF' port, but dual range modules will have two (labeled 'REF L' and 'REF H'). On differential pressure modules, the 'REF' port is labeled 'CAL NEG.' The 'REF' port ties into a manifold that connects the back side (or negative side) of all transducers of the same pressure range together. During most applications, the 'REF' port of low pressure modules (below 5 psi) should be routed to a known, stable static location. This ensures that when a zero offset calibration (CALZ) is performed no unwanted offsets are introduced. During a calibration, positive pressures will be applied through the 'REF' port to perform the negative portion of the calibration.

**CONTROL 1 (CTL1) PORT (DOUT6)**

Control 1 (CTL1) is the 'isolation' control. By sending the command : DOUT6; a solenoid will change state and 90-120psi will flow to the CTL1 port which closes a normally open (flow) valve and configures the internal calibration valves into isolate mode, meaning that pressures applied to the pressure measurement ports (Px 1-16) will not reach the transducers. CTL1 controls both internal calibration valves simultaneously, they cannot be operated separately. Ensure that any control air applied to CTL1 is clean, dry instrument grade air or nitrogen.

**CONTROL 2 (CTL2) PORT (DOUT 7)**

Control 2 (CTL2) is the 'calibration' control. By sending the command: DOUT7; a solenoid will change state and 90-120 psi will flow to the CTL2 port opening a normally closed (no flow) valve and configures the internal calibration valve into calibration mode, meaning that pressures applied to the 'CAL' port(s) will reach the transducers. CTL2 controls both internal calibration valves simultaneously, they cannot be operated separately. Ensure that any control air applied to CTL2 is clean, dry instrument grade air or nitrogen.

**PURGE CONTROL (PRGCTL) PORT (DOUT 8)**

For applications where the pressure measurement ports (Px ports) may become plugged or contaminated, the DSA3016 module is equipped with a purge function. By sending the command: DOUT8; 90-120psi will flow to the purge control (PRGCTL) port opening a normally closed (no flow) valve. While using the control 1 port (CTL1) and control 2 port (CTL2) in addition to the purge control port (PRGCTL), this places the internal calibration valve into purge mode by opening the purge supply to the Px ports and isolating the sensors from the purge pressure. Like the other control pressures, ensure that any control air applied is clean, dry instrument grade air or nitrogen.



CAUTION! Applying PRGCTL after or without CTL1 applied can allow sensors to see the purge pressure potentially causing serious damage to the module.

**PURGE SUPPLY (PRG) PORT**

The purge supply (PRG) port is the input for the pressure that will be used to purge the pressure measurement (Px) lines. The supplied purge pressure can be up to 750 psi, and must always be clean, dry instrument grade air or nitrogen.

**DSA CALIBRATION VALVE**

Each DSA3016 module has two internal calibration valves. The calibration valves can be configured using the three control pressure inputs on the DSA3016 module (CTL1, CTL2 and CLTPRG). The two calibration valves cannot be operated independently. The calibration valves are configured such that no control pressures are required for normal measurement operations. The following tables outline the required control pressure input for each calibration valve configuration.

Standard DSA3016 Calibration Valve configurations:

| MODE      | CTL1       | CTL2       | PRGCTL     |
|-----------|------------|------------|------------|
| OPERATE   |            |            |            |
| CALIBRATE | 90-120 psi | 90-120 psi |            |
| PURGE     | 90-120 psi | 90-120 psi | 90-120 psi |
| ISOLATE   | 90-120 psi |            |            |

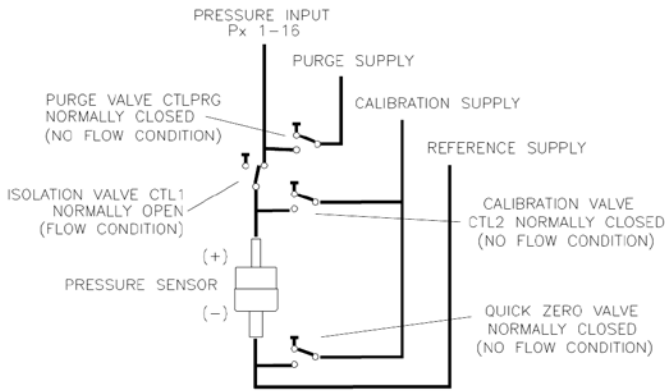

FIGURE 4.3 - STANDARD VALVE LOGIC

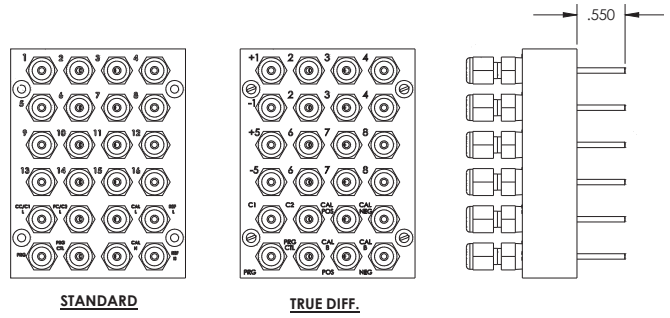

FIGURE 4.6- SWAGELOK® BACK BLOCK CONFIGURATION

**DSA3016 BACK BLOCK CONFIGURATIONS**

The DSAENCL4000/DSA3016 come standard with multiple back block configurations. Configurations consist of a Universal block configuration, a standard configuration, and a Swagelok® fitting option.

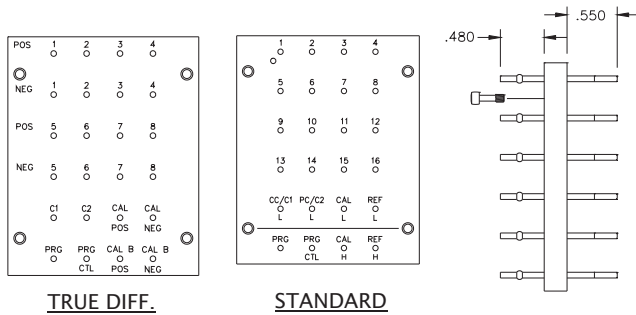

FIGURE 4.4 - STANDARD BACK BLOCK CONFIGURATION

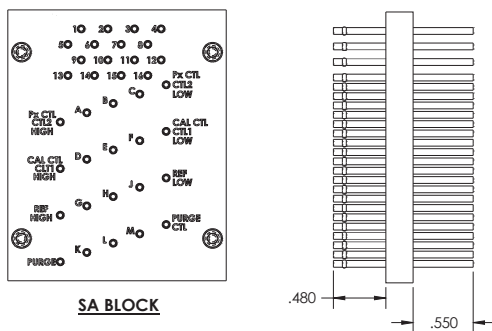

FIGURE 4.5 - UNIVERSAL BACK BLOCK CONFIGURATION

**ECNL4000 ELECTRICAL CONNECTIONS**

**ETHERNET CONNECTION**

A DSAENCL4000 has one Ethernet 100Base-T with MDIX auto-crossing connection. The Ethernet subsystem supports IEEE 802.3 Ethernet standards for 10BaseT and 100BaseT. The subsystem will auto-negotiate the data rate. The Ethernet connection is a RJ45 jack.

The DSAENCL4000 will not support multiple Ethernet connections. If a second Ethernet connection is made to the DSAENCL4000, the first connection will be dropped and the new connection will be established.

“Figure 4.7 - Ethernet RJ45 Plug and Jack” shows the RJ45 jack, plug and wiring. The Ethernet cable used should not be longer than 328 feet (100 meters).

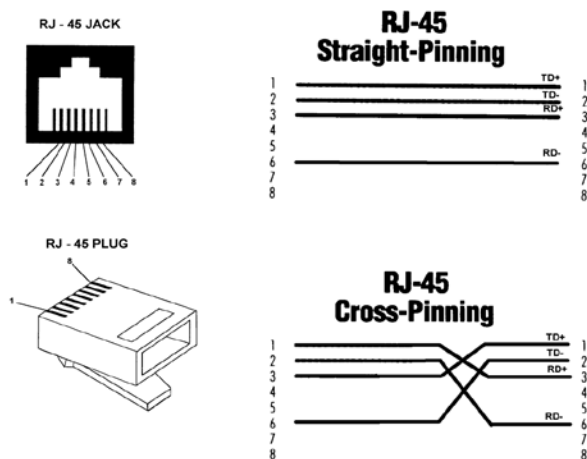

**FIGURE 4.7 - ETHERNET RJ45 PLUG AND JACK**

**SERIAL CONNECTIONS**

Each DSAENCL4000 has two Serial connections; COM1 and COM2.

COM1 may only be used for external Scanivalve device communications. Scanivalve device communications includes communication with a SPC3000 Calibrator or another Scanivalve Auxiliary Serial Device (legacy devices).

COM2 is configured for debug operation, Device Communications or Host Communications. This also includes finding or changing the IP address of the ENCL.

The connections conform to the RS232C standard. The COM ports are configure:

- 9600 BAUD
- 8 data bits
- 1 stop bit
- No parity
- No Flow Control

The serial connector wiring is shown in Figure 3.2 (typical used for COM1) and Figure 3.3 (typically used for COM2 or ENCL to Computer). For more information on the serial communication setup, please refer to the Scanivalve DSP Boot Loader Section in this manual.

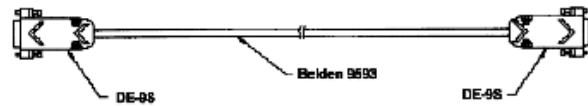

**FIGURE 4.8 - RS232C - DTE TO DCE**

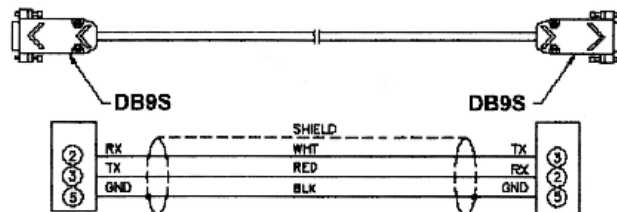

**FIGURE 4.9 - RS232C - DTE TO DTE**

**DIGITAL I/O CONNECTIONS**

Each DSAENCL4000 has a digital input and a digital output connector. A maximum of five digital inputs and five digital outputs may be configured. Configuration information may be found in the Software Section of this manual.

Digital Input 1 is reserved for the Hardware Trigger Input for Frame triggering. Digital inputs are edge triggered. The input pulse should have a minimum voltage of 4.5 Vdc and a maximum voltage of 15 Vdc. *NOTE: Digital inputs 2 - 5 are currently disabled in the DSAENCL4000 firmware.*

The digital outputs are powered directly by the ENCL power supply (up to 28Vdc). It is recommended that the user supply be capable of providing sufficient current drive for the DSAENCL4000 and the digital outputs. Each digital output is limited to 500 mA.

The digital input connector is a Bendix PT02A-12-10P. The



mating connector (cable connector) is a Bendix PT06A-12-10S.

The digital output connector is a Bendix PT02A-12-10S. The mating connector (cable connector) is a Bendix PT06A-12-10P.

“Figure 4.10 - Digital Input Wiring” shows the wiring of the digital input connector. “Figure 4.11 - Digital Output Wiring” shows the wiring of the digital output connector.

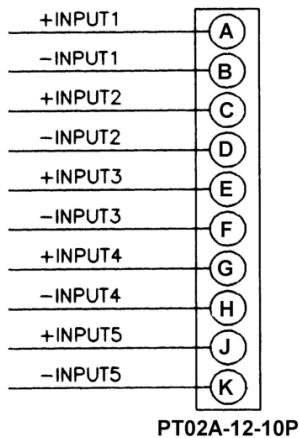

FIGURE 4.10 - DIGITAL INPUT WIRING

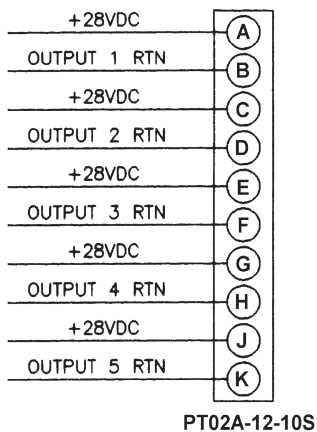

FIGURE 4.11 - DIGITAL OUTPUT WIRING

**DSA3016 ELECTRICAL CONNECTIONS**

Each DSAENCL4000 is designed to accept inputs from up to eight(8) DSA3016, ZOC16TC, DSA16EIM, or ZOC16EIM modules or any combination. Each input module may have up to 16 inputs. In order to get the full benefit of the DSA Technology, ZOC16TC modules must have an RTD installed so the DSAENCL4000 can measure the temperature of the module. DSA16EIM and ZOC16EIM modules do not require

an RTD. No other special wiring is required.

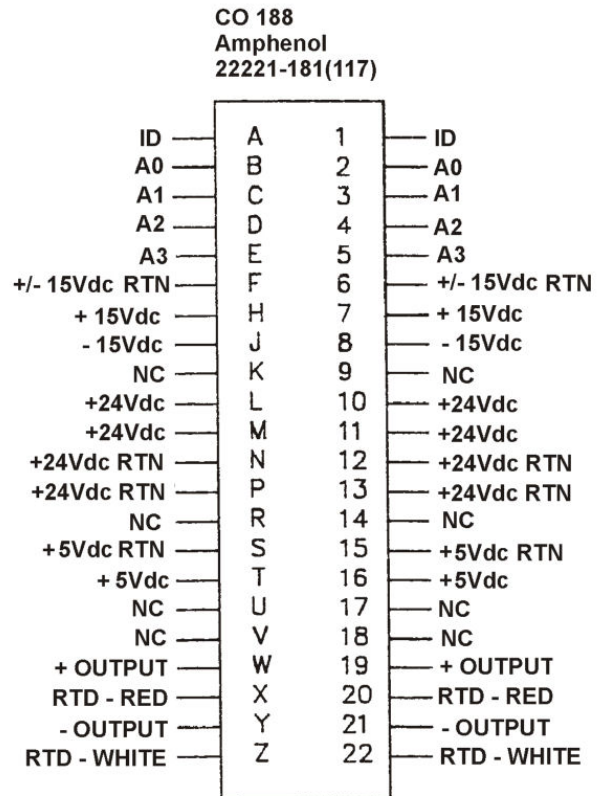

FIGURE 3.6 - DSAENCL4000 BACKPLANE PINOUTS

**DSA3016 ID CHIP AND ID SWITCH**

All DSA3016 modules manufactured after September 1, 2004 have an ID chip and enabling switch installed. The ID chip is programmed with information describing the module. This feature will make these modules fully compatible with DSAENCL4000 series enclosures. The ID chip outputs information on the same pins used as the Strobe Line in HyScan systems. The ID Enable switch has two positions, I and S. When the switch is in the I position, the ID chip data will be output to an Enclosure on pins A and 1 on the backplane connector. When the switch is set to the S position, pins A and 1 will be used as a Strobe Line to enable Ring Mode addressing for HyScan 2000 Systems.

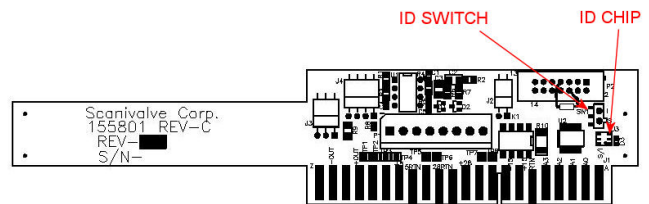

FIGURE 3.7 - DSA3016 ID CHIP & SWITCH LOCATION

This page is intentionally left blank

# SECTION 5: SOFTWARE

---

## OVERVIEW

The DSAENCL4000 is a single user network server that supports connections from a Telnet Client. The operation of a ENCL module is controlled by sending commands to selected modules by network addressing via the network. The ENCL returns data or information over the network to the requesting client/host.

The DSAENCL4000 also supports serial communication that can be used to set configuration variables, diagnostics and troubleshooting, or used when the ENCL's IP address is not known.

The section on ENCL Commands lists each command and explains its function.

## ENCL COMMANDS

The ENCL software must run as embedded software on the ENCL pressure scanner hardware. It performs the following general tasks:

1. Read and filter the raw A/D counts that represent pressure and temperature.
2. Convert the pressure A/D counts to user chosen pressure units.
3. Receive and execute commands from the Ethernet link.
4. Allow configurations to be saved through power down.
5. Output converted data, status, setup and calibration data over the Ethernet Link.
6. Set the ENCL Physical Ethernet Address (MAC Address).
7. Data transfer protocol to be TCP, UDP, or FTP.
8. Support the user in troubleshooting the ENCL hardware and system.

TCP/IP does not guarantee that packet boundaries will be maintained between a host and a ENCL module. Therefore, all commands from a host must be terminated properly with one of four options. The ENCL will detect and adjust to the termination option being used by a host.

The four options are:

- CR (ASCII 13)
- LF (ASCII 10)
- LF-CR (ASCII 10 - ASCII 13)
- CR-LF (ASCII 13 - ASCII 10)

When a ENCL module is not in "READY" mode, most commands are disabled or not accepted. Examples of when the ENCL module may not be in "READY" mode could be:

- During CALZ
- During SAVE
- While Scanning

The exceptions to this rule are the commands STOP, STATUS, TRIG, and PURGE.

The maximum string length for commands sent to the DSAENCL4000 is 79 characters. Any command received that is longer than 79 characters will be discarded and an error will be generated.

When a communications variable in the IP group are modified, such as IP, MAC, or Gateway, the configuration must be saved, and the DSAENCL4000 software must be restarted in order for the changes to take effect.

## **COMMAND FORMAT**

Each of the commands are explained with the following sections: command, syntax, arguments, description, and returns.

COMMAND lists the name of the command.

SYNTAX lists the format of the command. The following conventions are used:

**BP** - Boldface letters indicate command keywords and operators. Within the discussion of syntax, bold type indicates that the text must be entered exactly as shown.

*expression* - Words in italics indicate place holders for information you must supply, or information returned by the calibrator, such as a coefficient name or pressure data.

[/H] - Items in square brackets are optional.

, - Commas separate options, only one of the options may be used.

<CR> - Items in angle brackets are used for names of keys on a typical keyboard. The carriage-return key, sometimes marked as a bent arrow, Enter, or Return on the keyboard, is called <CR>.

Spaces, as used in the syntax, are entered as spaces.

DESCRIPTION describes the function of the command.

RETURNS lists the format of the information that the unit returns to the host.

A PROMPT (>) will be output when the DSAENCL4000 is ready to accept a command.

TCP/IP does not guarantee that packet boundaries will be maintained between a Host and a DSAENCL4000. Therefore, ALL commands from a Host MUST be terminated properly with one of two options using the NL configuration variable. The two options are:

CR-LF (ASCII 13 - ASCII 10) or CR (ASCII 13)

The maximum string length for commands send to the DSAENCL4000 is 79 characters. Any command received that is longer than 79 characters will be discarded and an error will be generated.

When a communications variable is modified (those in the LIST IP group), the DSAENCL4000 must be restarted, preferably with the REBOOT command, in order for the changes to take effect.

**COMMAND LIST**

**AUXILIARY COMMAND**

| Command     | Auxiliary Command   |
|-------------|---|
| Syntax      | AUXCMD <cmd> <CR>   |
| Arguments   | command Any valid string to auxiliary device connected to a serial port.  |
| Description | This command permits a host computer to send a command to a device connected to a ENCL. The variable: AUX, must be enabled for this command to be recognized.   |
| Returns     | <nl> -end of line   |
| Example     | If a user wanted to command a calibrator, SPC4000 or SPC3000, connected to the serial port to apply a pressure to the ENCL modules, the following command would be issued:<br>AUXCMD [a]GP 15 <CR><br>where a is the address of the calibrator.<br><br>The calibrator will output 15 psi.   |
| Notes       | When BIN is set to 1 and the BINADDR is set to a value other than zero, the data from the AUX or CAL commands are converted to a BINARY format and output over the UDP binary port specified in the BINADDR variable. The data format is:<br><ID byte> = 1 byte, the value will be 1 if the data is from a calibrator or 2 if the data is from an auxiliary unit.<br><Pressure> = 4 bytes of floating point binary pressure data. |

**A/D CALIBRATION (NON-TEMPERATURE COMPENSATED)**

| Command     | A/D CALIBRATION (NON-TEMPERATURE COMPENSATED)   |
|-------------|---|
| Syntax      | <b>A2DCAL</b> <module> <index> <voltage><CR>  |
| Arguments   | module - The A/D module being calibrated. 0 is the ENCL, 1 to 8 indicate pressure A/D's.<br>index - The Calibration point, 0 through 15<br>voltage - The applied calibration voltage  |
| Description | This command is used to produce the voltage correction table for a non-temperature compensated A/D. Although 16 points may be applied, a user may use as few as three points.   |
| Returns     | <nl><br><nl> - end of line.   |
| Example     | To calibrate a non-temperature compensated A/D module installed in position 1, apply a series of voltages. The entries may be as follows:<br><br>A2DCAL 1 0 0.0000<br>A2DCAL 1 1 0.5000<br>A2DCAL 1 2 1.0000<br>A2DCAL 1 3 1.5000<br>A2DCAL 1 4 2.0000<br>A2DCAL 1 5 2.5000 |
| Notes       | This command will only generate the correction table. It does not convert the table to a set of coefficients. Coefficients are generated by the A2DCALC command and written to the A/D module using the IDPWRITE command.   |
| Notes       | <b>This command is recommended for factory use only.</b>  |

***A/D CALIBRATION (TEMPERATURE COMPENSATED)***

|             |   |
|-------------|---|
| Command     | A/D CALIBRATION (TEMPERATURE COMPENSATED)   |
| Syntax      | <b>A2DTCAL</b> <module> <t index> <point index> <voltage><CR>   |
| Arguments   | module - The A/D module being calibrated. 0 is the Enclosure temperature A/D, 1 to 8 indicate pressure A/D's.<br>t index - The temperature index, 0 through 7<br>point index - The Calibration point, 0 through 15, for a t index<br>voltage - The applied calibration voltage        |
| Description | This command is used to produce the voltage correction table for a temperature compensated A/D. Although 16 points may be applied at each temperature index, a user may use as few as three points.   |
| Returns     | <nl> - end of line.   |
| Example     | To calibrate a temperature compensated A/D module installed in position 1, apply a series of voltages. The entries may be as follows:<br>A2DTCAL 1 1 0 0.0000<br>A2DTCAL 1 1 1 0.5000<br>A2DTCAL 1 1 2 1.0000<br>A2DTCAL 1 1 3 1.5000<br>A2DTCAL 1 1 4 2.0000<br>A2DTCAL 1 1 5 2.5000 |
| Notes       | This command will only generate the correction table. It does not convert the table to a set of coefficients. Coefficients are generated by the A2DTCALC command and written to the A/D module using the IDPWRITE command.  |
| Notes       | This command is not functional in Version 5.07 and lower. <b>This command is recommended for factory use only.</b>  |

***A/D COEFFICIENT CALCULATION (NON-TEMPERATURE COMPENSATED)***

|             |  |
|-------------|--|
| Command     | A/D COEFFICIENT CALCULATION (NON-TEMPERATURE COMPENSATED)  |
| Syntax      | <b>A2DCALC</b> <module> <number of points><CR>   |
| Arguments   | module - The A/D module being calibrated. 0 is the Enclosure A/D, 1 to 8 indicate pressure A/D's.<br>number of points - the number of points in the coefficient table  |
| Description | This command is used to calculate the voltage correction coefficients for a non-temperature compensated A/D. Three coefficients are generated: ADCC, ADCB, and ADCA. They will only be calculated by this command. IDPWRITE and IDPCONFIRM are used to write these coefficients to the ID chip   |
| Returns     | <mod> <ac> <bc> <cc><nl><br><br><mod> - The A/D module, 0 to 8, where 0 is the and 1 to 8 corresponds to the A/D modules<br><ac> - The A coefficient in the polynomial<br><bc> - The B coefficient in the polynomial<br><cc> - The C coefficient in the polynomial<br><nl> - end of line   |
| Example     | A series of voltages have been applied using the A2DCAL command. To generate the third order polynomial for the A/D correction for module 1, type: A2DCALC 1 6<br><br>The ENCL software will calculate the polynomial coefficients and return them. They will not be written to the ID chip until IDPWRITE and IDPCONFIRM commands have been executed. |
| Notes       | This command will only generate the correction coefficients. Coefficients are written to the A/D module ID chip using the IDPWRITE command.  |
| Notes       | <b>This command is recommended for factory use only.</b>   |

**A/D COEFFICIENT CALCULATION (TEMPERATURE COMPENSATED)**

|             |   |
|-------------|---|
| Command     | A2DTCALC (TEMPERATURE COMPENSATED)  |
| Syntax      | A2DTCALC <module> <number of temp planes> <number of points><CR>  |
| Arguments   | module - The A/D module being calibrated. 0 is the Enclosure A/D, 1 to 8 indicate pressure A/D's.<br>index - The Calibration point, 0 through 15<br>voltage - The applied calibration voltage   |
| Description | This command is used to produce the voltage correction coefficients for a temperature compensated A/D. Although 16 points may be applied, a user may use as few as three points.  |
| Returns     | <mod> <ac> <bc> <cc><nl><br><br><mod> - The A/D module, 0 to 8, where 0 is the and 1 to 8 corresponds to the A/D modules<br><ac> - The A coefficient in the polynomial<br><bc> - The B coefficient in the polynomial<br><cc> - The C coefficient in the polynomial<br><nl> - end of line  |
| Example     | A series of voltages have been applied using the A2DCAL command. To generate the third order polynomial for the A/D correction for module 1, type: A2DTCALC 1 6<br><br>The ENCL software will calculate the polynomial coefficients and return them. They will not be written to the ID chip until IDPWRITE and IDPCONFIRM commands have been executed. |
| Notes       | This command will only generate the correction coefficients. Coefficients are written to the A/D module ID chip using the IDPWRITE command.   |
| Notes       | This command is not functional in Version 5.07 and lower. <b>This command is recommended for factory use only.</b>  |

**BOOTLOADER VERSION**

|             |  |
|-------------|--|
| Command     | BOOTLOADER Version   |
| Syntax      | BLVER<CR>  |
| Arguments   | none   |
| Description | requests the version number of the bootloader installed in the DSAENCL4000.  |
| Returns     | BOOTLOADERVERSION: <version string> <nl>   |
| Example     | To determine the version of the DSAENCL4000.hex software in use type:<br>BLVER<CR><br>The ENCL will return:<br>BOOTLOADER VERSION: VER 2.02                      |
| Notes       | This command is only active in DSAENCL4000.hex version 5.07 and higher.<br>If the bootader version is 2.01 or lower, this command will not return a valid value. |

**CALIBRATE**

|           |   |
|-----------|---|
| Command   | CALIBRATE   |
| Syntax    | CAL <pressure> <channels> <CR>  |
| Arguments | <pressure> A real number that represents the calibration pressure for this point<br><channels> A combination of:<br>module-port for on channel; or:<br>module-port, module-port for multiple modules; or:<br>module-port...module-port for a range of modules.<br>Module is the physical location of the module in the system.<br>Port is a single pressure sample point within a module. |

|             |  |
|-------------|--|
| Command     | CALIBRATE  |
| Description | This command reads one averaged frame of pressure and temperature counts. The data returned from this command will be lost if it is not captured in a log file or by the host computer. NOTE: The ENCL does not control the calibration. It will only read the information when commanded.   |
| Returns     | INSERT <temp><channel><pressure><pressure counts> M<nl><br><temp>- the temperature plane<br><channel>- the channel in module-port notation<br><pressure>- the pressure in EU<br><pressure counts>- the A/D pressure counts(or bits)<br><nl>- end of line   |
| Example     | If a user wanted to calibrate a module installed in position 3 at 15 psi:<br>Apply the appropriate Control pressures for the module<br>Connect a pressure standard to the CAL input.<br>Enter the command:<br>CAL 15 3-1..3-16<CR><br>The ENCL will measure the counts for each channel and return the appropriate INSERT commands.  |
| Notes       | When BIN is set to 1 and the BINADDR is set to a value other than zero, the data from the AUX or CAL commands are converted to a BINARY format and output over the UDP binary port specified in the BINADDR variable. The data format is:<br><br><ID byte> 1 byte, the value will be 1 if the data are from a calibrator or 2 if the data are from an auxiliary unit.<br><br><pressure> 4 bytes of floating point binary pressure data |

**CALIBRATE INSERT**

|             |   |
|-------------|---|
| Command     | CALIBRATE INSERT  |
| Syntax      | CALINS <pressure> <channels> <CR>   |
| Arguments   | <pressure> A real number that represents the calibration pressure for this point.<br><channels> A combination of:<br>module-port for one channel; or<br>module-port, module-port for multiple modules; or<br>module-port...module-port for a range of modules.<br>Module is the physical location of the module in the system.<br>Port is a single pressure sample point within a module. |
| Description | This command reads one averaged frame of pressure and temperature counts and stores the information in memory in the INSERT format shown in the CALIBRATE Command.  |
| Returns     | <nl>- end of line   |
| Example     | If a user wanted to calibrate a module installed in position 3 at 15 psi:<br>Apply CTL1 and CTL2 Control pressures<br>Connect a pressure standard to the CAL input.<br>Enter the command:<br>CALINS 15 3-1..3-16<CR><br>The ENCL software will measure the counts for each channel and write the new master plane information into memory.  |
| Notes       | The ENCL does not control the calibration. It will only read the information when commanded.  |



**CALIBRATE ZERO**

|             |   |
|-------------|---|
| Command     | CALIBRATE ZERO  |
| Syntax      | CALZ<CR>  |
| Arguments   | None  |
| Description | Commands the ENCL to perform a zero calibration. This operation produces A/D count values for each pressure channel that is subtracted from the raw pressure counts before conversion to the engineering units. The data are stored in a Zero Array and a Delta Array. These values may be read by executing a ZERO or DELTA command. This command places the ENCL in the CALZ Mode until the command is completed or a STOP command is issued. CALZ requires approximately 15 seconds to complete.   |
| Returns     | <n>- end of line  |
| Example     | To update the current ZERO file and correct for any zero drift of the transducers:<br>Enter the command:<br>CALZ<br>The ENCL software will measure the zero counts for each channel and update the Zero and Delta Arrays. The ENCL software will write the information into the file, ZERO.CFG when a SAVE Command is executed.   |
| Notes       | General rules for use of a CALZ command<br><ol style="list-style-type: none"> <li>1. Power Up A CALZ should be executed after the ENCL and DSA3016 modules have stabilized.</li> <li>2. Power Cycle A CALZ should be executed if power is cycled, or if a REBOOT, or RESTART command is executed.</li> <li>3. REBOOT A CALZ should be executed after a REBOOT command.</li> <li>4. Module Swap A CALZ should be executed after a module position swap. If the module has reached stability before the swap, the CALZ may be executed immediately after a LIST SYS U command.</li> <li>5. Module Change A CALZ should be executed after a module change. The module should be allowed to stabilize before executing the CALZ command, but after a LIST SYS U command.</li> </ol> <p>The Zero and Delta Arrays are cleared when the ENCL is powered down or when a REBOOT command is executed. The data in the ZERO.cfg file is intended to be historical data. The Zero and Delta values are not reloaded at power up or restart because it is impossible to determine how long the power has been off. This also is designed to ensure that a new set of zeros is acquired if modules have been switched, or changed without a power cycle.</p> |

**CALIBRATOR COMMAND**

|             |   |
|-------------|---|
| Command     | CALIBRATOR COMMAND  |
| Syntax      | CALCMD <calibrator command> <CR>  |
| Arguments   | <calibrator command> -Any valid Calibrator Command- refer to the applicable Calibrator Software Manual for more information.  |
| Description | This command permits a host computer to send a command to one or more Serial Calibrators connected to a ENCL. The variable: CAL, must be enabled for this command to be recognized.   |
| Returns     | <n> -End of line  |
| Example     | If a user wanted to command a calibrator, SPC3000 or SPC4000, connected to the serial port to apply a pressure to the DSA3016 modules, the following command would be issued:<br>CALCMD [a]GP 15 <CR><br>where [a] is the address of the calibrator<br><br>The calibrator will output 15 psi. |
| Notes       | None  |



**CONTROL PRESSURE RESET**

|             |   |
|-------------|---|
| Command     | CONTROL PRESSURE RESET  |
| Syntax      | DOUTPU<CR>  |
| Arguments   | None  |
| Description | Resets the control pressures to the power up condition. This also will reset DOUTs that have been manually set. |
| Returns     | <nl> -end of line   |
| Example     | To reset the control pressures to the power up mode, Type:<br>DOUTPU<Enter>                                     |
| Notes       | None  |

**CREATE SENSOR PROFILE FILE**

|             |   |
|-------------|---|
| Command     | CREATE SENSOR PROFILE FILE  |
| Syntax      | CREATESPF <sensor serial number> <channel number> <CR>  |
| Arguments   | <sensor serial number> -the serial number of the replacement sensor<br><channel number> -the location of the new sensor in position-port format   |
| Description | Commands the ENCL to copy the coefficients from the specified channel to a Sensor Profile File so the sensor can be used as a replacement sensor. Generally this would only be used at the Scanivalve Factory, but it could be used by an end user to move a sensor from one module to another. The command may be entered from the local input or a host computer. The ENCL must be in the READY mode to accept the command. This command DOES NOT modify the tables in the ENCL system computer memory.   |
| Returns     | A file named: Tnnnnnnn.spf or Snnnnnnn.spf where T or S indicates the type of sensor and nnnnnnn indicates the sensor serial number. The file contains<br>LPRESS <Maximum Low Pressure><br>HPRESS <Maximum High Pressure><br>NEGPTS <Number of Negative Points><br><temp index> <pressure> <pressure counts><br><temp index> <pressure> <pressure counts><br>:: :: :: :: :: ::<br><temp index> <pressure> <pressure counts><br><nl><br><temp index> - The temperature in EC multiplied by four.<br><pressure> - The applied pressure<br><pressure counts> - The measured pressure counts<br><nl> - End of line  |
| Example     | Replacement sensors have been calibrated in a module. The data must be moved to Sensor Profile Files. The ENCL must be powered up and the sensor data must be in memory for this command to function correctly. The file containing the data will be named Tnnnnnnn.spf or Snnnnnnn.spf, where T indicates a replacement sensor for DSA3016 and S indicates a replacement sensor for a ZOC22, ZOC23, or ZOC33. The serial number of the sensor is indicated by nnnnnnn.<br>To create a Sensor Profile File for sensor T355 in port 8 of a module installed in position 3 of a ENCL type:<br>CREATESPF t355.spf 3-8<CR><br>The file: T355.spf will be created and written to the ENCL micro SD card. |
| Notes       | This command DOES NOT modify the tables in the ENCL system computer memory. The Sensor Profile File will be stored in the ENCL Folder. The file may be transferred to a host computer using a file transfer.  |

**DELETE**

|             |  |
|-------------|--|
| Command     | DELETE   |
| Syntax      | DELETE 0 69 [<channels>]<CR>   |
| Arguments   | 0 - the low point of the temperature planes to be deleted<br>69 - the high point of the temperature planes to be deleted<br>[<channels>] - optional, a channel to be deleted. This may be in the format:<br>module-port or serial number-port for a single module.<br>module-port..module-port or serial number-port..serial number-port<br>for a range of channels  |
| Description | Deletes all pressure points within temperature planes between 0 and 69 °C. Individual Temperature Planes may not be deleted. This allows new MASTER points to be entered via the INSERT command. NOTE: Refer to the description of the FILL command for more information.  |
| Returns     | <n> -end of line   |
| Example     | To delete the master points for all modules in a system using eight 16 channel modules, the following command would be issued:<br>DELETE 0 69 1-1..8-16<CR><br>To delete the master points for channels 1 through 16 in a DSA3016 installed in position six, the following command would be issued:<br>DELETE 0 69 6-1..6-16<CR><br>To delete the master points for channel 3 in a DSA3016 installed in position four, the following command would be issued:<br>DELETE 0 69 4-3<CR> |
| Notes       | Refer to the description of the FILL command for more information.   |

**DELETE FILE**

|             |   |
|-------------|---|
| Command     | DELETE FILE   |
| Syntax      | DEL <filename><CR>  |
| Arguments   | <filename> -the file to be deleted in the format: scanxxx.dat   |
| Description | Deletes data files from the ENCL folder on the ENCL onboard memory  |
| Returns     | <n> -end of line  |
| Example     | To delete the file, SCAN002.dat from the hard drive type:<br>DEL SCAN002.dat<br>To verify that the file was deleted, refer to the List Files Command. |
| Notes       | None.   |

**DELTA**

|             |  |
|-------------|--|
| Command     | DELTA  |
| Syntax      | DELTA <module><CR>   |
| Arguments   | <module> -the module position 1 through 8  |
| Description | Lists the active delta zero correction values that resulted from a CALIBRATE ZERO. These values are used in the conversion of raw counts to Engineering Units (EU). These variables can only be set by executing a CALIBRATE ZERO command. If a module number is not entered, the DELTA values for all active modules are listed.  |
| Returns     | DELTA: <channel> <value> <nl><br>DELTA: <channel> <value> <nl><br>:::<br>DELTA: <channel> <value> <nl><br><channel> -the channel in module-port format<br><value> -the zero correction values<br><nl> -end of line.  |
| Example     | To view the DELTA values for the module installed in position one type:<br>DELTA 1<CR><br><br>The ENCL will return the current delta values<br><br>DELTA: 1-1 40<br>DELTA: 1-2 38<br>DELTA: 1-3 29<br>DELTA: 1-4 31<br>::: :::<br>DELTA: 1-10 34<br>DELTA: 1-11 35<br>DELTA: 1-12 27<br>::: :::<br>DELTA: 1-15 30<br>DELTA: 1-16 29<br>>   |
| Notes       | Delta values are the difference between the current CALZ zero value and the zero value stored in the calibration coefficients. The values tend to be low when a module has been recently calibrated and increase slowly over time as the sensors drift. It is very important that a user execute a CALZ after the ENCL and DSA3016 modules have been allowed to stabilize after power up. Also a CALZ should be executed if power is cycled, or if a REBOOT, or RESTART command is executed. The Zero and Delta Arrays are cleared when the ENCL is powered down or when a REBOOT or RESTART command is executed. The data in the ZERO.cfg file is intended to be historical data. The Zero and Delta values are not reloaded at power up or restart because it is impossible to determine how long the power has been off. This also is designed to ensure that a new set of zeros is acquired if modules have been switched. |

**DIGITAL INPUT STATUS**

|             |   |
|-------------|---|
| Command     | DIGITAL INPUT STATUS  |
| Syntax      | DIN<CR>   |
| Arguments   | None  |
| Description | Reads the status word from the lattice chip   |
| Returns     | A sixteen bit status word. For more information, refer to the Status Word format table in this document.<br><nl> -end of line   |
| Example     | When this command is entered, the value of the status word is returned in hexadecimal notation. The value returned depends upon the status of the ENCL.<br>Type: DIN<CR><br>The ENCL will return the value: 2<br>If no frames are available, there are no digital inputs, no A/D errors have occurred and the FIFO's are empty. |
| Notes       | None  |

**DIGITAL OUTPUT STATUS**

|             |  |
|-------------|--|
| Command     | DIGITAL OUTPUT STATUS  |
| Syntax      | DOUT <discrete channel> <status><CR>   |
| Arguments   | <discrete channel> -a digital output channel 1 through 8<br><status> - 1=On; 0=Off   |
| Description | Commands the discrete output channel on or off.  |
| Returns     | <nl> -end of line  |
| Example     | In this example, digital output channel 1 will be energized, type:<br>DOUT 1 1<CR><br>In this example, digital output channel 4 will be energized, type:<br>DOUT 4 1<CR> |
| Notes       | None   |

**DISCONNECT FROM HOST**

|             |  |
|-------------|--|
| Command     | DISCONNECT FROM HOST   |
| Syntax      | DISCONNECT<CR>   |
| Arguments   | None   |
| Description | Disconnects the ENCL from the Host computer. Once this command is issued the Ethernet connection between the host and the ENCL will be cleanly disconnected. The host may re-connect to the ENCL by a normal TCP/IP connection method. |
| Returns     | <nl> -end of line  |
| Example     | To disconnect a ENCL from a host type:<br>DISCONNECT<CR>   |
| Notes       | None   |

**ERROR**

|             |   |
|-------------|---|
| Command     | ERROR   |
| Syntax      | ERROR<CR>   |
| Arguments   | None  |
| Description | Lists the errors that have occurred since the last CLEAR. Only the first 30 errors will be listed. If more than 30 errors have occurred, the message:<br>ERROR: Greater than 30 errors occurred<br>This error will appear at the end of the list. |
| Returns     | >   |
| Example     | None  |
| Notes       | This command is not functional in Version 5.07 and lower. It will return a prompt in response to the command.   |

**FILL**

|             |   |
|-------------|---|
| Command     | FILL  |
| Syntax      | FILL<CR>  |
| Arguments   | None  |
| Description | Sorts Fills the Conversion Table temperature planes in ascending order. The method used to FILL the conversion tables is determined by the setting of the variable: FILLONE. This variable is in the Conversion Group.<br>If FILLONE is set to zero, the FILL command will fill the conversion tables by calculating the temperature planes between Master Planes.<br>If FILLONE is set to one, the FILL command will copy the data in the first Master Plane encountered to all other planes. If a second Master Plane is encountered, the FILL will be terminated, and an error will be logged. |
| Returns     | <n> -end of line  |
| Example     | In this example, new MASTER points have been loaded and the coefficient table must be completed.<br>Type: FILL<CR><br>The FILL command only needs to be used if MASTER points are added to, or deleted from the coefficients and the program is not restarted. When the program is started, restarted, or reloaded, The MASTER points are loaded into memory from the Module Profile Files and a FILL is executed by the program.   |
| Notes       | None  |

**FRAME TRIGGER**

|             |  |
|-------------|--|
| Command     | FRAME TRIGGER  |
| Syntax      | TRIG   |
| Arguments   | None   |
| Description | This command acts as a software trigger to the ENCL. When ADTRIG is set to 1, an averaged frame of data will be output when the ENCL receives the TRIG command or a <TAB> character code (9 HEX or Control I). This will continue until a STOP command is issued or the Frames per Scan variable is met. The data format will depend upon the setting of EU, BIN and FORMAT. This command will also send the command set in the AUXSCHEM, and/or CALSCHEM variables. |
| Returns     | A single frame of scanned data.  |
| Example     | A scan command is executed with EU set to 1, BIN set to 0, ADTRIG set to 1, and FORMAT set to 0. The ENCL will wait for a Hardware trigger, the TRIG command or a <TAB> character (9 HEX or Control I). When one of the Data are scrolled and will be displayed as follows:<br>Frame # <number><br>Time <time> < $\mu$ s or ms><br><chan> <temp eu><br>" "<br>" "<br><chan> <temp eu><br>For information on other formats, refer to the SCAN command.                |

**INSERT**

|             |   |
|-------------|---|
| Command     | INSERT  |
| Syntax      | INSERT <temp> <channel> <pressure> <pressure counts> M<CR>  |
| Arguments   | <temp> -an integer from 0 to 69.75 that represents the temperature in °C.<br><channel> -a combination of module and port. Syntax is: module-port or serial number-port for one channel.<br><pressure> -a real number that represents the calibration pressure point.<br><pressure counts>- a signed integer from -32767 to 32767 that represents the control pressure counts from the sensor.   |
| Description | Inserts one pressure-pressure counts entry into the Correction Table. Only master points are accepted. The LIST MASTER and LIST ALL commands download the contents of the conversion table in the format required by this INSERT command.<br>If a MASTER plane is overwritten, an error will be generated.  |
| Returns     | <nl> -end of line   |
| Example     | Although INSERT commands are most often entered from a Module Profile File, they may be entered from a keyboard.<br>The following command will insert a master point at 30.5°C for channel 1 of the module installed in position 3. The applied pressure is 11.9998 psi, the measured counts are 26376.<br>INSERT 30.50 3-1 11.9998 26376 M<br><br>The following command will insert a master point at 48.75°C for channel 9 of the module installed in position 3. The applied pressure is 10.9998 psi, the measured counts are 20254.<br>INSERT 48.75 3-9 10.9998 20254 M<br><br>The following command will insert a master point at 43.75°C for channel 16 of module serial number 209. The applied pressure is -2.4864 psi, the measured counts are -6651.<br>INSERT 43.75 209-16 -2.4864 -6651 M |



**LIST ALL CONVERSION COEFFICIENTS**

|             |  |
|-------------|--|
| Command     | LIST ALL CONVERSION COEFFICIENTS   |
| Syntax      | LIST A <start temp> <end temp> <channels><CR>  |
| Arguments   | <start temp> -the lowest temperature plane to be returned<br><end temp> -the highest temperature plane to be returned<br><channels> -a combination of module and a port. Syntax is: module-port or Serial number-port for one channel.   |
| Description | Lists all of the master points in the temperature-pressure correction matrix. This command places the ENCL in the List mode until the command is completed or a stop command is issued.  |
| Returns     | INSERT <temp><channel><press><press counts><M><nl><br>INSERT <temp><channel><press><press counts><M, C, or I><nl><br>:::<br>INSERT <temp><channel><pressure><pressure counts><M><nl><br><temp> -the temperature plane<br><channel> -the channel in module-port notation<br><pressure> -the pressure in EU<br><pressure counts> -the A/D counts of pressure<br><M> -a Master Plane generated from a calibration<br><nl> -end of line.   |
| Example     | To list all of the coefficients from 14EC to 32EC for channel 1 in a module calibrated from 10°C to 40°C<br>Type: LIST a 14 32 1-1<CR><br>The ENCL will return a list of INSERT commands showing the temperature, channel, applied pressure, and counts:<br>INSERT 14.00 1-1 -5.958100 -21594 M<br>INSERT 14.00 1-1 -4.476100 -15127 M<br>INSERT 14.00 1-1 -2.994200 -8646 M<br>INSERT 14.00 1-1 -1.470100 -1973 M<br>INSERT 14.00 1-1 0.000000 4467 M<br>INSERT 14.00 1-1 1.470100 10917 M<br>INSERT 14.00 1-1 2.994200 17594 M<br>INSERT 14.00 1-1 4.476100 24098 M<br>INSERT 14.00 1-1 5.958100 30603 M<br>INSERT 23.25 1-1 -5.958100 -21601 M<br>INSERT 23.25 1-1 -4.476100 -15161 M<br>INSERT 23.25 1-1 -2.994300 -8714 M<br>INSERT 23.25 1-1 -1.470100 -2077 M<br>INSERT 23.25 1-1 0.000000 4332 M<br>INSERT 23.25 1-1 1.470100 10746 M<br>INSERT 23.25 1-1 2.994200 17397 M<br>INSERT 23.25 1-1 4.476100 23863 M<br>INSERT 23.25 1-1 5.958100 30333 M<br>INSERT 32.75 1-1 -5.958100 -21636 M<br>INSERT 32.75 1-1 -4.476100 -15214 M<br>INSERT 32.75 1-1 -2.994200 -8784 M<br>INSERT 32.75 1-1 -1.470100 -2162 M |
| Notes       | None   |

**LIST A/D CORRECTION TABLE (NON-TEMPERATURE COMPENSATED)**

|             |  |
|-------------|--|
| Command     | LIST A/D CORRECTION TABLE (NON-TEMPERATURE COMPENSATED)  |
| Syntax      | LIST A2DCOR <module><CR>   |
| Arguments   | <module> -The A/D location, 0 to 8 where 0 is the temperature A/D and 1 to 8 are the module locations  |
| Description | Lists the correction coefficients for the A/D in the specified location.   |
| Returns     | A2DCOR <module> <index> <applied voltage> <counts><br><module> -0 to 8, Where 0 is the temperature A/D in the and 1 to 8 are the module A/D's.<br><index> -the calibration point, up to 16 points may be entered, numbered 0 to 15.<br><applied> -voltage the voltage applied at the calibration point.<br><counts> -the A/D counts measured at the calibration point  |
| Example     | To list the coefficients for the A/D converter in A/D module 1 type:<br>LIST A2DCOR 1<CR><br>The ENCL will return:<br>A2DCOR 1 0 0.00000 0<br>A2DCOR 1 1 0.00000 0<br>A2DCOR 1 2 0.00000 0<br>A2DCOR 1 3 0.00000 0<br>A2DCOR 1 4 0.00000 0<br>A2DCOR 1 5 0.00000 0<br>A2DCOR 1 6 0.00000 0<br>A2DCOR 1 7 0.00000 0<br>A2DCOR 1 8 0.00000 0<br>A2DCOR 1 9 0.00000 0<br>A2DCOR 1 10 0.00000 0<br>A2DCOR 1 11 0.00000 0<br>A2DCOR 1 12 0.00000 0<br>A2DCOR 1 13 0.00000 0<br>A2DCOR 1 14 0.00000 0<br>A2DCOR 1 15 0.00000 0 |

***LIST CALIBRATION VARIABLES***

|             |   |
|-------------|---|
| Command     | LIST CALIBRATION VARIABLES  |
| Syntax      | LIST C<CR>  |
| Arguments   | None  |
| Description | Lists the conversion configuration variables from Group C   |
| Returns     | <pre>SET &lt;variable&gt; &lt;value&gt; &lt;nl&gt; ::: SET &lt;variable&gt; &lt;value&gt; &lt;nl&gt; &lt;variable&gt; -the configuration variable name &lt;value&gt; -the current setting &lt;nl&gt; -end of line.</pre>  |
| Example     | <p>To view the current conversion variable settings type: LIST C&lt;CR&gt;</p> <p>The ENCL will return the current conversion settings. They could appear as follows:</p> <pre>SET ZC 1 SET UNITSCAN psi SET CVTUNIT 1.000000 SET BIN 0 SET EU 1 SET CALZDLY 5 SET MPBS 0 SET CALPER 500 SET CALAVG 32 SET MAXEU 9999.00 SET MINEU -9999.00 SET STARTCALZ 0 SET FILLONE 0 SET A2DCOR 1 &gt;</pre> <p>For more information, refer to the Conversion Variable information in this manual.</p> |

**LIST BOOTLOADER GROUP VARIABLES**

|             |   |
|-------------|---|
| Command     | LIST BOOTLOADER GROUP VARIABLES   |
| Syntax      | LIST IP<CR>   |
| Description | Lists the identification variables from GROUP IP.   |
| Returns     | SET <variable> <value> <nl><br>:::<br>SET <variable> <value> <nl><br><variable> -the configuration variable name<br><value> -the current setting<br><nl> -end of line   |
| Example     | To view the current Boot Loader Group Variables settings type: LIST IP<CR><br>The ENCL will return the current boot loader variable settings. They could appear as follows.<br>SET IPADD 191.30.46.100<br>SET SUBNET 255.255.0.0<br>SET MAC 000.096.093.400.000.103<br>SET LOGIN Scanivalve<br>SET PASSWORD Scanner<br>SET LOGIN1 Scanivalve1<br>SET PASSWORD1 Scanner1<br>SET ALLOWANON 1<br>SET APP DSAENCL4000.hex<br>SET GW 0.0.0.0 |
| Notes       | Modifications to the variables in this group may result in unstable network operation, problems completing FTP file transfers or enclosure operational problems. The variables in this group are not saved when a SAVE command is issued. They may only be saved by using the SAVEIP command.   |

**LIST DIGITAL VARIABLES**

|             |  |
|-------------|--|
| Command     | LIST DIGITAL VARIABLES   |
| Syntax      | LIST D<CR>   |
| Arguments   | None   |
| Description | Lists the Digital Configuration variables from Group D   |
| Returns     | SET <variable> <value> <nl><br>:::<br>SET <variable> <value> <nl><br><variable> -the configuration variable name<br><value> -the current setting<br><nl> -end of line  |
| Example     | To view the current digital variable settings type: LIST D<CR><br>The ENCL will return the current digital settings. They could appear as follows.<br>SET DOUTPU 0<br>SET DOUTCALZ 60<br>SET DOUTPGSEQ 0<br>SET DOUTPG 0<br>SET DOUTSCAN 4<br>SET DLYPGSEQ 1<br>SET DLYPG 10<br>SET DOUTREADY 8<br>SET BANKA 0<br>SET BANKB 0<br>SET BANKUSR 0 |

**LIST FILE CONTENTS**

|             |   |
|-------------|---|
| Command     | LIST FILE CONTENTS  |
| Syntax      | TYPE <filename><CR>   |
| Arguments   | <filename> -The file to be listed. The file must be in the ENCL Folder.   |
| Description | Lists the contents of the named file. This command is intended to allow a user to check the contents of one of the setup files on the onboard memory.   |
| Returns     | <nl> -end of line   |
| Example     | <p>To list the contents of the CV.gpf file, type: TYPE CV.gpf&lt;CR&gt;<br/>                     The contents of the file will be listed. The variables listed below are sampling of an actual cv.gpf file</p> <pre>                     SET NL 0                     SET DISPIN 0                     SET HAVENET 1                     SET HAVEARINC 0                     SET CONOUT 2                     SET NETOUT 2                     SET FORMAT 0                     SET NETIN 1                     SET IFUSER 1                     SET ECHO 0                     SET CAL 0 9600                     SET CALSCHED 0 rp 0                     SET AUX 0 9600 1                     SET AUXSCHED 0 rp 0                     SET RESCAN 0 0                     :: :: ::                     :: :: ::                     :: :: ::                     SET MPBS 5                     SET CALPER 500                     SET CALAVG 64                     SET MAXEU 9999.00                     SET MINEU -9999.00                     SET STARTCALZ 2727                     SET FILLONE 0                     SET A2DCOR 1                     SET SIMTMODE OFF                     SET SIMTEMP 25.00                     &gt;                 </pre> |
| Notes       | None  |

**LIST FILES**

|             |   |
|-------------|---|
| Command     | LIST FILES  |
| Syntax      | DIR<CR>   |
| Arguments   | None  |
| Description | Lists the data files stored in the ENCL folder on the onboard memory. Data file names are in the standard DOS format: 8.3, where there are 8 characters for the file name and 3 for the extension.  |
| Returns     | <filename> <nl><br>:<br>:<br>:<br><filename> <nl><br><nl><br><filename> -The data file name<br><nl> -end of line.   |
| Example     | To list all data files stored In the ENCL folder on the ENCL hard disk drive type: DIR<CR><br>The ENCL will return a file list<br>Encl4000.hex 435056<br>ip.cfg 283<br>sn.gpf 117<br>CV.GPF 935<br>zero.cfg 1656<br>a2d.cfg 3542<br>a2dcoef.cfg 229<br>M1986.MPF 28569<br>M1980.MPF 28372<br>M1982.MPF 28659<br>M1984.MPF 28500 |

**LIST GAIN VARIABLES**

|             |   |
|-------------|---|
| Command     | LIST GAIN VARIABLES   |
| Syntax      | LIST G <module><CR>   |
| Arguments   | <module> - The module location 1 through 8.   |
| Description | Lists the active temperature gain set for the module from the Temperature Gain group, Group G. Module may be the position or the serial number. These data are used to convert temperature counts to °C. This is the “M” term in the temperature characterization equation. The value of this term will vary based on the module type. Refer to the section on Temperature Gain Values in the Configuration Variable Section of this manual for more information on the values for the “M” Terms.   |
| Returns     | SET TEMPMn <value><nI><br>n -The module position or the serial number<br><value> -The temperature gain value for module n<br><nI> -end of line.   |
| Example     | To verify the temperature gain setting for the module serial number 253, type: LIST g 253<CR><br>The ENCL will return:<br>SET TEMPM253 0.023559<br>The gain settings may also be verified by module location. To verify the temperature gain setting of the module installed in position 6, type: LIST g 6<CR><br>The ENCL will return:<br>SET TEMPM6 0.023559<br>The temperature gain settings may be verified for all modules installed in the ENCL.<br>Type: LIST g<CR><br>The ENCL may return:<br>SET TEMPM1 0.023559<br>SET TEMPM2 0.023559<br>SET TEMPM3 0.023559<br>SET TEMPM4 0.023559<br>SET TEMPM5 0.023559<br>SET TEMPM6 0.023559<br>SET TEMPM7 0.023559<br>SET TEMPM8 0.023559<br>> |

**LIST ID CHIP IDENTIFICATION**

|             |   |
|-------------|---|
| Command     | LIST ID CHIP IDENTIFICATION   |
| Syntax      | LIST ID [<location> <site> <device>]<CR>  |
| Arguments   | <location> -the ID chip location, 0 to 16<br><site> -the location type, where: A=A/D module, M=DSA3016 module<br><device> -must be E for EPROM  |
| Description | Lists the ID chip identification information. DSA3016 modules may only be site 1 through 8. A/D modules may be sites 0 through 8 where the Temperature A/D module can only be site 0. Digital modules are site 9.   |
| Returns     | <index> <location> <site> <device> <ID> <error><br><index> -Line number, used for reference only<br><location> -the ID chip location, 0 to 16<br><site> -the location type, Where: A = A/D module, M = DSA3016 module<br><device> -E = EPROM, T = Temp, S = Switch<br><ID> -the chip ID number - This number is unique for each ID chip.<br><error> -any error that may have occurred   |
| Example     | <p>EXAMPLE 1 To view all of the ID information of a ENCL and a DSA3016 installed in position 1 type: LIST ID&lt;CR&gt;</p> <p>The ENCL may return:</p> <pre>0 1 A T 28644c340000008f None 1 0 A T 286e4c3400000040 None 2 0 A T 28cddb460000000c None 3 1 A E 14ca251e010000f3 None 4 0 A E 142e8e1e01000045 None 5 1 M E 147524ef00000048 None 6 2 A T 28b1de460000003b None 7 2 A E 14e9251e0100001c None 8 9 D E 14ee241e01000054 None</pre> <p>EXAMPLE 2 To view the ID information of the DSA3016 module in location 1 type: LIST ID 1 M E</p> <p>The ENCL may return:</p> <pre>5 1 M E 147524ef00000048 None</pre> <p>EXAMPLE 3 To view the ID information of the A/D module in location 2 type: LIST ID 2 A E</p> <p>The ENCL may return:</p> <pre>7 2 A E 14e9251e0100001c None</pre> <p>EXAMPLE 4 To View the ID information of a typical ENCL type: LIST ID</p> <p>The Enclosure may return:</p> <pre>0 1 A T 28644c340000008f None 1 0 A T 286e4c3400000040 None 2 0 A T 28cddb460000000c None 3 1 A E 14ca251e010000f3 None 4 0 A E 142e8e1e01000045 None 5 2 A T 28b1de460000003b None 6 2 A E 14e9251e0100001c None 7 9 D E 14ee241e01000054 None</pre> |
| Notes       | None  |



**LIST ID CHIP SETTINGS**

|             |   |
|-------------|---|
| Command     | LIST ID CHIP SETTINGS   |
| Syntax      | LIST IDP [<location> <site> <device> <mem>]<CR>   |
| Arguments   | <location> -the ID chip location 1 to 8<br><site> -the location type, Where: A=A/D module, M=DSA3016 module<br><device> -thedevice type, always E for EPROM<br><mem> -the memory type, Where: E=EPROM, P=PROM   |
| Description | Lists the ID chip settings. DSA3016 modules may only be site 1 through 8. A/D modules may be sites 1 through 8. If the location, site, and device are not specified, the settings for all chips will be returned.   |
| Returns     | SET IDP <loc> <site> <device> <mem> <name> <value><br><loc> -the ID chip location, 1 to 8<br><site> -the location type, Where: A = A/D module, M = DSA3016 module<br><device> -the device type, always E for EPROM<br><mem> -the memory type, Where: P = PROM, E = EPROM<br><name> -the parameter name<br><value> -the parameter value  |
| Example     | <p>EXAMPLE 1 To view all of the ID chip information of the chip in A/D module in position 1 type:<br/>LIST IDP 1 A&lt;CR&gt;<br/>The ENCL may return:<br/>SET IDP 1 A E P DFC 1<br/>SET IDP 1 A E P DMC 0<br/>SET IDP 1 A E P SN 111<br/>SET IDP 1 A E P REV A<br/>SET IDP 1 A E P MDATE 7/1/2002<br/>SET IDP 1 A E E ADCA 0.000000<br/>SET IDP 1 A E E ADCB 0.996481<br/>SET IDP 1 A E E ADCC 2.070793<br/>SET IDP 1 A E E ECC 0.001499<br/>SET IDP 1 A E E GAIN 0<br/>SET IDP 1 A E E ACDATE 7/1/2002<br/>SET IDP 1 A E E ADCD 6.50000</p> <p>EXAMPLE 2 To view the ID chip information of the chip in the DSA3016 module in position 1:<br/>Type: LIST IDP 1 M&lt;CR&gt;<br/>The ENCL may return:<br/>SET IDP 1 M E P DFC 2<br/>SET IDP 1 M E P DMC 4<br/>SET IDP 1 M E P SN 301<br/>SET IDP 1 M E P REV A<br/>SET IDP 1 M E P MDATE 1/27/2000<br/>SET IDP 1 M E E RTYPE 0<br/>SET IDP 1 M E E RVALUE 1<br/>SET IDP 1 M E E RCORA 0.000000<br/>SET IDP 1 M E E RCORB 0.000000<br/>SET IDP 1 M E E RCDATE 1/27/2000<br/>SET IDP 1 M E E PCDATE 8/16/2002<br/>SET IDP 1 M E E NPR1 15.000000<br/>SET IDP 1 M E E NPR2 15.000000<br/>SET IDP 1 M E E VALVE 1<br/>SET IDP 1 M E E XDUCER 0</p> |
| Notes       | None  |

***LIST IDENTIFICATION VARIABLES***

|             |   |
|-------------|---|
| Command     | LIST IDENTIFICATION VARIABLES   |
| Syntax      | LIST I<CR>  |
| Arguments   | None  |
| Description | Lists the Identification configuration variables from Group I.  |
| Returns     | <pre> SET &lt;variable&gt; &lt;value&gt; &lt;nl&gt; SET &lt;variable&gt; &lt;value&gt; &lt;nl&gt; ::: SET &lt;variable&gt; &lt;value&gt; &lt;nl&gt; &lt;variable&gt; -the configuration variable name &lt;value&gt; -the current setting &lt;nl&gt; -end of line.</pre>   |
| Example     | <p>To verify the general module configuration settings type: LIST I&lt;CR&gt;</p> <p>The ENCL may return:</p> <pre> SET NL 0 SET DISPIN 0 SET HAVENET 1 SET HAVEARINC 0 SET CONOUT 2 SET NETOUT 2 SET FORMAT 0 SET NETIN 1 SET IFUSER 1 SET ECHO 0 SET CAL 0 9600 SET CALSCHED 0 rp 0 SET AUX 0 9600 1 SET AUXSCHED 0 rp 0 SET RESCAN 0 0 SET TWOAD 1</pre> |
| Notes       | None  |

**LIST MASTER CONVERSION COEFFICIENTS**

|             |  |
|-------------|--|
| Command     | LIST MASTER CONVERSION COEFFICIENTS  |
| Syntax      | LIST M <start temp> <end temp> [<channels>]<CR>  |
| Arguments   | <start temp> -The lowest temp plane to be returned.<br><end temp> -The highest temp plane to be returned.<br>[<channels>] -channels is a the combination of module and a port. Syntax is: module-port or Serial Number-port for one channel  |
| Description | Lists all of the Master Points in the temperature-pressure correction matrix. This command places the ENCL in the LIST mode until the command is completed or a STOP command is issued.  |
| Returns     | INSERT <temp><channel><press><press counts>M<nl><br>:::<br>INSERT <temp><channel><press><press counts> M<nl><br><temp > -the temperature plane<br><channel> -the channel in module-port or serial number-port notation<br><pressure> -the pressure in EU<br><pressure counts> -the A/D counts of pressure<br>M -indicates this is a Master Plane<br><nl> -end of line  |
| Example     | To view the Master Points between 10°C and 40°C for channel 1 of the module installed in position 1 type: List M 10 40 1-1<CR><br>The ENCL may return:<br>INSERT 14.00 1-1 -5.958100 -21594 M<br>INSERT 14.00 1-1 -4.476100 -15127 M<br>INSERT 14.00 1-1 -2.994200 -8646 M<br>INSERT 14.00 1-1 -1.470100 -1973 M<br>INSERT 14.00 1-1 0.000000 4467 M<br>INSERT 14.00 1-1 1.470100 10917 M<br>INSERT 14.00 1-1 2.994200 17594 M<br>INSERT 14.00 1-1 4.476100 24098 M<br>INSERT 14.00 1-1 5.958100 30603 M<br>INSERT 23.25 1-1 -5.958100 -21601 M<br>INSERT 23.25 1-1 -4.476100 -15161 M<br>INSERT 23.25 1-1 -2.994300 -8714 M<br>INSERT 23.25 1-1 -1.470100 -2077 M<br>INSERT 23.25 1-1 0.000000 4332 M<br>INSERT 23.25 1-1 1.470100 10746 M<br>INSERT 23.25 1-1 2.994200 17397 M<br>INSERT 23.25 1-1 4.476100 23863 M<br>INSERT 23.25 1-1 5.958100 30333 M<br>INSERT 32.75 1-1 -5.958100 -21636 M<br>INSERT 32.75 1-1 -4.476100 -15214 M<br>INSERT 32.75 1-1 -2.994200 -8784 M<br>INSERT 32.75 1-1 -1.470100 -2162 M<br>INSERT 32.75 1-1 0.000000 4228 M<br>INSERT 32.75 1-1 1.470100 10615 M<br>INSERT 32.75 1-1 2.994200 17246 M<br>INSERT 32.75 1-1 4.476100 23691 M<br>INSERT 32.75 1-1 5.958100 30136 M |
| Notes       | None   |

**LIST MODULE INFORMATION VARIABLES**

|             |  |
|-------------|--|
| Command     | LIST MODULE INFORMATION VARIABLES  |
| Syntax      | LIST MI <modules><CR>  |
| Arguments   | <module> -module group 1 through 8 or module serial number   |
| Description | Lists the configuration variables from Groups M1 through M8. If the module is not identified, all modules are listed. Each module information group has provisions for up to four comment lines. These lines may be used to aid in the identification of the module group.   |
| Returns     | <pre> REM&lt;module&gt; 1 &lt;comment&gt; &lt;nl&gt; REM&lt;module&gt; 2 &lt;comment&gt; &lt;nl&gt; REM&lt;module&gt; 3 &lt;comment&gt; &lt;nl&gt; REM&lt;module&gt; 4 &lt;comment&gt; &lt;nl&gt; SET &lt;variable&gt; &lt;value&gt; &lt;nl&gt; SET &lt;variable&gt; &lt;value&gt; &lt;nl&gt; ::: SET &lt;variable&gt; &lt;value&gt; &lt;nl&gt; &lt;variable&gt; -the configuration variable name &lt;value&gt; -the current setting &lt;nl&gt; -end of line.</pre>  |
| Example     | <p>EXAMPLE 1 To view the configuration of the DSA3016 module installed in position 1,<br/>Type: LIST MI 1&lt;CR&gt;<br/>The ENCL may return:</p> <pre> REM1 1 Comment line 1 REM1 2 Comment line 2 REM1 3 Comment line 3 REM1 4 Comment line 4 SET TYPE1 0 SET ENABLE1 1 SET NUMPORTS1 16 SET NPR1 5 SET LPRESS1 1..16 -6.100000 SET HPRESS1 1..16 6.100000 SET NEGPTS1 1..16 4 SET MODTEMP1 0 1.000000 &gt;</pre> <p>EXAMPLE 2 To view the configuration of the module installed in position 7,<br/>Type: LIST MI 7&lt;CR&gt;<br/>The ENCL may return:</p> <pre> REM7 1 Comment line 1 REM7 2 Comment line 2 REM7 3 Comment line 3 REM7 4 Comment line 4 SET TYPE7 0 SET ENABLE7 1 SET NUMPORTS7 16 SET NPR7 5 SET LPRESS7 1..16 -5.5500000 SET HPRESS7 1..16 5.5500000 SET NEGPTS7 1..16 4 SET MODTEMP7 0 1.000000</pre> |
| Notes       | None   |

***LIST NETWORK ATTACHED STORAGE VARIABLES***

|             |   |
|-------------|---|
| Command     | LIST NETWORK ATTACHED STORAGE VARIABLES   |
| Syntax      | LIST NAS<CR>  |
| Arguments   | None  |
| Description | Lists the Network Attached Storage Variables from Group NAS.  |
| Returns     | <pre> SET &lt;variable&gt; &lt;value&gt; &lt;nl&gt; SET &lt;variable&gt; &lt;value&gt; &lt;nl&gt; ::: SET &lt;variable&gt; &lt;value&gt; &lt;nl&gt; &lt;variable&gt; -the configuration variable name &lt;value&gt; -the current setting &lt;nl&gt; -end of line.                     </pre>  |
| Example     | <p>To view the current digital variable settings type: LIST NAS&lt;CR&gt;<br/> The DSAENCL4000 will return the current digital settings. They could appear as follows.</p> <pre> SET USERNAS admin SET PASSNAS password SET ENNAS 0 SET PATHNAS /ENCL4000 SET IPNAS 10.0.1.220 SET FILENAS Scan SET ENNTP 0 SET ITPNTP 10.0.0.1 SET UTCCOFFSET -8 &gt;                     </pre> |
| Notes       | None  |

**LIST OFFSET VARIABLES**

|             |  |
|-------------|--|
| Command     | LIST OFFSET VARIABLES  |
| Syntax      | LIST 0 <module><CR>  |
| Arguments   | None   |
| Description | Lists the active temperature offsets set for the module from the Temperature Offset Group, Group O. This data is used to convert temperature counts to °C. This is the “B” term in the temperature characterization equation. The value of this term will vary based on the module type. Refer to the section on Temperature Offset Values in the Configuration Variables Section of this manual for more information on the values for the “B” terms.   |
| Returns     | SET TEMPBn <value> <nI><br>n -the module position or serial number<br><value> -the current setting<br><nI> -end of line.   |
| Example     | <p>To verify the the temperature offset setting for the module serial number 253, type: LIST O 253&lt;CR&gt;<br/>The ENCL will return:<br/>SET TEMPB253 -198.514371</p> <p>The offset settings may also be verified by module location. To verify the temperature offset setting of the module installed in position 6, type: LIST O 6&lt;CR&gt;<br/>The ENCL will return:<br/>SET TEMPB6 -198.514371</p> <p>The temperature offset settings may be verified for all modules installed in the ENCL, type:<br/>LIST O&lt;CR&gt;<br/>The ENCL may return:<br/>SET TEMPB1 -198.514371<br/>SET TEMPB2 -198.514371<br/>SET TEMPB3 -198.514371<br/>SET TEMPB4 -198.514371<br/>SET TEMPB5 -198.514371<br/>SET TEMPB6 -198.514371<br/>SET TEMPB7 -198.514371<br/>SET TEMPB8 -198.514371<br/>&gt;</p> |
| Notes       | None   |

***LIST PROFILE LIST***

|             |   |
|-------------|---|
| Command     | LIST PROFILE LIST   |
| Syntax      | LIST P<CR>  |
| Arguments   | None  |
| Description | Lists the Installed module serial numbers from the Serial Number Profile Group, Group P. These data are used to create Module Profile Files that will hold module specific configuration variables. When the ENCL is first booted up, or when a REBOOT command is entered, The software reads the values set in this list and maps the coefficients in the respective MPF files into memory. If a MPF file is not found, default values for the module information data are used. After the initialization is complete, the software searches for ID chip information. If the ID chip information matches the Profile List, no changes are made. If the ID chip information is different from the Profile list, the Profile List is updated. ID chip information will also override Module Information. |
| Returns     | SET ENCLSN <value> <nl><br>SET SN1 <value> <nl><br>SET SN2 <value> <nl><br>:::<br>SET SN8 <value> <nl><br><value> -the serial number of the module installed at that location<br><nl> -end of line.   |
| Example     | To Verify the module input configuration<br>Type: LIST P<CR><br>The ENCL may return:<br>SET ENCLSN 103<br>SET SN1 253<br>SET SN2 0<br>SET SN3 0<br>SET SN4 0<br>SET SN5 0<br>SET SN6 0<br>SET SN7 0<br>SET SN8 0<br>>   |
| Notes       | If serial numbers are not entered, the conversion coefficients will not load.   |

***LIST SYSTEM COMPONENTS***

|             |  |
|-------------|--|
| Command     | LIST SYSTEM COMPONENTS   |
| Syntax      | LIST SYS [<U> or <S>]<CR>  |
| Arguments   | blank - the existing system information, as determined at power up will be displayed. No data will be updated.<br><U> - the system information will be updated and displayed<br><S> -system information will be displayed using simulated ID chips |
| Description | Lists the system information. This is the same information displayed at power up. This command must be run when system changes are made after power up.  |
| Returns     | ENCL Serial Number N<br>LOC A2DSN -MODEL- -SN- CHAN VALVE -NPR1- -NPR2- XDUCER -CAL-DATE-<br>1<br>2<br>3<br>4<br>5<br>6<br>7<br>8<br>LOC -MODEL- -SN- CHAN DESCRIPTION<br>9<br>10<br>11<br>12<br>13<br>14<br>15<br>16                              |



| Command | LIST SYSTEM COMPONENTS   |
|---------|--|
| Example | <p>EXAMPLE 1 To view the current System Information as determined at power up:<br/>                     Type: LIST SYS&lt;CR&gt;<br/>                     The ENCL will return:<br/>                     ENCL Serial Number 103<br/>                     LOC A2DSN -MODEL- -SN- CHAN VALVE -NPR1- -NPR2- XDUCER -CAL-DATE-<br/>                     1 111 DSA3016 300 16 IP 15.00 15.00 DIF 3/16/2005<br/>                     2 110 DSA3016 311 16 IP 30.00 50.00 DIF 3/18/2005<br/>                     3 DSA3016 325 16 IP 100.00 100.00 DIF 3/18/2005<br/>                     4 DSA3016 326 16 IP 100.00 100.00 DIF 3/18/2005<br/>                     5 DSA3016 341 16 IP 100.00 100.00 DIF 3/19/2005<br/>                     6 DSA3016 344 16 IP 300.00 300.00 DIF 3/19/2005<br/>                     7 DSA3016 345 16 IP 300.00 300.00 DIF 3/19/2005<br/>                     8 DSA3016 361 16 IP 750.00 750.00 DIF 3/20/2005<br/>                     LOC -MODEL- -SN- CHAN DESCRIPTION<br/>                     9<br/>                     10<br/>                     11<br/>                     12<br/>                     13<br/>                     14<br/>                     15<br/>                     16<br/>                     DSA3016 SN300 has 16 channels The Full Scale pressure range of the module is 15 psi. The module is set up as a normal Differential Pressure Module. It was last calibrated March 16, 2005.<br/>                     DSA3016 SN311 has 16 channels. It is a Dual Range module with full scale ranges of 30 and 50 psi. The module is set up as a normal Differential Pressure Module. It was last calibrated March 18, 2005.<br/>                     DSA3016 SN325 has 16 channels The Full Scale pressure range of the module is 100 psi. The module is set up as a normal Differential Pressure Module. It was last calibrated March 18, 2005.<br/>                     DSA3016 SN326 has 16 channels The Full Scale pressure range of the module is 100 psi. The module is set up as a normal Differential Pressure Module. It was last calibrated March 18, 2005.<br/>                     DSA3016 SN341 has 16 channels The Full Scale pressure range of the module is 100 psi. The module is set up as a normal Differential Pressure Module. It was last calibrated March 19, 2005.<br/>                     DSA3016 SN344 has 16 channels The Full Scale pressure range of the module is 300 psi. The module is set up as a normal Differential Pressure Module. It was last calibrated March 19, 2005.<br/>                     DSA3016 SN345 has 16 channels The Full Scale pressure range of the module is 300 psi. The module is set up as a normal Differential Pressure Module. It was last calibrated March 19, 2005.<br/>                     DSA3016 SN361 has 16 channels The Full Scale pressure range of the module is 750 psi. The module is set up as a normal Differential Pressure Module. It was last calibrated March 20, 2005</p> |
| Notes   | <p>All positions do not have to be filled. The positions are identified by the setting of the dip switches on the A/D modules. A standard ENCL will only have 2 A/D modules installed. A/D 1 will scan modules installed in positions 1 through 4. A/D 2 will scan module installed in positions 5 through 8. A special order version of the ENCL is available with 8 A/D modules. A List SYS U command will not update the module profile file, nor the module information read from the mpf files during a boot up or restart. If a module is swapped out, or if a module position is changed after the program has started, the program MUST be restarted for the module information to be updated.</p>   |

**MERGE SENSOR PROFILE FILE**

|             |  |
|-------------|--|
| Command     | MERGE SENSOR PROFILE FILE  |
| Syntax      | MERGESPf <sensor profile file> <module profile file> <port number> <CR>  |
| Arguments   | <sensor profile file> -the file containing the replacement sensor data<br><module profile file> -the file where the sensor data will be added<br><port number> -the location of the new sensor   |
| Description | Commands the ENCL to merge the coefficients for a replacement sensor from a Sensor Profile File into a Module Profile File. The Sensor Profile File must reside in the same directory as the Module Profile File. In a ENCL, this will be the ENCL Folder. For more information on file transfers, please refer to the file transfer procedures in this manual. The command may be entered from the system computer or a host computer. The ENCL must be in the READY mode to accept the command. This command DOES NOT modify the tables in the ENCL system computer memory. The new coefficients will not be effective until the program is restarted. |
| Returns     | <nl> -End of line  |
| Example     | Replacement sensor data will be provided on a floppy disk. The file containing the data will be named Tnnnnnn.spf or Snnnnnn.spf, where T indicates a replacement sensor for DSA3016 and S indicates a replacement sensor for a ZOC22, ZOC23, or ZOC33. The serial number of the sensor is indicated by nnnnnnn.<br>When the SPF file has been installed on the ENCL, the sensor data may be added to the MPF file.<br>To install the coefficients from sensor T355 in port 8 of module serial number 150 type:<br>MERGESPf t355.spf m150.mpf 8<CR>  |
| Notes       | The ENCL program must be restarted for the new coefficients to be effective.<br>The program may be restarted by the RESTART command or by cycling power.   |

**REBOOT**

|             |  |
|-------------|--|
| Command     | REBOOT   |
| Syntax      | REBOOT<CR>   |
| Arguments   | None   |
| Description | Commands the ENCL software to restart the DSAENCL4000.hex program. |
| Returns     | Nothing  |
| Example     | To initiate a REBOOT sequence type: REBOOT<CR>                     |

**RESTART**

|             |  |
|-------------|--|
| Command     | RESTART  |
| Syntax      | RESTART<CR>  |
| Arguments   | None   |
| Description | Commands the ENCL software to restart the DSAENCL4000.hex program. |
| Returns     | Nothing  |
| Example     | To initiate a RESTART sequence type: RESTART<CR>                   |

**RESET SEQUENCE NUMBER**

|             |  |
|-------------|--|
| Command     | RESET SEQUENCE NUMBER  |
| Syntax      | RSTSEQ [<Sequence Start>] <CR>   |
| Arguments   | blank -the sequence number will be reset to 0000.<br><Sequence Start> -the sequence number will be reset to the number entered |
| Description | Resets the sequence number used to complete the file name when Network Attached Storage is enabled.                            |
| Returns     | <n> -end of line   |
| Example     | To reset the Sequence Number to 0000, type:<br>RSTSEQ <CR><br>To reset the Sequence Number to 0100, type:<br>RSTSEQ 100 <CR>   |
| Notes       | This command is only active when NAS is enabled.   |

**PURGE**

|             |   |
|-------------|---|
| Command     | PURGE   |
| Syntax      | PURGE<CR>   |
| Arguments   | None  |
| Description | <p>Commands the ENCL to initiate a purge sequence. This command may be initiated by entering the command from the local system computer or a host computer. The ENCL must be in the READY mode. The purge sequence is:</p> <ol style="list-style-type: none"> <li>1. The digital output are set according to the DOUTPGSEQ variable.</li> <li>2. The output remain set for a delay time set by the DLYPGSEQ variable.</li> <li>3. When DLYPGSEQ times out, the digital output are set according to the DOUTPG variable.</li> <li>4. The digital output will remain set until the DLYPG variable is met or until a STOP command is issued.</li> <li>5. When DLYPG times out or when a STOP command is received the digital output are set according to the DOUTPGSEQ variable.</li> <li>6. The output remain set for a delay time set by the DLYPGSEQ variable.</li> <li>7. When DLYPGSEQ times out, the ENCL returns to the READY mode.</li> </ol> <p>When a purge is initiated by a digital input, the ENCL may be in the READY mode or in the SCAN mode. The purge sequence is the same as above unless the ENCL is in the SCAN mode. If the ENCL is in the SCAN mode, the scanning will be suspended until the purge sequence is completed. At that time scanning will be resumed.</p> |
| Returns     | <n> -End of line  |
| Example     | To initiate a PURGE sequence type: PURGE<CR>  |
| Notes       | <p>The Purge sequence may be terminated before the sequence is completed by issuing a STOP command, or by pressing the escape key from a serial or Ethernet connection. When the sequence is terminated early, the control valve sequencing will follow the normal end of sequence timing. For example:</p> <p>A PURGE command is issued to the enclosure. The valves are sequenced as set in DOUTPGSEQ and DLYPGSEQ. When DLYPGSEQ times out, the control valves are set to DOUTPG and the DLYPG timer starts. A STOP command is issued before the DLYPG time has timed out. The control valves are immediately set to the DOUTPGSEQ values and the DLYPGSEQ timer starts. When this timer times out, the enclosure exits the PURGE mode and waits for another command.</p>  |

**SAVE**

|             |  |
|-------------|--|
| Command     | SAVE   |
| Syntax      | SAVE [modules]<CR>   |
| Arguments   | [Modules] -Syntax is:<br>module     for one module<br>module, module, module     for several modules<br>module..module     for a range of modules<br>Module is the physical location of the module in the ENCL   |
| Description | Commands the ENCL to save the configuration variables (with the exception of groups IP and NAS) and correction tables to the Micro SD or flash Card. Correction tables are saved as .MPF files for all modules specified in the command. If a module, several modules, or a range of modules is not specified, the correction tables for all enabled modules will be saved.<br><br>The following files are updated when a SAVE command is issued:<br>SN.cfg -The P group configuration variables<br>ZERO.cfg -The current ZERO and DELTA data from the most recent CALZ<br>Mxxxx.mpf -The module calibration coefficients, where xxxx is the module serial number.<br>CV.gpf -All other configuration variables<br>A2D.cfg -The A/D correction coefficients. |
| Returns     | <nl> -End of line  |
| Example     | To save the current configuration variable settings and conversion coefficients for all enabled modules type: SAVE<CR><br><br>To save the current configuration variable settings and conversion coefficients for module 4 only type: SAVE 4<CR><br><br>To save the current configuration variable settings and conversion coefficients for modules 1, 3, and 7 only type: SAVE 1,3,7<CR><br><br>To save the current configuration variable settings and conversion coefficients for modules 3, 4, 5, 6 and 7 only type: SAVE 3..7<CR>   |
| Notes       | The SAVE command requires approximately 60 seconds to complete. Normally, commands entered during this time would be ignored, but it is possible on rare occasions to cause the enclosure firmware to freeze.  |

**SAVE BOOT LOADER VARIABLES**

|             |  |
|-------------|--|
| Command     | SAVE BOOT LOADER VARIABLES   |
| Syntax      | SAVEIP<CR>   |
| Arguments   | None   |
| Description | <p>Commands the ENCL to save the boot loader configuration variables to the Micro SD Card. Boot loader configuration variables are saved to the ip.cfg file.</p> <p>The SAVEIP write process requires two commands to complete.</p> <ol style="list-style-type: none"> <li>1. The SAVEIP command stages the IP configuration variables and prepares the software to write to the Micro SD Card. This command does not actually perform the write.</li> <li>2. The write process does not occur until a SAVEIPCONFIRM command is issued. The SAVEIPCONFIRM command is considered to be part of the SAVEIP command.</li> </ol> |
| Returns     | None   |
| Example     | <p>To save the current bootloader configuration variable settings, type: SAVEIP&lt;CR&gt;</p> <p>The software will return the following message:</p> <p>WARNING: This action could cause network communication problems.</p> <p>Type SAVEIPCONFIRM confirm SAVEIP or STOP to cancel the operation.</p> <p>Type: SAVEIPCONFIRM to complete the SAVE.</p>  |
| Notes       | <p>Changes to the bootloader configuration variables will not take effect until power is cycled, or a REBOOT command is issued.</p> <p>The SAVEIP command requires approximately 60 seconds to complete. Normally, commands entered during this time would be ignored, but it is possible on rare occasions to cause the enclosure firmware to freeze.</p>   |

**SAVE NETWORK ATTACHED STORAGE VARIABLES**

|             |   |
|-------------|---|
| Command     | SAVE NETWORK ATTACHED STORAGE VARIABLES   |
| Syntax      | SAVENAS<CR>   |
| Arguments   | None  |
| Description | <p>Commands the DSAENCL4000 to save the Network Attached Storage(NAS) configuration variables to the onboard memory. NAS configuration variables are saved to the nas.cfg file.</p> |
| Returns     | None  |
| Example     | To save the current NAS configuration variable settings type: SAVENAS<CR>   |
| Notes       | Changes to the NAS configuration variables are not saved during a SAVE or SAVEIP command.   |

**SCAN**

|             |   |
|-------------|---|
| Command     | SCAN  |
| Syntax      | SCAN<CR>  |
| Arguments   | None  |
| Description | Commands the ENCL to scan the pressure sensors and output scan data according to the scan rate and fps settings, and will output the data to the configured destination.  |
| Returns     | Scan data<br>If BIN is set to a non-zero number, the Scan Packets are returned in Binary Format (Refer to the section on Binary Data Packets for more information and packet structure).<br>If BIN is set to 0, the scan packets are returned in ASCII in the format configured by the FORMAT variable.   |
| Example     | EXAMPLE A scan group is set up to display 16 channels of module 1 with fps and format set to 1<br>Type: SCAN<CR><br>The ENCL returns:<br>Group=1 Frame=0000001<br>101= 0.0052 102= .0086 103= -0.0015 104= 0.0017 105= -0.0162 106= 0.0035<br>107= 0.0036 108= 0.0114 109= 0.0031 110= 0.0073 111= 0.0111 112= -0.0035<br>113= 0.0057 114= 0.0097 115= 0.0049 116= 0.0086 |
| Notes       | 1. Only channels that are listed with the LIST SGN command are returned. The field length is not fixed. Scan Groups are returned as they are ready.   |

**SET**

|             |  |
|-------------|--|
| Command     | SET  |
| Syntax      | SET <name> <value><CR>   |
| Arguments   | <name> -the configuration variable to be set or modified<br><value> -the value to be assigned to that configuration variable   |
| Description | Commands the ENCL to set one of the Configuration Variables. When Configuration Variables are listed with the LIST command, the variables are output in the format required by the SET command. This enables the user to upload the data from a file that has been created by a LIST download.   |
| Returns     | <nl> -end of line  |
| Example     | This command will change configuration variable settings.<br>To set zero correction on type: SET ZC 1<CR><br><br>To change the pressure units to Pascals type: SET UNITSCAN PA<CR><br><br>To change the scan channels in Scan Group 1 from module 2, channels 1 through 16, to module 1, channels 1 through 16 type:<br>SET CHAN1 0<CR><br>SET CHAN1 1-1..1-16<CR> |

**SHUTDOWN**

|             |  |
|-------------|--|
| Command     | SHUTDOWN   |
| Syntax      | SHUTDOWN<CR>   |
| Arguments   | None   |
| Description | This command is a place holder for the system. The SHUTDOWN command is only valid in legacy ENCLs. The DSAENCL4000 will ignore this command. |
| Returns     | None   |

**SLOTS**

|             |   |
|-------------|---|
| Command     | SLOTS   |
| Syntax      | SLOTS <channel><CR>   |
| Arguments   | <channel> -The channel in module-port format  |
| Description | Queries the ENCL to return the 10 boundary pressures for the 9 pressure slots defined for a given channel.  |
| Returns     | <pre> Press 9 &lt;pressure&gt; &lt;nl&gt; Press 8 &lt;pressure&gt; &lt;nl&gt; Press 7 &lt;pressure&gt; &lt;nl&gt; Press 6 &lt;pressure&gt; &lt;nl&gt; Press 5 &lt;pressure&gt; &lt;nl&gt; Press 4 &lt;pressure&gt; &lt;nl&gt; Press 3 &lt;pressure&gt; &lt;nl&gt; Press 2 &lt;pressure&gt; &lt;nl&gt; Press 1 &lt;pressure&gt; &lt;nl&gt; Press 0 &lt;pressure&gt; &lt;nl&gt;                     </pre>  |
| Example     | <p>To determine the boundary pressures for channel 1 of the 5 psi module s/n 253<br/> Type: SLOTS 253-1&lt;CR&gt;<br/> The ENCL will return:</p> <pre> Press 9 6.10000 Press 8 4.88000 Press 7 3.66000 Press 6 2.44000 Press 5 1.22000 Press 4 0.00000 Press 3 -1.52500 Press 2 -3.05000 Press 1 -4.57500 Press 0 -6.10000                     </pre> <p>The pressures applied during a calibration must be selected so that there are not two or more applied pressures in any one slot. The module in the example above has been set up with 4 negative points. By default, it will have 4 positive points as a calibration must always include a zero point.</p> <p>In this example, the slots for channel 1 of a 15 psi module in input 2 is configured for 2 negative points<br/> Type SLOTS 2-1&lt;CR&gt;<br/> The ENCL will return:</p> <pre> Press 9 15.00000 Press 8 12.85714 Press 7 10.71429 Press 6 8.57143 Press 5 6.42857 Press 4 4.28572 Press 3 2.14286 Press 2 0.00000 Press 1 -7.50000 Press 0 -15.00000                     </pre> |
| Notes       | None  |

**STATUS**

|             |   |
|-------------|---|
| Command     | STATUS  |
| Syntax      | STATUS<CR>  |
| Arguments   | None  |
| Description | Commands the ENCL to return the current status.   |
| Returns     | <p>STATUS: &lt;current status&gt;&lt;nl&gt;<br/>           Current status: one of the following:<br/>           READY -The enclosure is ready to accept any command.<br/>           SCAN -The enclosure is in the SCAN mode. The only commands that will be accepted are STATUS or STOP.<br/>           CALZ -The enclosure is executing a CALIBRATE ZERO command. The only commands that will be accepted are STATUS or STOP.<br/>           IDPWRITE -The enclosure is writing to the ID chip.The only commands that will be accepted are IDP-CONFIRM and STOP. No other commands will be accepted.<br/>           INVALID -The command entered is not a valid command for the current mode of operation.<br/>           FDISK -The enclosure is re-formatting the Micro SD Card.<br/>           SAVE -The enclosure is saving the application configuration variables and MPF files.<br/>           SAVEIP -The enclosure is saving the Boot Loader IP configuration variables.<br/>           PURGE -The enclosure is in the PURGE mode<br/>           nl -end of line.</p> |
| Example     | <p>The STATUS command may be entered at any time. This is one of the commands that will not generate an error if entered while the ENCL is not READY. If the STATUS command is entered while the ENCL is on, but inactive, the ENCL will return:<br/>           STATUS: READY<br/>           If the STATUS command is entered while the ENCL is executing a Calibrate Zero command, the ENCL will return:<br/>           STATUS: CALZ</p>   |
| Notes       | None  |

**STOP**

|             |  |
|-------------|--|
| Command     | STOP   |
| Syntax      | STOP<CR>   |
| Arguments   | None   |
| Description | Commands the ENCL to abort the current operation and return to the READY mode. This command may be entered as STOP<CR> or by entering the Escape Key |
| Returns     | <nl> -End of line  |
| Example     | To abort any function or operation type: STOP<CR>  |
| Notes       | None   |



**TEMPERATURE**

|             |   |
|-------------|---|
| Command     | TEMPERATURE   |
| Syntax      | TEMP <type><CR>   |
| Arguments   | <p>&lt;type&gt; - May be one of the following:</p> <p>RAW -Returns the temperature in raw counts.</p> <p>EU -Returns the temperature in Engineering Units</p> <p>DEBUG -Returns the temperature update tick. If this count is increasing, it indicates that the back-ground is updating the temperature.</p> <p>UP -Returns the module temperature counts, the module temperature in °C, and the gain and offset values used for the temperature conversion.</p> <p>CTP -Returns the current temperature plane information.</p>   |
| Description | Lists the current temperatures of all 8 modules. If a module is not connected, the returned temperature will be a 0.  |
| Returns     | <p>TEMP: 1 &lt;temp&gt; &lt;nl&gt;</p> <p>TEMP: 2 &lt;temp&gt; &lt;nl&gt;</p> <p>:::</p> <p>TEMP: 8 &lt;temp&gt; &lt;nl&gt;</p> <p>&lt;temp&gt; - The module temperature in raw counts or engineering units</p> <p>&lt;nl&gt; End of line.</p>  |
| Example     | <p>To view the current temperatures of the modules connected to the ENCL type: TEMP EU&lt;CR&gt;</p> <p>The ENCL will return:</p> <p>TEMP: 1 28.75</p> <p>TEMP: 2 29.25</p> <p>TEMP: 3 30.00</p> <p>TEMP: 4 29.50</p> <p>TEMP: 5 28.25</p> <p>TEMP: 6 29.50</p> <p>TEMP: 7 28.50</p> <p>TEMP: 8 27.50</p> <p>To view the A/D counts of the temperature inputs type: TEMP RAW&lt;CR&gt;</p> <p>The ENCL will return:</p> <p>TEMP: 1 9731</p> <p>TEMP: 2 9748</p> <p>TEMP: 3 9783</p> <p>TEMP: 4 9767</p> <p>TEMP: 5 9708</p> <p>TEMP: 6 9759</p> <p>TEMP: 7 9723</p> <p>TEMP: 8 9693</p> |
| Notes       | A counts reading of 32767 indicates an open input. A counts reading of 0 with an engineering unit reading of 0 indicates that the module is not enabled.  |

**TEMPERATURE GRADIENT COMPENSATION**

|             |  |
|-------------|--|
| Command     | TEMPERATURE GRADIENT COMPENSATION  |
| Syntax      | TGRAD<CR>  |
| Arguments   | None   |
| Description | This command reads the temperature of the A/D modules and stores this information in a table. This table is then used to estimate the A/D module temperatures during a scan based on the temperature of the ENCL.  |
| Returns     | <Location> <ENCL Temp> <A/D Temp> <Delta Temp> <nl><br><Location> -A/D Location, 1 through 8<br><ENCL Temp> -Measured Temperature of the ENCL in °C<br><A/D Temp> -Measured Temperature of the ENCL A/D Module in this location.<br><Delta Temp> -The calculated Temperature differential for the A/D Module in this location.<br><nl> -End of line. |
| Example     | A ENCL has two A/D modules installed. To calculate and store the temperature differential for these modules, Type:<br>TGRAD<CR><br>The ENCL software will calculate the differential temperatures and return:<br>Loc 1 Base 33.187500 Temp 28.562500 Delta -4.625000<br>Loc 2 Base 33.187500 Temp 27.750000 Delta -5.437500                          |
| Notes       | The ENCL software can only read the temperature of the ENCL when in the scan mode. The temperature of the A/D modules connected to the ENCL can be estimated based on the gradient calculation derived from the table generated by this command.   |

**TIME AVAILABILITY TEST**

|             |  |
|-------------|--|
| Command     | TIME AVAILABILITY TEST   |
| Syntax      | TIME<CR>   |
| Arguments   | None   |
| Description | This command test the Network Time Protocol(NTP) Server specified in the IPNTP configuration variable. If a time can be retrieved, it will be returned. If the time server cannot be found, an error is returned.  |
| Returns     | The Time, if The Time Server can be found, or an Error, if the Time Server cannot be found.<br>Time in the format: YYYYMMDD_HHMMSS<br>Where: YYYY is the year<br>MM is the month ( 1 to 12)<br>DD is the day (1 to 7)<br>HH is the hour in 24 hour format<br>MM is the minute<br>SS is the seconds<br>Error -The message:<br>ERROR: Time Server cannot be found<br><n> - End of line.  |
| Example     | None   |
| Notes       | The TIME function is enabled by the setting of ENNTP in the NAS Group. ENNTP must be set to 1 to enable TIME. The time will be derived from either the NAS device or a NTP server. This will be determined by the setting of GW in the IP Group and ENNTP in the NAS Group. If a valid NTP IP address is set for GW, the time will be derived from the NTP server at that address. If the address set in GW is not available, or an invalid NTP server address, an error will be returned:<br>ERROR: Time Server cannot be found<br>If the address set in GW is the default setting, the date and time will be derived from an attached NAS device. If a NAS is not attached, an ERROR will be generated:<br>Could not get date and time |

**VERSION**

|             |  |
|-------------|--|
| Command     | VERSION  |
| Syntax      | VER<CR>  |
| Arguments   | None   |
| Description | Requests the version number of the DSAENCL4000.hex file.   |
| Returns     | VERSION: <Version string> <n><br><Version string> -The version of the .hex file  |
| Example     | To determine the version of DSAENCL4000.hex software in use type:<br>VER<CR><br>The ENCL will return:<br>VERSION: 5.10 |
| Notes       | None   |

**WRITE ID CHIP VARIABLES**

|             |   |
|-------------|---|
| Command     | WRITE ID CHIP VARIABLES   |
| Syntax      | IDPWRITE <address> <site> <device> <mtype><CR>  |
| Arguments   | <p>&lt;address&gt; -The location of the device. Valid values are 0 through 8, Where 0 can only be the Temperature A/D.</p> <p>&lt;site&gt; -A for an A/D, or M for a Module</p> <p>&lt;device&gt; -The memory device in the A/D or module. This must always be E for EPROM. The software will select the Device family based on the Name to be modified.</p> <p>&lt;mtype&gt; -E for EPROM, or P for PROM. Data stored in PROM may only be set once. If PROM data are set at the Scanivalve Factory, they may not be modified in the field. Data stored in EPROM may be modified by a user.</p>   |
| Description | The ID Chip write process requires two commands to complete. The IDPWRITE command stages the ID chip identification variables and prepares the software to write to the ID Chip PROM or EPROM. This command does not actually perform the write. The write process does not occur until a IDPCONFIRM command is issued. The IDPCONFIRM command is considered to be part of the IDPWRITE command   |
| Returns     | <p>SET IDP &lt;address&gt; &lt;site&gt; &lt;device&gt; &lt;mtype&gt; &lt;name&gt; &lt;value&gt;</p> <p>&lt;address&gt; -The location of the device. Valid values are 0 through 8, Where 0 can only be the ENCL Temperature A/D.</p> <p>&lt;site&gt; -A for an A/D, or M for a Module</p> <p>&lt;device&gt; -The memory device in the A/D or module. This must always be E for EPROM. The software will select the Device family based on the Name to be modified.</p> <p>&lt;mtype&gt; -E for EPROM, or P for PROM. Data stored in PROM may only be set once. If PROM data are set at the Scanivalve Factory, they may not be modified in the field. Data stored in EPROM may be modified by a user.</p> <p>&lt;name&gt; -The name of the variable</p> <p>&lt;value&gt; -The value of the variable</p>  |
| Example     | <p>The IDP variables for the EPROM in a ZOC module have been programmed using the SET IDP Variable commands. When all of the variables have been set, the ENCL software must be set up to write to the EPROM. The following command is entered:</p> <pre>IDPWRITE 1 M E E</pre> <p>The ENCL returns the following:</p> <pre>SET IDP 1 M E E RTYPE 0 SET IDP 1 M E E RVALUE 1 SET IDP 1 M E E RCORA 0.000000 SET IDP 1 M E E RCORB 0.000000 SET IDP 1 M E E RCDATE 1/26/2004 SET IDP 1 M E E PCDATE 1/1/2000 SET IDP 1 M E E NPR1 1.000000 SET IDP 1 M E E NPR2 1.000000 SET IDP 1 M E E VALVE 2 SET IDP 1 M E E XDUCER 0</pre> <p>Type IDPCONFIRM to confirm IDP write or STOP to escape</p> <p>If the data is correct, issue the IDPCONFIRM command to write the variables to the EEPROM. If the data are not correct, type STOP and repeat the process to correct the errors.</p> |
| Notes       | None  |

**ZERO**

|             |   |
|-------------|---|
| Command     | ZERO  |
| Syntax      | ZERO<CR>  |
| Arguments   | None  |
| Description | Lists the active zero correction values that obtained from a CALIBRATE ZERO command. These data are used in the conversion of raw counts to engineering units (EU). These values may only be set by executing a CALIBRATE ZERO.   |
| Returns     | ZERO: <channel> <value> <n><br>ZERO: <channel> <value> <n><br>:::<br>ZERO: <channel> <value> <n><br><channel> -the channel in module-port or serial number-port format<br><value> -the zero correction values<br><n> -end of line.  |
| Example     | To view the current zeros for module 1 type: ZERO 1<CR><br>The ENCL will return:<br>ZERO: 1-1 160<br>ZERO: 1-2 165<br>ZERO: 1-3 68<br>ZERO: 1-4 131<br>ZERO: 1-5 41<br>ZERO: 1-6 162<br>ZERO: 1-7 145<br>ZERO: 1-8 233<br>ZERO: 1-9 158<br>ZERO: 1-10 150<br>ZERO: 1-11 156<br>ZERO: 1-12 96<br>ZERO: 1-13 19<br>ZERO: 1-14 134<br>ZERO: 1-15 132<br>ZERO: 1-16 238 |
| Notes       | None  |

**CONFIGURATION VARIABLES**

Configuration Variables control the way the DSAENCL4000 functions. The variables are assigned to one of several groups: SCAN (GROUP S), CONVERSION (GROUP C), DIGITAL OUTPUT CONFIGURATION (GROUP D), SCAN GROUP CONFIGURATION (GROUP SG1), MODULE CONFIGURATION VARIABLES (M1 through M8), MODULE PROFILE (GROUP P), IDENTIFICATION (GROUP I), BOOT LOADER CONFIGURATION (GROUP IP), NETWORK ATTACHED STORAGE (GROUP NAS), ID CHIP CONFIGURATION (GROUP ID), TEMPERATURE OFFSET (GROUP O), and TEMPERATURE GAIN (GROUP G). Each variable is assigned a “data type” description.

**SCAN VARIABLES (GROUP S)****ADTRIG**

|               |  |
|---------------|--|
| Variable      | ADTRIG <code>  |
| Valid Values  | 0 or 1   |
| Default Value | 0  |
| Data Type     | Integer  |
| Group         | Scan Variables (List S)  |
| Description   | This variable determines the method for a Frame Trigger.<br>0 -Frame timing is controlled by an internal timer set by PERIOD.<br>1 -Frame timing is controlled by an external hardware or a software trigger. When ADTRIG is enabled, a frame will be triggered whenever a hardware or software trigger input is received. The hardware trigger is a hard wired input to the power input connector. The Software trigger is a TAB, or Ctrl I, character. When a SCAN command is received, the ENCL enters a WAIT state until a trigger pulse is received. At that time, the ENCL will acquire and output one averaged frame of data and re-enter the WAIT state. This will continue until a STOP command is received or the FPS variable is satisfied. Multiple trigger pulses received during a scan will be ignored. |

**SCANTRIG**

|               |   |
|---------------|---|
| Variable      | SCANTRIG <code>   |
| Valid Values  | 0 or 1  |
| Default Value | 0   |
| Data Type     | Integer   |
| Group         | Scan Variable (List S)  |
| Description   | This variable is a currently a non-operational variable.<br><br>This variable enables or disables external scan triggering. |

**BINADDR**

|               |   |
|---------------|---|
| Variable      | BINADDR <port> <IP address>   |
| Valid Values  | port -0 to 65535<br>IP address -any valid IP address  |
| Default Value | port -0<br>IP address -0.0.0.0  |
| Data Type     | Integer   |
| Group         | Scan Variables (List S)   |
| Description   | When port is set to 0, data are NOT sent out over the binary address port, data is sent over the standard TCP port. If port is to 65535, data are sent over that port to the IP address identified in a UDP format. |

**FM**

|              |  |
|--------------|--|
| Variable     | FM <code>  |
| Valid Values | 1  |
| Group        | Scan Variables (List S)  |
| Description  | Not used in the DSAENCL4000. This variable is a non-operational variable. It is for legacy use only. |

**IFC**

|               |   |
|---------------|---|
| Variable      | IFC <char 1> <char 2>   |
| Valid Values  | char 1 - Any valid ASCII character code<br>char 2 - Any valid ASCII character code<br><br>Set using the Decimal code for the ASCII character i.e., 62 is ">", 59 is ";" and 10 is "LF (line feed)"  |
| Default Value | char 1- 62<br>char 2- 0   |
| Data Type     | Integer   |
| Group         | Scan Variable (List S)  |
| Description   | This variable sets the interframe characters to be used when transmitting ASCII unformatted output. If only one character is desired, char 2 must be set to 0. If both characters are set to 0, no interframe characters will be transmitted. |

**PERIOD**

|               |   |
|---------------|---|
| Variable      | Period <period>   |
| Valid Values  | 10 to 4294967295  |
| Default Value | 500   |
| Data Type     | Integer   |
| Group         | Scan Variable (List S)  |
| Description   | This master period variable sets the sample rate, in microseconds, of the pressure A/D converters and the one temperature A/D converter. Period is the dwell time between channels. Period is only one of the terms required to determine data rate. Data rate is determined by the equation:<br><br>$\text{Data Rate} = \frac{1}{(\text{Period}) \times (\text{Number of Channels}) \times (\text{AVG})}$<br>Data Rate is expressed in Hertz (samples per second per channel)<br>Period is in microseconds, Channels is always 64 in a standard ENCL, AVG is the average term for that scan group. |
| Notes         | When PTP is enabled (PTPEN 1 or 2), the lowest valid value becomes 50.  |
| Notes         | When using an internal scan rate (ADTRIG 0 and PTPEN 0), the lowest value that can be used is 25 (for reliable data).   |

**QPKTS**

|              |  |
|--------------|--|
| Variable     | QPKTS <enable>   |
| Valid Values | 1  |
| Group        | Scan Variable (List S)   |
| Description  | Not used in the DSAENCL4000. This variable is a non-operational variable. It is for legacy use only. |

**TEMPPOLL**

|               |  |
|---------------|--|
| Variable      | TEMPPOLL<code>   |
| Valid Values  | 0 or 1   |
| Default Value | 1  |
| Data Type     | Integer  |
| Group         | Scan Variable (List S)   |
| Description   | This variable controls the Temperature Polling function. When this variable is enabled, the temperature of the A/D modules are read at a 5 second period.<br>0 - Temperature polling is disabled.<br>1 - Temperature polling is enabled. |

**TIMESTAMP**

|               |  |
|---------------|--|
| Variable      | TIMESTAMP<code>  |
| Valid Values  | 0 or 1   |
| Default Value | 1  |
| Data Type     | Integer  |
| Group         | Scan Variable (List S)   |
| Description   | The relative timestamp that is included in each frame of data. When set to 0, the time stamp is in microseconds. When set to 1, the time stamp is in microseconds. |
| Note          | The timestamp is only output in the binary packet.   |
| Note          | The timestamp variable does not change the format of the PTP Timestamp when BIN == 3   |
| Note          | When BIN is 1, 2, or 4, the first frame of data (index 0) will have a timestamp of 0.  |



**CONVERSION VARIABLES (GROUP C)**

**ZC**

|               |   |
|---------------|---|
| Variable      | ZC <code>   |
| Valid Values  | 0 or 1  |
| Default Value | 1   |
| Data Type     | Integer   |
| Group         | Conversion Variable (List C)                              |
| Description   | Enables or disables zero correction of the pressure data. |

**A2DCOR**

|               |   |
|---------------|---|
| Variable      | A2DCOR<code>  |
| Valid Values  | 0 or 1  |
| Default Value | 1   |
| Data Type     | Integer   |
| Group         | Conversion Variable (List C)  |
| Description   | Sets the A/D Correction ON or OFF.<br>0 -Sets the A/D correction OFF<br>1 -Sets the A/D correction ON |
| Note          | When A2DCOR is set to 0, the background processing of the A/D correction is terminated.               |

**BIN**

|               |  |
|---------------|--|
| Variable      | BIN<code>  |
| Valid Values  | 0 through 4  |
| Default Value | 0  |
| Data Type     | Integer  |
| Group         | Conversion Variable (List C)   |
| Description   | Sets the format of the output data:<br>0 - Output is in ASCII<br>1 - Output is in binary format ( <i>table 1/2</i> )<br>2 - Output is in module-port format ( <i>table 1/3</i> )<br>3 - Output is in binary format using PTP Timestamps ( <i>table 5</i> )<br>4 - Output is in binary format with a scan header ( <i>table 1/2/4</i> ) |
| Note          | The DSAENCL4000 does not support multiple scan groups. When BIN is set to 4, the value of FPS, AVG and Number of channels for scan groups 2 through 8 will be 0. If NTP is not enabled, date and time will be zeros. Please refer to the description of GW, ENNTP, and ENNAS for more information.                                     |

**CALAVG**

|               |  |
|---------------|--|
| Variable      | CALAVG <sample average>  |
| Valid Values  | 2 to 256   |
| Default Value | 32   |
| Data Type     | Integer  |
| Group         | Conversion Variable (List C)   |
| Description   | Sets the calibration sample average. This value should be set to ensure that a sufficient number of samples will be acquired to ensure a stable, noise-free calibration. |

**CALPER**

|               |   |
|---------------|---|
| Variable      | CALPER <period>   |
| Valid Values  | 500   |
| Default Value | 500   |
| Data Type     | Integer   |
| Group         | Conversion Variable   |
| Description   | Not used in the DSAENCL4000. This variable is a non-operational variable. It is for legacy use only. CALPER is set internally to the same value as PERIOD when PERIOD is set to values equal to or less than 500 microseconds. When PERIOD is set to values greater than 500 microseconds, CALPER will be set to 500. |

**CALZDLY**

|               |  |
|---------------|--|
| Variable      | CALZDLY <delay>  |
| Valid Values  | 5 to 128   |
| Default Value | 5  |
| Data Type     | Integer  |
| Group         | Conversion Variable (List C)   |
| Description   | Sets the delay time, in seconds, before the ENCL executes a CALZ command. This value should be set to ensure that a sufficient delay exists so that the ZERO Offset data are not biased by residual pressure in the module calibration valves. |

**CVTUNIT**

|               |  |
|---------------|--|
| Variable      | CVTUNIT <value>  |
| Valid Values  | Any real number  |
| Default Value | 1.0  |
| Data Type     | Float  |
| Group         | Conversion Variable (List C)   |
| Description   | This is the conversion factor to convert from PSI units to the desired scanning units. This value may be set directly or by setting the UNITSCAN variable. |

**EU**

|               |  |
|---------------|--|
| Variable      | EU <code>  |
| Valid Values  | 0 or 1   |
| Default Value | 1  |
| Data Type     | Integer  |
| Group         | Conversion Variable (List C)   |
| Description   | Sets the units of the output data:<br>0 - Output is in raw counts (analog-to-digital counts)<br>1 - Output is in selected engineering units, set by UNITSCAN   |
| Notes         | When the A/D counts reach 32767 or -32768, and EU is set to 1, the ENCL will output the values set in MAXEU and MINEU to indicate that a conversion error may exist. The ENCL will also output these values when the maximum or minimum master conversion planes are exceeded. |

**FILLONE**

|               |   |
|---------------|---|
| Variable      | FILLONE <code>  |
| Valid Values  | 0 or 1  |
| Default Value | 0   |
| Data Type     | Integer   |
| Group         | Conversion Variable (List C)  |
| Description   | Sets the type of fill that will be performed.<br>0 The pressure conversion planes will be filled using several Master Planes<br>1 The pressure conversion planes will be filled using a single Master Plane |
| Notes         | This command is disabled and is for legacy compatibility only.  |

**MAXEU**

|               |   |
|---------------|---|
| Variable      | MAXEU <value>   |
| Valid Values  | Any valid floating point number   |
| Default Value | 9999  |
| Data Type     | Floating point  |
| Group         | Conversion Variable (List C)  |
| Description   | Sets the maximum Engineering Unit value. This is the number that will be displayed when an overflow condition occurs. When the A/D counts reach 32767, and EU is set to 1, the ENCL will output 9999 or whatever has been entered as the MAXEU value to indicate that a conversion error may exist. The ENCL will also output these values when the maximum or minimum master conversion planes are exceeded. |

**MINEU**

|               |   |
|---------------|---|
| Variable      | MINEU <value>   |
| Valid Values  | Any valid floating point number   |
| Default Value | -9999   |
| Data Type     | Floating Point  |
| Group         | Conversion Variable (List C)  |
| Description   | Sets the minimum Engineering Unit Value. This is the number that will be displayed when an overflow condition occurs. When the A/D counts reach -32767, and EU is set to 1, the ENCL will output -9999 or whatever has been entered as the MINEU value to indicate that a conversion error may exist. The ENCL will also output these values when the maximum or minimum master conversion planes are exceeded. |

**STARTCALZ**

|               |  |
|---------------|--|
| Variable      | STARTCALZ <code>   |
| Valid Values  | 0 or 1   |
| Default Value | 0  |
| Data Type     | Integer  |
| Group         | Conversion Variable (List C)   |
| Description   | Not used in the DSAENCL4000. This variable is a non-operational variable. It is for legacy compatibility only. |

MPBS

|               |   |
|---------------|---|
| Variable      | MPBS <number of planes>   |
| Valid Values  | 0 to 139  |
| Default Value | 5   |
| Data Type     | Integer   |
| Group         | Conversion Variable (List C)  |
| Description   | <p>When an INSERT command is issued and a master point is overwritten, a configurable number of temperature planes on either side of the new MASTER plane are converted to calculated. These points will be recalculated when a FILL command is executed. The number of planes to be entered in this variable may be calculated by the formula:</p> <p>Planes = TEMP * 4</p> <p>where: TEMP is the number of degrees to be changed. For example, if it is desired to have points ± 4° of the new master plane modified, then MPBS would be set to 16.</p> |

**UNITSCAN**

|               |   |      |       |         |       |       |        |      |        |      |       |      |      |      |     |    |       |       |     |      |     |         |       |      |     |     |      |  |  |  |  |  |  |
|---------------|---|------|-------|---------|-------|-------|--------|------|--------|------|-------|------|------|------|-----|----|-------|-------|-----|------|-----|---------|-------|------|-----|-----|------|--|--|--|--|--|--|
| Variable      | UNITSCAN <units>  |      |       |         |       |       |        |      |        |      |       |      |      |      |     |    |       |       |     |      |     |         |       |      |     |     |      |  |  |  |  |  |  |
| Valid Values  | SEE LIST BELOW  |      |       |         |       |       |        |      |        |      |       |      |      |      |     |    |       |       |     |      |     |         |       |      |     |     |      |  |  |  |  |  |  |
| Default Value | PSI   |      |       |         |       |       |        |      |        |      |       |      |      |      |     |    |       |       |     |      |     |         |       |      |     |     |      |  |  |  |  |  |  |
| Data Type     | String  |      |       |         |       |       |        |      |        |      |       |      |      |      |     |    |       |       |     |      |     |         |       |      |     |     |      |  |  |  |  |  |  |
| Group         | Conversion Variable (List C)  |      |       |         |       |       |        |      |        |      |       |      |      |      |     |    |       |       |     |      |     |         |       |      |     |     |      |  |  |  |  |  |  |
| Description   | <p>This sets the output engineering units for the ENCL. Setting this value will also set CVTUNITS. CVTUNITS may be set to a different value, however UNITSCAN must be set first. The units supported are:</p> <table border="0"> <tr> <td>ATM</td> <td>FTH2O</td> <td>KGM2</td> <td>MH2O</td> <td>OZFT2</td> <td>BAR</td> <td>GCM2</td> <td>KIPIN2</td> </tr> <tr> <td>MMHG</td> <td>OZIN2</td> <td>CMHG</td> <td>INHG</td> <td>KNM2</td> <td>MPA</td> <td>PA</td> <td>CMH2O</td> </tr> <tr> <td>INH2O</td> <td>KPA</td> <td>NCM2</td> <td>PSF</td> <td>DECIBAR</td> <td>KGCM2</td> <td>MBAR</td> <td>NM2</td> </tr> <tr> <td>PSI</td> <td>TORR</td> <td></td> <td></td> <td></td> <td></td> <td></td> <td></td> </tr> </table> | ATM  | FTH2O | KGM2    | MH2O  | OZFT2 | BAR    | GCM2 | KIPIN2 | MMHG | OZIN2 | CMHG | INHG | KNM2 | MPA | PA | CMH2O | INH2O | KPA | NCM2 | PSF | DECIBAR | KGCM2 | MBAR | NM2 | PSI | TORR |  |  |  |  |  |  |
| ATM           | FTH2O   | KGM2 | MH2O  | OZFT2   | BAR   | GCM2  | KIPIN2 |      |        |      |       |      |      |      |     |    |       |       |     |      |     |         |       |      |     |     |      |  |  |  |  |  |  |
| MMHG          | OZIN2   | CMHG | INHG  | KNM2    | MPA   | PA    | CMH2O  |      |        |      |       |      |      |      |     |    |       |       |     |      |     |         |       |      |     |     |      |  |  |  |  |  |  |
| INH2O         | KPA   | NCM2 | PSF   | DECIBAR | KGCM2 | MBAR  | NM2    |      |        |      |       |      |      |      |     |    |       |       |     |      |     |         |       |      |     |     |      |  |  |  |  |  |  |
| PSI           | TORR  |      |       |         |       |       |        |      |        |      |       |      |      |      |     |    |       |       |     |      |     |         |       |      |     |     |      |  |  |  |  |  |  |
| Note          | If a value other than those listed is entered, The ENCL will default to PSI.  |      |       |         |       |       |        |      |        |      |       |      |      |      |     |    |       |       |     |      |     |         |       |      |     |     |      |  |  |  |  |  |  |

**DIGITAL OUTPUT CONFIGURATION VARIABLES (GROUP D)**

**DLYPG**

|               |  |
|---------------|--|
| Variable      | DLYPG <value>  |
| Valid Values  | 0 to 3600  |
| Default Value | 10   |
| Data Type     | Integer  |
| Group         | Digital Output Variables (List D)  |
| Description   | Sets the time in seconds that the module inputs will be purged. This is only a part of the total purge sequence time. This timer can be interrupted by a STOP command. When set to 0 the time is infinite and the PURGE sequence can only be terminated by a STOP command. |

**DLYPGSEQ**

|               |  |
|---------------|--|
| Variable      | DLYPGSEQ <value>   |
| Valid Values  | 0 to 60  |
| Default Value | 1  |
| Data Type     | Integer  |
| Group         | Digital Output Variables (List D)  |
| Description   | Sets the time delay in seconds before the purge air is applied to the modules. If 0 is entered, no delay will occur. |

**DOUTCALZ**

|               |  |
|---------------|--|
| Variable      | DOUTCALZ <value>   |
| Valid Values  | 0 to FF Hexadecimal  |
| Default Value | 60   |
| Data Type     | Integer  |
| Group         | Digital Output Variables (List D)  |
| Description   | Enables digital outputs for a CALZ operation. Output 1 is the least significant binary bit. Output 8 is the most significant binary bit. The command is entered as 2 hexadecimal digits. |

**DOUTPG**

|               |  |
|---------------|--|
| Variable      | DOUTPG <value>   |
| Valid Values  | 0 to FF Hexadecimal  |
| Default Value | 0  |
| Data Type     | Integer  |
| Group         | Digital Output Variables (List D)  |
| Description   | Enables digital outputs for a PURGE sequence. Output 1 is the least significant binary bit. Output 8 is the most significant binary bit. The command is entered as 2 hexadecimal digits. |

**DOUTPGSEQ**

|               |  |
|---------------|--|
| Variable      | DOUTPGSEQ <value>  |
| Valid Values  | 0 to FF hexadecimal  |
| Default Value | 0  |
| Data Type     | Integer  |
| Group         | Digital Output Variables (List D)  |
| Description   | Enables digital outputs to transition from normal operation to PURGE operation. Output 1 is the least significant binary bit. Output 8 is the most significant binary bit. The command is entered as 2 hexadecimal digits. |

**DOUTPU**

|               |   |
|---------------|---|
| Variable      | DOUTPU <value>  |
| Valid Values  | 0 to FF hexadecimal   |
| Default Value | 0   |
| Data Type     | Integer   |
| Group         | Digital Output Variables (List D)   |
| Description   | Enables the digital outputs for normal power up configuration. Output 1 is the least significant binary bit. Output 8 is the most significant binary bit. The command is entered as 2 hexadecimal digits. |

**DOUTSCAN**

|               |  |
|---------------|--|
| Variable      | DOUTSCAN <value>   |
| Valid Values  | 0 to FF hexadecimal  |
| Default Value | 4  |
| Data Type     | Integer  |
| Group         | Digital Output Variables (List D)  |
| Description   | Enables the digital outputs to indicate that the ENCL is in the SCAN mode. This variable only affects the DOUT bit that is enabled. All other outputs are masked. Output 1 is the least significant binary bit. Output 8 is the most significant binary bit. The command is entered as 2 hexadecimal digits. |

**DOUTREADY**

|               |   |
|---------------|---|
| Variable      | DOUTREADY <value>   |
| Valid Values  | 0 to FF hexadecimal   |
| Default Value | 8   |
| Data Type     | Integer   |
| Group         | Digital Output Variables (List D)   |
| Description   | Enables the digital outputs to indicate that the ENCL is in the READY mode. This variable ONLY affects the DOUT bit that is enabled. All other outputs are masked. Output 1 is the least significant binary bit. Output 8 is the most significant binary bit. The command is entered as 2 hexadecimal digits. |

**BANKA**

|               |  |
|---------------|--|
| Variable      | BANKA <value>  |
| Valid Values  | 0  |
| Default Value | 0  |
| Data Type     | Integer  |
| Group         | Digital Output Variables (List D)  |
| Description   | Not used in the DSAENCL4000. This variable is a non-operational variable. It is for legacy use only. |

**BANKB**

|               |  |
|---------------|--|
| Variable      | BANKB <value>  |
| Valid Values  | 0  |
| Default Value | 0  |
| Data Type     | Integer  |
| Group         | Digital Output Variables (List D)  |
| Description   | Not used in the DSAENCL4000. This variable is a non-operational variable. It is for legacy use only. |

**BANKUSR**

|               |  |
|---------------|--|
| Variable      | BANKUSR <value>  |
| Valid Values  | 0 to FF hexadecimal  |
| Default Value | 0  |
| Data Type     | Integer  |
| Group         | Digital Output Variables (List D)  |
| Description   | Not used in the DSAENCL4000. This variable is a non-operational variable. It is for legacy use only. |

**SCAN GROUP CONFIGURATION VARIABLES (GROUP 1 ONLY)****AVG1**

|               |  |
|---------------|--|
| Variable      | AVG1 <sample average>  |
| Valid Values  | 1 - 256  |
| Default Value | 16   |
| Data Type     | Integer  |
| Group         | Scan Group 1 (List SG1)  |
| Description   | <p>Sets the minimum number of samples to average for Scan Group 1. The average will always be to the module with the greatest number of channels. Also effects the data rate calculation:</p> $\text{Data Rate} = \frac{1}{(\text{Period}) \times (\text{Number of Channels}) \times (\text{AVG})}$ <p>Data Rate is expressed in Hertz (samples per second per channel)<br/> Period is in microseconds, Channels is always 64 in a standard ENCL, AVG is the average term for that scan group.</p> |
| Notes         | If TWOAD is set to 0, AVG must be set to 2 or more.  |

**CHAN1**

|               |  |
|---------------|--|
| Variable      | CHAN1 <channels>   |
| Valid Values  | <p>&lt;channels&gt; -Channels is a combination of a module and a port. Syntax is:</p> <p style="padding-left: 40px;">module-port; for one channel<br/> module-port, module-port; for many channels<br/> module-port..module-port; for a range of channels</p> <p>Module is the physical location of the module in the rack.<br/> Port is a single pressure sample point within a module.<br/> When 0 is entered, no channels are assigned to a scan group.</p>   |
| Default Value | 0  |
| Data Type     | String   |
| Group         | Scan Group 1 (List SG1)  |
| Description   | <p>Sets the channel assignments in scan group 1. Duplicate module-port entries are not permitted in the same module group. For example: the notation: CHAN 1-1,1-1 is not valid.</p> <p>The order of the channels in the output frame is determined by the order of entry. Use the LIST SG 1 command to verify the output frame order.</p> <p><b>Setting the channel variable does not automatically erase old channels. The user is responsible to ensure that unwanted channels are cleared before new channels are set, regardless if the same channels will be set or not. The command to clear the channel group is:</b><br/> SET CHAN1 0&lt;CR&gt;</p> |



**FPS1**

|               |   |
|---------------|---|
| Variable      | FPS1 <frames>   |
| Valid Values  | 0 to 4294967295   |
| Default Value | 0   |
| Data Type     | Long Integer  |
| Group         | Scan Group 1 (List SG1)   |
| Description   | <p>Frames per Scan. Sets the number of averaged frames for Scan Group 1 to be output after a SCAN command is issued. Data is output based on the set scan rate (see PERIOD and AVG variables).</p> <p>Averaged frames will be output until the setting of FPS is met or if a STOP command is issued. FPS can be used to control the duration of the scan. Duration can be set using the following equation:</p> $\text{FPS} = \text{Desired Length (in seconds)} \times \text{Scan Rate}$ <p>When set to 0, the scan will continue indefinitely until a stop command is received.</p> |

**SGENABLE1**

|               |  |
|---------------|--|
| Variable      | SGENABLE1 <code>   |
| Valid Values  | 1 or 0   |
| Default Value | 0  |
| Data Type     | Integer  |
| Group         | Scan Group 1 (List SG1)  |
| Description   | Not used in the DSAENCL4000. This variable is a non-operational variable. It is for legacy use only. |

**MODULE CONFIGURATION VARIABLES (M1 THROUGH M8)****ENABLE**

|               |  |
|---------------|--|
| Variable      | ENABLEn <enable> where n is the module position number 1 through 8             |
| Valid Values  | 1  |
| Default Value | 1  |
| Data Type     | Integer  |
| Group         | Module Configuration Variables   |
| Description   | This variable is not used in the DSAENCL4000. The entry is for legacy support. |

**HPRESS**

|               |  |
|---------------|--|
| Variable      | HPRESSn <ports> <pressure> where n is the module position number 1 through 8   |
| Valid Values  | <port> <pressure> - port one port<br>port,port many ports<br>port..port range of ports<br>pressure a real number representing the pressure |
| Default Value | 1..16 15.0   |
| Data Type     | String   |
| Group         | Module Configuration Variables   |
| Description   | Defines the maximum pressure for port or ports of the module n.  |

**LPRESS**

|               |  |
|---------------|--|
| Variable      | LPRESSn <ports> <pressure> where n is the module position number 1 through 8   |
| Valid Values  | <port> <pressure> - port one port<br>port,port many ports<br>port..port range of ports<br>pressure a real number representing the pressure |
| Default Value | 1..16 -15.0  |
| Data Type     | String   |
| Group         | Module Configuration Variables   |
| Description   | Defines the minimum pressure for port or ports of the module n.  |

**MODTEMP**

|               |  |
|---------------|--|
| Variable      | MODTEMPn <port number> <scale factor> where n is the module position number 1 through 8  |
| Valid Values  | <port number> -Port number- the port position to display the module temperature<br><scale factor> -Scale factor- the temperature scaling factor  |
| Default Value | 0 1.0  |
| Data Type     | String   |
| Group         | Module Configuration Variables   |
| Description   | Defines the module port number to display the module temperature and the temperature scaling factor. If EU is set to 1, the temperature output will be °C times the scale factor. If EU is set to 0, the temperature will be the displayed value divided by 4. |
| Notes         | This variable is not functional in versions 5.07 and lower.  |

**NEGPTS**

|               |  |
|---------------|--|
| Variable      | NEGPTS <sub>n</sub> <ports> <negpts> where n is the module position number 1 through 8   |
| Valid Values  | <ports> may be defined as: port -one port<br>port,port -many ports<br>port..port -a range of ports<br><negpts> -an integer that defines the number of master negative points. The maximum number of master negative points is 8. |
| Default Value | 1..16 4  |
| Data Type     | String   |
| Group         | Module Configuration Variables   |
| Description   | Defines the number of master negative points for port or ports of the module n.  |

**NPR**

|               |   |
|---------------|---|
| Variable      | NPR <sub>n</sub> <pressure> where n is the module position number 1 through 8 |
| Valid Values  | Any valid integer up to 4 digits  |
| Default Value | 15  |
| Data Type     | Integer   |
| Group         | Module Configuration Variables  |
| Description   | Defines the nominal pressure range for the module installed in position n.    |

**NUMPORTS**

|               |   |
|---------------|---|
| Variable      | NUMPORTS <sub>n</sub> <ports> where n is the module position number 1 through 8 |
| Valid Values  | 16  |
| Default Value | 16  |
| Data Type     | Integer   |
| Group         | Module Configuration Variables  |
| Description   | Defines the number of ports for the module n.                                   |
| Notes         | NUMPORTS <sub>n</sub> must be set to 16 in a ENCL                               |

**TYPE**

|               |   |
|---------------|---|
| Variable      | TYPE <sub>n</sub> <code> where n is the module position number 1 through 8  |
| Valid Values  | 0, 1, 2, 3, or 4  |
| Default Value | 0   |
| Data Type     | Integer   |
| Group         | Module Configuration Variables  |
| Description   | This Variable defines the module n type:<br>0 Standard<br>1 Absolute<br>2 Gauge<br>3 True Differential<br>4 Electrical Input Module |

***MODULE PROFILE VARIABLES (GROUP P)******ENCLSN***

|               |  |
|---------------|--|
| Variable      | ENCLSN <serial number>                     |
| Valid Values  | Any valid integer up to 4 digits           |
| Default Value | <Assigned by Scanivalve when manufactured> |
| Data Type     | Integer                                    |
| Group         | Module Profile Variables (List P)          |
| Description   | The serial number of the ENCL.             |

***SN***

|               |   |
|---------------|---|
| Variable      | SNn <serial number> where n is the module position number 1 through 8   |
| Valid Values  | Any valid integer up to 4 digits  |
| Default Value | 0   |
| Data Type     | Integer   |
| Group         | Module Profile Variables (List P)   |
| Description   | The serial number of the module installed in slot n.<br>If the module has an ID chip that can be read, these values will be populated automatically. If there is no ID or it cannot be read, this must be set manually. |
| Notes         | This variable assigns a coefficient table file (Mxxx.MPF) to the module in this position.   |

***IDENTIFICATION CONFIGURATION VARIABLES (GROUP I)***

***NL***

|               |  |
|---------------|--|
| Variable      | NL <code>  |
| Valid Values  | 0 or 1   |
| Default Value | 0  |
| Data Type     | Integer  |
| Group         | Identification Configuration Variable (List I)                                   |
| Description   | Determines the new line character(s) for all output.<br>0 - <CR><LF><br>1 - <CR> |

***ECHO***

|               |   |
|---------------|---|
| Variable      | ECHO <enable>   |
| Valid Values  | 0 or 1  |
| Default Value | 0   |
| Data Type     | Integer   |
| Group         | Identification Configuration Variable   |
| Description   | Determines if characters received from the network or the serial host will be echoed back to the host.<br>0 - Echo is disabled<br>1 - Echo is enabled |

***AUX***

|               |   |
|---------------|---|
| Variable      | AUX <comport> <BAUD> <terminator code>  |
| Valid Values  | See Below   |
| Default Value | comport -0<br>BAUD -9600<br>Terminator Code -2  |
| Data Type     | Integer   |
| Group         | Identification Configuration Variables (List I)   |
| Description   | Determines and identifies communications to External Serial Devices<br>Comport: 0 No external device connected.<br>1 An external device is connected to COM1<br>2 An external device is connected to COM2<br>BAUD: Fixed at 9600.<br>Terminator code: 0 null terminator<br>1 CR<br>2 CR LF<br>3 LF CR<br>4 LF |
| Notes         | When COM2 port is used, the NO HOST dip switch must be set. If not, the enclosure will output sign-on information to the serial device.   |

**FORMAT**

|               |   |
|---------------|---|
| Variable      | FORMAT <code>   |
| Valid Values  | 0 to 4  |
| Default Value | 0   |
| Data Type     | Integer   |
| Group         | Identification Configuration Variables (List I)   |
| Description   | <p>Determines if data is to be scrolled on the display.</p> <p>0 data are scrolled</p> <p>1 data are displayed in place, formatted for a VT100 terminal.</p> <p>2 data are output in a debug format:<br/>       &lt;frame&gt; &lt;A/D 1 m-p&gt; &lt;A/D 1 counts&gt; &lt;A/D 2 m-p&gt; &lt;A/D 2 counts&gt; &lt;eol&gt;</p> <p>3 data are scrolled in a fixed format. Five positions with no decimal . The port field is fixed at two places with a leading zero if necessary.</p> <p>4 data are output on a single line in the format:<br/>       m_cc_ee_00000_11111_22222_33333_44444_55555_66666_77777_88888_99999_aaaaa_bbbbb_ccccc_dddd_eeee_ffff&lt;eol&gt;</p> <p>Where: - is a space<br/>       m is a module from 1 to 8<br/>       cc is the start channel from 01 to 16<br/>       ee is the end channel from 01 to 16<br/>       00000 through ffff are the data formatted with no decimal point and always 5 positions wide with leading zeros.<br/>       &lt;eol&gt; is the end of line: CR, LF or CRLF based on the setting of the NL variable</p> <p>Implementation:<br/>       If more or less than 16 channels were entered as a channel list, those channels would be output all on the same line. When two or more modules are entered in the channel list, only the first would be output in the “m” position. The user must ensure that only 16 channels are entered and that those channels are all in one module. No error checking will occur.</p> |

**AUXSCHED**

|               |  |
|---------------|--|
| Variable      | AUXSCHED <enabled> <command> <internal interval time>  |
| Valid Values  | See Below  |
| Default Value | Enabled -0<br>Command -RP<br>Internal interval time -0   |
| Data Type     | Integer, String  |
| Group         | Identification Configuration Variables (List I)  |
| Description   | <p>When enabled, identifies the command to be sent to the external serial device when an ADTrig is received. The internal interval time is in milliseconds.</p> <p>&lt;enabled&gt;      0 AUXSCHED is not enabled.<br/>                        1 AUXSCHED is enabled</p> <p>&lt;command&gt;      Any valid command.</p> <p>&lt;Internal interval time&gt;      The valid range is 0 or 500 to 100,000 milliseconds. When this time is set to 0, the command will be output immediately with an external trigger. For this function to operate correctly, ADTRIG must also be set to 1.</p> |

**CAL**

|               |  |
|---------------|--|
| Variable      | CAL <comport> <BAUD>   |
| Valid Values  | See Below  |
| Default Value | Comport -0<br>BAUD -9600   |
| Data Type     | Integer  |
| Group         | Identification Configuration Variables (List I)  |
| Description   | Determines and identifies communications to Serial Calibrators<br>Comport      0 No Calibrator is connected.<br>1 A Calibrator is connected to COM1<br>2 A Calibrator is connected to COM2<br>BAUD          Fixed at 9600. |
| Notes         | When COMPORT 2 is used, the NO HOST dip switch must be set. If not, the enclosure will output sign-on information to the serial device.  |

**CALSCHED**

|               |  |
|---------------|--|
| Variable      | CALSCHED <enabled> <command> <internal interval time>  |
| Valid Values  | See Below  |
| Default Value | Enabled -0<br>Command -RP<br>Internal Interval Time -0   |
| Data Type     | Integer, String  |
| Group         | Identification Configuration Variables (List I)  |
| Description   | When enabled, identifies the command to be sent to the serial calibrator(s) when an ADTrig is received. The internal interval time is in milliseconds<br>enabled                                      0 CALSCHED is not enabled.<br>1 CALSCHED is enabled<br>command                                      Any valid calibrator command.<br>Internal interval time                      The valid range is 0 or 500 to 100,000 milliseconds<br>When this time is set to 0, the command will be output immediately with an external trigger. For this function to operate correctly, ADTRIG must also be set to 1. |

**CONOUT**

|               |  |
|---------------|--|
| Variable      | CONOUT <code>  |
| Valid Values  | 2  |
| Default Value | 2  |
| Data Type     | Integer  |
| Group         | Identification Configuration Variables (List I)  |
| Description   | Not used in the DSAENCL4000. This variable is a non-operational variable. It is for legacy use only. |

**HAVENET**

|               |                |
|---------------|----------------|
| Variable      | HAVENET <code> |
| Valid Values  | 1              |
| Default Value | 1              |
| Data Type     | Integer        |

|             |  |
|-------------|--|
| Variable    | HAVENET <code>   |
| Group       | Identification Configuration Variables (List I)  |
| Description | Not used in the DSAENCL4000. This variable is a non-operational variable. It is for legacy use only. |

**IFUSER**

|               |  |
|---------------|--|
| Variable      | IFUSER <code>  |
| Valid Values  | 0 or 1   |
| Default Value | 1  |
| Data Type     | Integer  |
| Group         | Identification Configuration Variable (List I)   |
| Description   | Not used in the DSAENCL4000. This variable is a non-operational variable. It is for legacy use only. |

**NETIN**

|               |  |
|---------------|--|
| Variable      | NETIN <code>   |
| Valid Values  | 1  |
| Default Value | 1  |
| Data Type     | Integer  |
| Group         | Identification Configuration Variable (List I)   |
| Description   | Not used in the DSAENCL4000. This variable is a non-operational variable. It is for legacy use only. |

**NETOUT**

|               |  |
|---------------|--|
| Variable      | NETOUT <code>  |
| Valid Values  | 2  |
| Default Value | 2  |
| Data Type     | Integer  |
| Group         | Identification Configuration Variable (List I)   |
| Description   | Not used in the DSAENCL4000. This variable is a non-operational variable. It is for legacy use only. |

**RESCAN**

|               |  |
|---------------|--|
| Variable      | RESCAN <code>  |
| Valid Values  | 0  |
| Default Value | 0  |
| Data Type     | Integer  |
| Group         | Identification Configuration Variable (List I)   |
| Description   | Not used in the DSAENCL4000. This variable is a non-operational variable. It is for legacy use only. |

**TWOAD**

|               |  |
|---------------|--|
| Variable      | TWOAD <code>   |
| Valid Values  | 1  |
| Default Value | 1  |
| Data Type     | Integer  |
| Group         | Identification Configuration Variable (List I)   |
| Description   | Not used in this software version. This variable is a non-operational variable. It is for legacy use only. |



**BOOT LOADER IP CONFIGURATION VARIABLES (GROUP IP)**

This group contains all of the network setup variables. All of these variables may be modified using the boot loader program, the serial connection, or the ethernet connection. Changes to the variables in this group do not take effect until the AC power has been cycled.

Modifications to the variables in this group may result in one or more of the following conditions:

1. Unstable network operation.
2. Problems completing FTP file transfers.
3. Enclosure operational problems

**The variables in this group are not saved when a SAVE command is issued. They may only be saved by using the SAVEIP command. Changes will not take effect until power is cycled on the DSAENCL4000.**

**IPADD**

|               |   |
|---------------|---|
| Variable      | IPADD <IP address>  |
| Valid Values  | IP address; any valid IP address                              |
| Default Value | 191.30.46.xxx where xxx is the serial number of the enclosure |
| Data Type     | Integer   |
| Group         | IP Configuration Variables (List IP)                          |
| Description   | The IP address of the module                                  |

**SUBNET**

|               |   |
|---------------|---|
| Variable      | SUBNET <Subnet Mask>  |
| Valid Values  | Subnet Mask; any valid Subnet Mask  |
| Default Value | 255.255.0.0   |
| Data Type     | Integer   |
| Group         | IP Configuration Variables (List IP)  |
| Description   | The Subnet mask for the module. The subnet mask must be configured for the network where the enclosure will be connected. |

**MAC**

|               |   |
|---------------|---|
| Variable      | MAC <MAC Address>   |
| Valid Values  | 000.096.093.xxx.yyy.zzz   |
| Default Value | 000.096.093.046.000.xxx where xxx is the serial number of the enclosure   |
| Data Type     | Integer   |
| Group         | IP Configuration Variables (List IP)  |
| Description   | The MAC address of the module. The last three octets may be modified by a user, but it is recommended that they not be modified. The first three octets MUST NOT be modified. These octets represent a setting registered to Scanivalve Corp. |

**LOGIN**

|               |                                       |
|---------------|---------------------------------------|
| Variable      | LOGIN <User Name>                     |
| Valid Values  | User Name; any valid character string |
| Default Value | Scanivalve                            |
| Data Type     | String                                |
| Group         | IP Configuration Variables (List IP)  |
| Description   | The user name for the FTP login.      |

**PASSWORD**

|               |   |
|---------------|---|
| Variable      | PASSWORD <Password>   |
| Valid Values  | Password; any valid character string                          |
| Default Value | Scanner   |
| Data Type     | String  |
| Group         | IP Configuration Variables (List IP)                          |
| Description   | The password associated with the user name for the FTP login. |

**LOGIN1**

|               |   |
|---------------|---|
| Variable      | LOGIN1 <user name>  |
| Valid Values  | User Name; any valid character string                                       |
| Default Value | Scanivalve1   |
| Data Type     | String  |
| Group         | IP Configuration Variables (List IP)  |
| Description   | The User Name for a second FTP login. The ENCL will support two FTP logins. |

**PASSWORD1**

|               |  |
|---------------|--|
| Variable      | PASSWORD1 <Password>   |
| Valid Values  | Password; any valid character string                                 |
| Default Value | Scanner1   |
| Data Type     | String   |
| Group         | IP Configuration Variables (List IP)                                 |
| Description   | The password associated with the user name for the second FTP login. |

**ALLOWANON**

|               |   |
|---------------|---|
| Variable      | ALLOWANON <code>  |
| Valid Values  | 0 or 1  |
| Default Value | 1   |
| Data Type     | Integer   |
| Group         | IP Configuration Variables (List IP)  |
| Description   | Determines the new line character(s) for all output.<br>0 Do not allow anonymous FTP logins<br>1 Allow anonymous FTP logins |

**APP**

|               |   |
|---------------|---|
| Variable      | APP <Application>   |
| Valid Values  | Application; any valid application  |
| Default Value | Encl4000.hex  |
| Data Type     | String  |
| Group         | IP Configuration Variables (List IP)  |
| Description   | The file name of the application to run. This is the file name that is used when automatically running the application from the boot loader. It is also the file name used when using the RUN command. If this file is not found, an error is returned. |

***GW***

|               |   |
|---------------|---|
| Variable      | GW <IP address>   |
| Valid Values  | IP address; any valid IP address  |
| Default Value | 0.0.0.0   |
| Data Type     | Integer   |
| Group         | IP Configuration Variables (List IP)  |
| Description   | This IP Address will be used to access the NTP Server if the IPNTP address setting is an IP address outside the ENCL Subnet.  |
| Notes         | If a valid NTP IP address is set for GW, and ENNAS is set to 2, and ENNTP is set to 1, a file created on the NAS will get the time and date for the file from the NTP server at this address. If this address is set to the default setting, the date and time will be derived from the NAS device.<br>If access to the NTP Server at the address set in GW is blocked, or unavailable, the SCAN function will be aborted and an error will be generated. |

**NETWORK ATTACHED STORAGE CONFIGURATION VARIABLES (GROUP NAS)**

This group contains the network attached storage configuration variables. All of these variables may be modified using the boot loader program, the serial connection, or the Ethernet connection.

The variables in this group are not saved when a SAVE, or SAVEIP command is issued. They may only be saved by using the SAVENAS command.

**ENNAS**

| Variable      | ENNAS <code>   |
|---------------|--|
| Valid Values  | 0, 1, or 2   |
| Default Value | 0  |
| Data Type     | Integer  |
| Group         | NAS Configuration Variables (Group NAS)  |
| Description   | Enables data to the NAS.<br>0 - Data are not sent to the NAS<br>1 - Data are sent to the NAS. A sequence number will be used to construct the file name.<br>2 - Data are sent to the NAS. The time, gathered from Network Time Protocol (NTP), will be used to construct the file name.  |
| Examples      | <p>EXAMPLE 1<br/>If ENNAS is set to 1 and ENNTP is set to 0, or 1 a scan command will create a file on the NAS following format:<br/>&lt;filename from FILENAS&gt;_xxxx .ext<br/>where: xxxx is a sequence number from 000 to 9999. The sequence number may be reset, or set using the RESET SEQUENCE NUMBER command.<br/>ext is DAT for binary data or TXT for ASCII data</p> <p>EXAMPLE 2<br/>If ENNAS is set to 2, and ENNTP is set to 1, a scan command will create a file on the NAS with the following format:<br/>&lt;filename from FILENAS&gt;_yyyymmdd_hhmmss.ext<br/>where: yyyymmdd_hhmmss is date and time the file was created. The format is &lt;year&gt;&lt;month&gt;&lt;day&gt;_&lt;hours&gt;&lt;minutes&gt;&lt;seconds&gt;.<br/>ext is DAT for binary data or TXT for ASCII data</p> <p>EXAMPLE 3<br/>If ENNAS is set to 2, and ENNTP is set to 0, a scan command will result in an error<br/>ERROR: Could not connect to NTP Server<br/>The scan function will be aborted and the data file will not be generated.</p> |
| Notes         | The time will be derived from either the NAS device or a NTP server. This will be determined by the setting of GW in the IP Group. If a valid NTP IP address is set for GW, and ENNAS is set to 2, and ENNTP is set to 1, a file created on the NAS will get the time and date for the file from the NTP server at the address set in GW. If the address set in GW is an invalid NTP server address, or not available when a SCAN command is issued, an error will be generated:<br>ERROR: Could not connect to NTP Server<br>The scan function will be aborted and the data file will not be generated. If GW is set to default, and ENNAS is set to 2 and ENNTP is set to 1, the date and time will be derived from the NAS device.  |

**ENNTP**

|               |   |
|---------------|---|
| Variable      | ENNTP <Code>  |
| Valid Values  | 0 or 1  |
| Default Value | 0   |
| Data Type     | Integer   |
| Group         | NAS Configuration Variables (Group NAS)   |
| Description   | Enables the Network Time Protocol (NTP).<br>0 - Network Time Protocol is disabled.<br>1 - Network Time Protocol is enabled.                     |
| Notes         | If ENNTP is set to 1 and access to the NTP Server is blocked, or unavailable, an error will be generated and the SCAN function will be aborted. |

**FILENAS**

|               |   |
|---------------|---|
| Variable      | FILENAS <Filename>  |
| Valid Values  | Any valid character string  |
| Default Value | Scan  |
| Data Type     | String  |
| Group         | NAS Configuration Variables (Group NAS)   |
| Description   | Sets the data file prefix name. The file name will be completed with either a sequence number or the date and time as documented in the description of ENNAS. |

**IPNAS**

|               |   |
|---------------|---|
| Variable      | IPNAS <IP address>                      |
| Valid Values  | Any valid IP address                    |
| Default Value | 0.0.0.0                                 |
| Data Type     | Integer                                 |
| Group         | NAS Configuration Variables (Group NAS) |
| Description   | The IP address of the FTP Server.       |

**IPNTP**

|               |   |
|---------------|---|
| Variable      | IPNTP <IP Address>                      |
| Valid Values  | Any valid IP address                    |
| Default Value | 0.0.0.0                                 |
| Data Type     | Integer                                 |
| Group         | NAS Configuration Variables (Group NAS) |
| Description   | The IP Address of the NTP server.       |

**PASSNAS**

|               |   |
|---------------|---|
| Variable      | PASSNAS <Password>  |
| Valid Values  | Password; any valid character string  |
| Default Value | ScannerNas  |
| Data Type     | String  |
| Group         | NAS Configuration Variables (Group NAS)                                     |
| Description   | The password associated with the user name for the login to the FTP Server. |

**PATHNAS**

|               |  |
|---------------|--|
| Variable      | PATHNAS </Disk/Share>  |
| Valid Values  | Any valid path to the NAS disk   |
| Default Value | /disk1/share   |
| Data Type     | String   |
| Group         | NAS Configuration Variables (Group NAS)  |
| Description   | Sets the path on the NAS for the data file. This value cannot include the drive designation (i.e., C:). The FTP Server should have the data destination defined as the root directory. |

**USERNAS**

|               |   |
|---------------|---|
| Variable      | USERNAS <User Name>                             |
| Valid Values  | User Name; any valid character string           |
| Default Value | ScanivalveNas                                   |
| Data Type     | String  |
| Group         | NAS Configuration Variables (Group NAS)         |
| Description   | The user name used for login to the FTP Server. |

**UTCCOFFSET**

|               |  |
|---------------|--|
| Variable      | UTCCOFFSET <offset>                                    |
| Valid Values  | Any valid number                                       |
| Default Value | 0  |
| Data Type     | Signed Integer   |
| Group         | NAS Configuration Variables. (Group NAS)               |
| Description   | The time offset from Coordinated Universal Time (UTC). |

**ID CHIP CONFIGURATION VARIABLES (GROUP ID)**

**IDP**

|               |   |
|---------------|---|
| Variable      | IDP <loc> <site> <device> <mem> <name> <value>  |
| Valid Values  | See Below   |
| Default Value | Varies  |
| Data Type     | Integer   |
| Group         | ID Configuration Variables (Group ID)   |
| Description   | <p>Memory Device Type P (PROM) - All Family Codes - Values may not be modified by a user</p> <p>DFC Device Family Code</p> <ul style="list-style-type: none"> <li>0 = ENCL Temperature A/D Board</li> <li>1 = ENCL Pressure A/D Board</li> <li>2 = Pressure Scanner Module</li> <li>3 = ENCL Digital I/O Device</li> <li>4 = Test Fixture (BASM3200)</li> <li>5 = Voltage Scanner Module (EIM)</li> </ul> <p>DMC Device Model Code</p> <p>Family Code = 0</p> <ul style="list-style-type: none"> <li>0 = 16 Bit 100 KHz, 5V Ref.</li> </ul> <p>Family Code = 1</p> <ul style="list-style-type: none"> <li>0 = 16 Bit 100 KHz</li> </ul> <p>Family Code = 2</p> <ul style="list-style-type: none"> <li>0 = ZOC 3016</li> <li>1 = ZOC 17</li> <li>2 = ZOC 22</li> <li>3 = ZOC 23</li> <li>4 = ZOC 33</li> </ul> <p>Family Code = 3</p> <ul style="list-style-type: none"> <li>0 = Remote Digital Switch, 8 channels</li> </ul> <p>Family Code = 4</p> <ul style="list-style-type: none"> <li>0 = BASM3200</li> </ul> <p>Family Code = 5</p> <ul style="list-style-type: none"> <li>0 = ZOC16EIM</li> <li>1 = ZOCEIM16</li> <li>2 = ZOCEIM32</li> </ul> <p>SN Serial Number Number 0 – 4096</p> <p>REV Revision Letter Code A – P</p> <p>MDATE Manufacture Date MM/DD/YYYY</p> <p>Memory Device Type E (EEPROM) - Family Code 0</p> <ul style="list-style-type: none"> <li>ADCA -A/D Correction Coefficient A -The A coefficient of <math>A x^2 + Bx + C</math>.</li> <li>ADCB -A/D Correction Coefficient B -The B coefficient of <math>A x^2 + Bx + C</math>.</li> <li>ADCC -A/D Correction Coefficient C -The C coefficient of <math>A x^2 + Bx + C</math>.</li> <li>ADCD -A/D Correction Coefficient D - The D coefficient used in the Temperature correction algorithm.</li> <li>RV Reference Voltage The measured voltage reference value used in the temperature calibration.</li> <li>ACDATE- A/D Calibration Date- MM/DD/YYYY</li> <li>SN ENCL -Serial Number Number- 0 – 4096</li> <li>APPTYPE -ENCL Application Type- 0 = Standalone 1 = Enclosure</li> </ul> |

| Variable     | IDP <loc> <site> <device> <mem> <name> <value>  |
|--------------|---|
| Desc. Cont'd | <p>Memory Device Type E (EEPROM) - Family Code 1</p> <p>ADCA -A/D Correction Coefficient A The A coefficient of <math>Ax^2 + Bx + C</math>.</p> <p>ADCB -A/D Correction Coefficient B The B coefficient of <math>Ax^2 + Bx + C</math>.</p> <p>ADCC -A/D Correction Coefficient C The C coefficient of <math>Ax^2 + Bx + C</math>.</p> <p>ECC -Excitation Current Correction Actual measured excitation current (1.5 mA ideal with exact 5 V reference).</p> <p>GAIN -Gain Code 0 = 2.852 Gain (Standard)</p> <p>ACDATE -A/D Calibration Date MM/DD/YYYY</p> <p>Memory Device Type E (EEPROM) - Family Code 2</p> <p>RTYPE - RTD Type</p> <p>0 = Platinum 385</p> <p>1 = Nickel-Iron</p> <p>RVALUE - RTD Value Code</p> <p>RTD Type Code = 0</p> <p>0 = 100 Ohm</p> <p>1 = 500 Ohm</p> <p>2 = 1000 Ohm</p> <p>RTD Type Code = 1</p> <p>0 = 604 Ohm</p> <p>RCORA -RTD Correction A- A term for Callendar-Van Dusen equation.</p> <p>RCORB -RTD Correction B- B term for Callendar-Van Dusen equation.</p> <p>RCDATE -RTD Calibration Date- MM/DD/YYYY</p> <p>PCDATE -Pressure Sensor Cal Date- MM/DD/YYYY</p> <p>NPR1 -Nominal Pressure Range 1- Value must be in PSI</p> <p>NPR2 -Nominal Pressure Range 2- Value must be in PSI</p> <p>VALVE -Pressure Valve Arrangement-</p> <p>0 – No Valve</p> <p>1 – X1</p> <p>2 – X2</p> <p>3 – NPx (Normal Px Mode)</p> <p>4 – NO ( Normal Open)</p> <p>5 – IP</p> <p>XDUCER Transducer Type</p> <p>0 – Differential</p> <p>1 – Delta</p> <p>2 – Absolute</p> <p>Memory Device Type E (EEPROM) - Family Codes 3, 4, and 5</p> <p>No programmable Values</p> |



**TEMPERATURE OFFSET VARIABLES (GROUP O)**

**TEMPBN**

|               |  |
|---------------|--|
| Variable      | TEMPBn <value> where n is the module position number   |
| Valid Values  | Any real number  |
| Default Value | -192.975693  |
| Data Type     | Float  |
| Group         | Temperature Offset Variables (Group O)   |
| Description   | <p>The “B” term in the conversion equation used to convert temperature counts to °C. If a module number is not specified, all modules will be displayed. This value is for a Nickel Iron RTD(604Ω at 0°). The conversion formula is:<br/> <math>^{\circ}\text{C} = (\text{TempMxCounts}) + \text{TempB}</math></p> <p>The default values listed for gain and offset are used for most DSA3016 series modules. This value may be set if the ID chip specifies a different RTD used.</p> |

**TEMPERATURE GAIN VARIABLES (GROUP G)**

**TEMPMN**

|               |   |
|---------------|---|
| Variable      | TEMPMn <value> where n is the module position number  |
| Valid Values  | Any real number   |
| Default Value | 0.022792  |
| Data Type     | Float   |
| Group         | Temperature Gain Variables (List G)   |
| Description   | <p>The “M” term in the conversion equation used to convert temperature counts to °C. If a module number is not specified, all modules will be displayed. This value is for a Nickel Iron RTD(604Ω at 0°C). The conversion formula is:<br/> <math>^{\circ}\text{C} = (\text{TempMxCounts}) + \text{TempB}</math></p> <p>The default values listed for gain and offset are used for most DSA3016 series modules. This value may be set if the ID chip specifies a different RTD used.</p> |

**ENCL ID CHIP DATA FORMAT**

The ENCL system uses the Dallas DS2430A EEPROM chip for storing information about various system components. The information travels with the hardware, allowing the system to configure itself after power-up. The DS2430A has two memory areas; a 64 bit permanent memory that is written once during the manufacturing, and a 256 bit area that can be written multiple times. The permanent memory area will contain information necessary to identify the device in a format that is consistent over all of our device types. The 256 bit memory area will have a device dependent format.

**PERMANENT MEMORY DATA FORMAT**

The permanent memory area contains a Device Family Code, a Device Model Code, a Serial Number, a Revision Code, and a Manufacture Date.

| Permanent Memory 64 Bits |       |                    |  |
|--------------------------|-------|--------------------|--|
| Bits                     | Name  | Description        | Assigned Values  |
| 4                        | DFC   | Device Family Code | 0 = ENCL Temperature A/D Board<br>1 = ENCL Pressure A/D Board<br>2 = Pressure Scanner Module<br>3 = ENCL Digital I/O Device<br>4 = Test Fixture<br>5 = Voltage Scanner Module  |
| 4                        | DMC   | Device Model Code  | If:<br>Family Code = 0<br>0 = 16 Bit 100 kHz, 5V Ref., Gain=2.852<br>Family Code = 1<br>0 = 16 Bit 100 kHz<br>Family Code = 2<br>0 = DSA3016<br>1 = ZOC17<br>2 = ZOC22<br>3 = ZOC23<br>4 = ZOC33<br>Family Code = 3<br>0 = RDS Remote Digital Switch, 8 Channels<br>Family Code = 4<br>0 = BASM3200<br>Family Code = 5<br>0 = ZOC16EIM<br>1 = ZOCEIM16<br>2 = ZOCEIM32 |
| 12                       | SN    | Serial Number      | Binary Number 0-4096   |
| 4                        | REV   | Revision           | Letter Code A-P  |
| 16                       | MDATE | Manufacture Date   | DDDDMMMMYYYYYY<br>DDDD=Day (1-31)<br>MMMM= Month (1-12)<br>YYYYYY= Years Past 2000 (0-128)   |
| 24                       |       | Spare              |  |

**EEPROM MEMORY DATA FORMAT**

The EEPROM data format is device dependent. The five device families are listed in the following tables.

| ENCL Temperature A/D Board (Device Family = 0) EEPROM Memory 256 Bits |         |                              |   |
|---|---------|------------------------------|---|
| Bits  | Name    | Description                  | Assigned Values   |
| 32  | ADCA    | A/D Correction Coefficient A | The A coefficient of $Ax^2+Bx+C$ . 32 bit floating point coefficients.                        |
| 32  | ADCB    | A/D Correction Coefficient B | The B coefficient of $Ax^2+Bx+C$ . 32 bit floating point coefficients.                        |
| 32  | ADCC    | A/D Correction Coefficient C | The C coefficient of $Ax^2+Bx+C$ . 32 bit floating point coefficients.                        |
| 32  | RV      | Reference Voltage            | 32 bit floating point number equals measured output of voltage reference.                     |
| 16  | ACDATE  | A/D Calibration Date         | DDDDMMMMYYYYYYY<br>DDDD = Day (1-31)<br>MMMM= Month (1-12)<br>YYYYYYY= Years past 200 (0-128) |
| 12  | SN      | ENCL Serial Number           | Binary Number 0-4096  |
| 8   | APPTYPE | ENCL Application             | Integer, Binary Number 0-255<br>0 = Standalone (Default)<br>1 = Enclosure                     |
| 92  |         | Spare                        |   |

| ENCL Pressure A/D Board (Device Family = 1) EEPROM Memory 256 Bits |        |                               |   |
|--|--------|-------------------------------|---|
| Bits   | Name   | Description                   | Assigned Values   |
| 32   | ADCA   | A/D Correction Coefficient A  | The A coefficient of $Ax^2+Bx+C$ . 32 bit floating point coefficients.                        |
| 32   | ADCB   | A/D Correction Coefficient B  | The B coefficient of $Ax^2+Bx+C$ . 32 bit floating point coefficients.                        |
| 32   | ADCC   | A/D Correction Coefficient C  | The C coefficient of $Ax^2+Bx+C$ . 32 bit floating point coefficients.                        |
| 32   | ECC    | Excitation Current Correction | 32 bit floating point number equals deviation from 1.5 mA ideal with exact 5V reference.      |
| 16   | ACDATE | A/D Calibration Date          | DDDDMMMMYYYYYYY<br>DDDD = Day (1-31)<br>MMMM= Month (1-12)<br>YYYYYYY= Years past 200 (0-128) |
| 8  | GAIN   | Gain Code                     | 0= 2.852 Gain   |
| 104  |        | Spare                         |   |

| Pressure Scanner Module (Device Family=2) EEPROM Memory 256 Bits      |        |                                  |   |
|---|--------|----------------------------------|---|
| Bits  | Name   | Description                      | Assigned Values   |
| 8   | RTYPE  | RTD Type Code                    | 0 = Platinum 385      1= Nickel-Iron  |
| 8   | RVALUE | RTD Value Code                   | RTD Type Code = 0<br>0 = 100 Ω<br>1 = 500 Ω<br>2 = 1000 Ω<br>RTD Type Code = 1<br>0 = 604 Ω                   |
| 32  | RCORA  | RTD Correction A                 | A term for Callendar-Van Dusen equation. Two 32 bit floating point numbers.                                   |
| 32  | RCORB  | RTD Correction B                 | A and B terms for Callendar-Van Dusen equation. Two 32 bit floating point numbers.                            |
| 16  | RCDATE | RTD Calibration Date             | DDDDDDMMMMYYYYYYY<br>DDDDDD = Day ( 1 – 31)<br>MMMM = Month ( 1 – 12)<br>YYYYYYY = Years Past 2000 ( 0 – 128) |
| 16  | PCDATE | Pressure Sensor Calibration Date | DDDDDDMMMMYYYYYYY<br>DDDDDD = Day ( 1 – 31)<br>MMMM = Month ( 1 – 12)<br>YYYYYYY = Years Past 2000 ( 0 – 128) |
| 32  | NPR1   | Nominal Pressure Range 1         | 32 Bit Floating Point Number, units of PSI  |
| 32  | NPR2   | Nominal Pressure Range 2         | 32 Bit Floating Point Number, units of PSI  |
| 8   | VALVE  | Pressure Valve Arrangement       | 0 = None<br>1 = X1<br>2 = X2<br>3 = NPX<br>4 = NO<br>5 = IP   |
| 8   | XDUCER | Transducer Type                  | 0 = Differential      1 = Delta<br>2 = Absolute          3 = True Delta P<br>4 = EIM                          |
| 64  |        | Spare                            |   |
| DSAENCL Digital I/O Device (Device Family = 3) EEPROM Memory 256 Bits |        |                                  |   |
| Bits  | Name   | Description                      | Assigned Values   |
| 256   |        | Not Used                         |   |
| Test Fixture (Device Family = 4) EEPROM Memory 256 Bits               |        |                                  |   |
| Bits  | Name   | Description                      | Assigned Values   |
| 256   |        | Not Used                         |   |
| Voltage Scanner (Device Family = 5) EEPROM Memory 256 Bits            |        |                                  |   |
| Bits  | Name   | Description                      | Assigned Values   |
| 256   |        | Not Used                         |   |

***PTP VARIABLES (GROUP PTP)***

***ENABLE PTP***

|               |   |
|---------------|---|
| Variable      | <b>PTPEN &lt;code&gt;</b>   |
| Valid Values  | 0 = disable<br>1 = enable<br>2 = enable as master   |
| Default Value | 0   |
| Data Type     | integer   |
| Description   | Enables the precision time protocol engine in the ENCL. When PTPEN is set to 2, the ENCL will serve as a PTP master |
| Notes         | Only one unit may be set to a master. Having multiple masters on the same network may cause some to be ignored.     |

***STAT***

|               |   |
|---------------|---|
| Variable      | <b>STAT &lt;code&gt;</b>  |
| Valid Values  | 0 = disable, 1 = serial output, 2 = network output  |
| Default Value | 0   |
| Data Type     | integer   |
| Description   | Sets the destination of PTP statistical output. The statistical data is output in the following format:<br><ofm>, <msd>, <smd>, <mpd><br>ofm = Offset From Master. Time that slave and master differ in units of microseconds<br>msd = Master to Slave Delay. Filtered packet delivery time from master to slave<br>smd = Slave to Master Delay. Filtered packet delivery time from slave to master<br>mpd = Mean Path Delay. Filtered mean path delay time |

***SST***

|               |  |
|---------------|--|
| Variable      | <b>SST &lt;time&gt;</b>  |
| Valid Values  | hh:mm:ss.fff<br>Where: hh-Hours, mm-Minutes, ss-Seconds, and ffff-fractions of a second  |
| Default Value | 0:0:0.0000   |
| Data Type     | string   |
| Description   | Sets the time to start scanning as referenced to the grandmaster.<br>The DSAENCL4000 will use the current PTP time as the scan start time under two conditions:<br>1) When the PTP system is disabled via the SET PTPEN 0 command.<br>2) When the current time has not been received from the PTP server since the DSAENCL4000 was powered up. Under this condition the DSAENCL4000 time will start at Jan 1 1970, 0:00:00.000 hours, or epoch 0 time. This most likely will happen when there is no PTP server on the network. If the ENCL4000 was enabled and then disabled after receiving a time set from the PTP time server, the ENCL4000 will keep time from the last clock setting from the PTP server.<br>When these two cases are not met, the DSAENCL4000 uses the start time set via the SET SST <time> and SET SSD <date> setting in the PTP group. |
| Notes         |  |

**SSD**

|               |   |
|---------------|---|
| Variable      | <b>SSD &lt;date&gt;</b>   |
| Valid Values  | yyyy/mm/dd<br>Where: yyy-Year, mm-Month, dd-Day   |
| Default Value | 1971/1/1  |
| Data Type     | string  |
| Description   | <p>Sets the date to start scanning as referenced to the grandmaster.</p> <p>The SST and SSD must be set to a future time in order to be used. If the date is configured in the future, issue a SCAN command. The ENCL will enter SCAN mode and wait for the time received by the Grandmaster to reach this time. Once the requirements are satisfied, the ENCL will start data transfer.</p> <p>If SST and SSD are set in the past, a SCAN will collect data immediately.</p> |

**UTCOFFSET**

|               |   |
|---------------|---|
| Variable      | <b>UTCOFFSET &lt;code&gt;</b>                                     |
| Valid Values  | hh:mm:ss<br>Where: hh-Hours, mm-Minutes, ss-Seconds               |
| Default Value | 0:0:0   |
| Data Type     | string  |
| Description   | Sets the offset to be added or subtracted from the internal time. |

**DOMAIN**

|               |  |
|---------------|--|
| Variable      | <b>DOMAIN &lt;value&gt;</b>  |
| Valid Values  | 0 to 127   |
| Default Value | 0  |
| Data Type     | integer  |
| Description   | <p>Sets the PTP Domain value.</p> <p>If the domain value is to be changed, the PTP engine must be reset for changes to take effect (set PTPEN 0 and then PTPEN 1).</p> |

**PTP COMMANDS**

**GET TIME**

|             |   |
|-------------|---|
| Command     | <b>GETTIME</b>  |
| Syntax      | <b>GETTIME</b>  |
| Arguments   | None  |
| Description | Retrieves and displays the current internal time used by the ENCL. This time may be adjusted by the UTCOFFSET variable. If the ENCL is configured to be a PTP slave on a network where a Grandmaster or PTP Master is present, this time may be the sync'd PTP time. Otherwise, it will be the internal time of the ENCL. |
| Returns     | Time string in the format:<br>Current Time <YYYY/MM/DD> <hh:mm:ss.f> sec xxxxxxxxxxx ns xxxxxxxx<br><br>Where xxxxxxx xxxxxxx is the time form Epoch (1970/1/1)   |
| Example     | <b>GETTIME</b><br>Current Time 2021/9/20 12:56:26.0 sec 1632142586 ns 152675417   |

**SET TIME**

|             |  |
|-------------|--|
| Command     | <b>SETTIME</b>   |
| Syntax      | <b>SETTIME &lt;YYYY/MM/DD&gt; &lt;hh:mm:ss&gt;</b>   |
| Arguments   | None   |
| Description | Sets the internal time of the ENCL. This time may be adjusted by the UTCOFFSET variable. If the ENCL is configured to be a PTP slave on a network where a Grandmaster or PTP Master is present, this time may be the sync'd PTP time and overwritten if set. |
| Returns     | Prompt when ready for next command.  |
| Example     | <b>SETTIME 2021/9/4 15:53:00</b>   |

**GET UTC OFFSET**

|             |  |
|-------------|--|
| Command     | <b>GETUTCO</b>   |
| Syntax      | <b>GETUTCO</b>   |
| Arguments   | None   |
| Description | Retrieves and displays the current UTC Offset (from received PTP packets).   |
| Returns     | Current UTC Offset <seconds> <update> <valid><br><br>Where <seconds> is the UTC offset in seconds, <update> is the UTC updated flag, and <valid> stats whether or not the flag is valid. |
| Example     | <b>GETUTCO</b><br>Current UTC Offset 0 1 0   |

***DISPLAY PTP STATISTICS***

|             |   |
|-------------|---|
| Command     | <b>PTPSTAT</b>  |
| Syntax      | <b>PTPSTAT</b>  |
| Arguments   | None  |
| Description | Displays the accumulated PTP data in histogram form.  |
| Returns     | OFM, INTERVAL, <interval value>, <interval -6>, <interval -5>, <interval -4>, <interval -3>, <interval -2>, <interval -1>, <interval 0>, <interval 1>, <interval 2>, <interval 3>, <interval 4>, <interval 5>, <interval 6> |
| Example     | <b>PTPSTAT</b><br>OFM, INTERVAL, 100000, 114, 13, 10, 23, 21, 15, 36, 6, 12, 9, 23, 10, 129   |

***CLEAR ACCUMULATED PTP STATISTICAL DATA***

|             |   |
|-------------|---|
| Command     | <b>PTPCLEAR</b>   |
| Syntax      | <b>PTPCLEAR</b>   |
| Arguments   | None  |
| Description | Clears the accumulated data in the histogram buffers and restarts sampling. |
| Returns     | Prompt when ready for next command.   |
| Example     | <b>PTPCLEAR</b><br>PTP Histogram Cleared                                    |





This page is intentionally left blank

**SCANIVALVE DSP BOOT LOADER**

The Scanivalve DSP Boot Loader’s main function is to allow the user to easily upload the Enclosure 4000 application via FTP. The boot loader runs the FTP server. It has been tested on Fire Fox FTP and Internet Explorer drag and drop.

Any additional file transfer protocols or additional FTP client support modification will be made solely to the application.

Bootloader versions 2.02 and higher test the validity of the application. If the application is not valid (checksum errors), the bootloader will not attempt to run the application. It will open network support so a user can connect to the enclosure with a TCP/IP connection. This will allow a user to upload a valid version using the ftp function without having to change dip switch settings. The condition of the software may be tested by entering the command VER. If this command returns 5.xx, the application is running. If this command returns 2.0x, the application has not started.

**FTP**

The FTP server supports the following FTP commands prior to login:

- USER Allows the user to enter the user’s name. Anonymous is allowed.
- PASS Allows the user to enter the password.
- QUIT Disconnects from the FTP server.

The FTP server supports the following FTP commands prior to login after login:

- RETR Initiates a file transfer from the enclosure to the host.
- STOR Initiates a file transfer from the host to the enclosure.
- PASV Sets up data port so client can connect to server’s port.
- LIST Returns a directory listing of the files stored on the enclosure
- SIZE Returns the size in bytes of the file.
- DELE Deletes the file.
- NOOP No operation. Mostly used by the client as an “are you still there” command.

Only ASCII type of transfer is supported. Only passive data connection is supported. This allows data to be transferred without the server initiating a connection to the client. This could cause firewall problems.

**BOOT LOADER AND APPLICATION FILE SYSTEM**

Filenames are limited to the 8.3 format with no spaces allowed. Only one drive is supported.

No subdirectories are supported, however, if a file path is included in the file specification only the file name portion is used. The file is written in the root directory of the drive. File storage is limited to 8MB of data and is limited to 1024 files (whichever is first). The ENCL should not be used as a file storage device. Because the Enclosure does not have a time and date clock all files created by the enclosure will have a date of Aug 8, 2008.

**DIP SWITCH SETTINGS**

The processor board has 4 DIP switches that affect the operation of the software. These switches are only read at power up. Changes to the dip switches are not effective until the power is cycled.

**SW1**

When this switch is on automatically boots the application on power up.

**SW2**

When this switch is on the boot loader will run in the debug mode. Debug output is directed to the COM2 serial port.

**SW3**

When this switch is on the boot loader and application uses the COM2 serial port for communication to other devices. When this switch is off the COM2 serial port is used as host communication. COM1 is only used for device communication.

**SW4**

Not Used (spare)

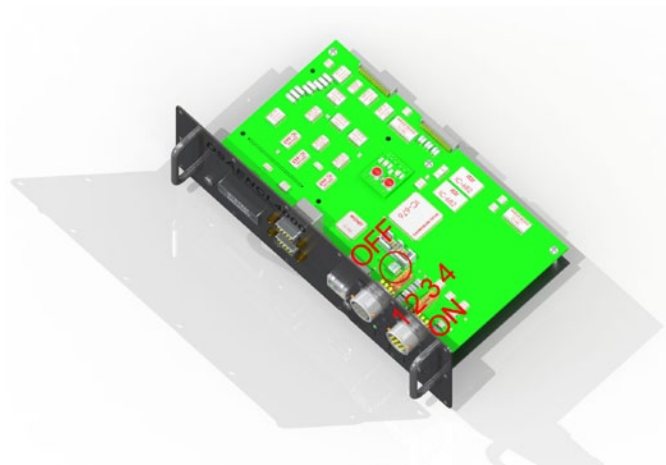

**FIGURE 5.1 - DIP SWITCH SETTINGS**

**BOOTLOADER COMMANDS**

When a command is completed the prompt character, the greater than character ">", is output preceded by a carriage return and line feed. The commands listed below are supported by the boot loader and the executable program, unless otherwise noted. They may be viewed and modified in the DSAENCL4000 executable program.

|                             |  |
|-----------------------------|--|
| VER                         | Returns the version of the Boot Loader.<br>NOTE: This command is available in the boot loader only. It must not be confused with the VER command in the application.   |
| FORMAT                      | Formats the flash memory to all 0's.<br>NOTE: This command is available in the boot loader only.   |
| LIST IP                     | Returns the configuration variable settings of the IP group.   |
| SET <parameter>             | Sets the indicated parameter.  |
| IPADD <IP Address>          | Sets the IP address of the enclosure. If IPADD is changed, the power must be cycled to take effect.  |
| SUBNET <mask>               | Sets the subnet address of the enclosure. If SUBNET is changed, the power must be cycled to take effect.   |
| MAC <MAC Address>           | Sets the MAC address for the enclosure. If MAC is changed, the power must be cycled to take effect.<br>NOTE: This variable should not be modified.   |
| LOGIN <user name>           | Sets the user name for FTP login.  |
| PASSWORD <password>         | Sets the password associated for LOGIN.  |
| LOGIN1 <user name>          | Sets the user name 1 for FTP login.  |
| PASSWORD1 <password>        | Sets the password associated for LOGIN name 1.   |
| LOGINNAS <name>             | Sets the name for login to the NAS. The boot loader does not access the NAS device. This is in this group for compatibility with the IP group in the application.  |
| PASSWORDNAS <password>      | Sets the password associated with LOGINNAS name.   |
| IPADDNAS <IP address>       | Sets the IP address of the NAS.  |
| APP <application file name> | Sets the file name of the application to run. This is the file name that is used when automatically running the application from the boot loader. It is also the file name used when using the RUN command. When this file is not found the application does not run and an error is returned. |
| SAVE [<file name>]          | Saves the configuration variables to the working directory. When an optional file name is entered, it saves the IP group settings to that file name.   |
| TYPE <file name>            | Lists the contents of the named file.  |
| LOAD <file name>            | Loads the named file into the LIST IP configuration variables.<br>NOTE: This command is a debug command.   |
| DIR                         | Lists the files on the flash memory.   |



**DSAENCL4000 DATA SELECTION CHART**

This chart shows all valid data setups for versions 5.06 and higher (PTP available with version 5.24 and higher).

| Data Destination            | Data Type   | Packet Type | TRIG | PTPEN | ENNAS | EU | BIN | FORMAT | ADTRIG | BINADDR |
|-----------------------------|-------------|-------------|------|-------|-------|----|-----|--------|--------|---------|
| FTP with Date/Time FileName | EU Pressure | BINARY      | INT  | 0     | 2     | 1  | 1   | X      | 0      | X       |
|                             |             | ASCII       | INT  | 0     | 2     | 1  | 0   | 0      | 0      | X       |
|                             |             | BINARY      | EXT  | 0     | 2     | 1  | 1   | X      | 1      | X       |
|                             |             | ASCII       | EXT  | 0     | 2     | 1  | 0   | 0      | 1      | X       |
|                             | ADC Counts  | BINARY      | INT  | 0     | 2     | 0  | 1   | X      | 0      | X       |
|                             |             | BINARY      | EXT  | 0     | 2     | 0  | 1   | X      | 1      | X       |
|                             |             | ASCII       | INT  | 0     | 2     | 0  | 0   | 0      | 0      | X       |
|                             |             | ASCII       | EXT  | 0     | 2     | 0  | 0   | 0      | 1      | X       |
| FTP Sequence FileName       | EU Pressure | BINARY      | PTP  | 1     | 1     | 1  | 3   | X      | 0      | X       |
|                             |             | BINARY      | INT  | 0     | 1     | 1  | 1   | X      | 0      | X       |
|                             |             | ASCII       | INT  | 0     | 1     | 1  | 0   | 0      | 0      | X       |
|                             |             | ASCII       | EXT  | 0     | 1     | 1  | 0   | 0      | 1      | X       |
|                             |             | BINARY      | EXT  | 0     | 1     | 1  | 1   | X      | 1      | X       |
|                             | ADC Counts  | BINARY      | PTP  | 1     | 1     | 0  | 3   | X      | 0      | X       |
|                             |             |             | INT  | 0     | 1     | 0  | 1   | X      | 0      | X       |
|                             |             |             | EXT  | 0     | 1     | 0  | 1   | X      | 1      | X       |
|                             |             | ASCII       | INT  | 0     | 1     | 0  | 0   | 0      | 0      | X       |
|                             |             |             | EXT  | 0     | 1     | 0  | 0   | 0      | 1      | X       |
| UDP                         | EU Pressure | BINARY      | PTP  | 1     | 0     | 1  | 3   | X      | 0      | >0      |
|                             |             |             | INT  | 0     | 0     | 1  | 1   | X      | 0      | >0      |
|                             |             |             | EXT  | 0     | 0     | 1  | 1   | X      | 1      | >0      |
|                             | ADC Counts  |             | PTP  | 1     | 0     | 0  | 3   | X      | 0      | >0      |
|                             |             |             | INT  | 0     | 0     | 0  | 1   | X      | 0      | >0      |
|                             |             |             | EXT  | 0     | 0     | 0  | 1   | X      | 1      | >0      |
| TCP Telnet                  | EU Pressure | ASCII       | INT  | 0     | 0     | 1  | 0   | 0      | 0      | X       |
|                             |             |             | EXT  | 0     | 0     | 1  | 0   | 1      | 1      | X       |
|                             | ADC Counts  |             | INT  | 0     | 0     | 0  | 0   | 0      | 0      | X       |
|                             |             |             | EXT  | 0     | 0     | 0  | 0   | 0      | 1      | X       |
|                             |             |             | INT  | 0     | 0     | 0  | 0   | 1      | 0      | X       |
|                             |             |             | EXT  | 0     | 0     | 0  | 0   | 1      | 1      | X       |
| TCP Binary                  | EU Pressure | BINARY      | PTP  | 1     | 0     | 1  | 3   | X      | 0      | 0       |
|                             |             |             | INT  | 0     | 0     | 1  | 1   | X      | 0      | 0       |

**NOTES FOR THE DATA SELECTION CHART**

1. An error will be issued if a combination not listed above is selected.
2. An error will be issued if NAS Date-Time is selected and a NTP server is not found (ENNTP 1).
3. The DSAENCL4000 will not SCAN in a non-valid combination.
4. An error will be issued if the channel list is empty.
5. The host computer firewall may have be set to permit the NTP, FTP, or UDP to operate correctly.

**ASCII DATA TRANSFER**

| Function Description   | Bytes  | Data Type | Value  |
|--|--------|-----------|--|
| ASCII Data (The first two bytes must NOT be 1Hex through 9Hex). Refer to the Command Section of this manual for the proper Command return formats. | Varies | String    | Unique to Packet.<br>Each line is terminated with a CR, LF, CR-LF, or LF-CR. |

EXAMPLES:

The following shows the format of the ASCII DATA portion of the List Packet in response to a LIST MASTER:

```
INSERT <temp> <chan> <press> <press counts> /M
INSERT <temp> <chan> <press> <press counts> /M
:      :      :      :
INSERT <temp> <chan> <press> <press counts> /M
```

When a LIST ALL is commanded, master and calculated planes are listed. The Master items will have a /M suffix while the calculated items will have a /C. The following is an example of a LIST ALL command:

```
INSERT <temp> <chan> <press> <press counts>/M
INSERT <temp> <chan> <press> <press counts>/C
: :      :      :
INSERT <temp> <chan> <press> <press counts>/M
```

**ASCII SCAN DATA**

When **BIN** is set to 0, ASCII pressure data is output when a **SCAN** command is issued. The format of the ASCII data output is determined by the **FORMAT** variable in **LIST I**.

When **FORMAT** is 0, the data will be in scrolling format:

```
<scan group> <frame> <channel> <pressure> <nl>
<scan group> <frame> <channel> <pressure> <nl>
:: :: :: ::
<scan group> <frame> <channel> <pressure> <nl>
```

Where:

- <scan group> - the scan group number from 1 to 8
- <frame> - the current frame number
- <channel> - the channel in module-port format
- <pressure> - the pressure in either counts or real number format based on the EU configuration variable
- <nl> - end of line

When FORMAT is 1, the data will be in a VT100 format and will constantly update:

```
Group=<scan group> Frame=<number>
<channel>= <pressure> <channel>= <pressure> <channel>= <pressure> <channel>= <pressure> <channel>= <pressure>
<channel>= <pressure> <channel>= <pressure> <channel>= <pressure> <channel>= <pressure> <channel>= <pressure>
<channel>= <pressure> <channel>= <pressure> <channel>= <pressure> <channel>= <pressure> <channel>= <pressure>
```

Where:

- <scan group> - the scan group number from 1 to 8
- <number> - the current frame number
- <channel> - the channel in module-port format
- <pressure> - the pressure in either counts or real number format based on the EU configuration variable
- <nl> - end of line

## **BINARY SCAN PACKETS**

**TABLE 1: BINARY SCAN PACKET**

When BIN equals 1, 2, or 4, this binary packet is output.

| Function Description | Bytes | Data Type            | Value  | Notes                       |
|----------------------|-------|----------------------|--|-----------------------------|
| Binary ID            | 1     | Byte                 | EU = 0x01, RAW = 0x02 ( <i>SET BIN 2 is 0x03 or 0x04</i> )   |                             |
| Group ID             | 1     | Byte                 | 1 to 8 (or 81 to 88)   |                             |
| Number of Channels   | 2     | Short                | 0 to 512   |                             |
| Frame Number         | 4     | Unsigned Integer     | 1 to 2 <sup>32</sup>   |                             |
| Time                 | 4     | Unsigned Integer     | 0 to 2 <sup>32</sup>   | Frame time in ms or $\mu$ s |
| Channel Data         |       | Struct[Num Channels] | Channel Data(c) for c = 1 to numChannels<br>See Table 2 or 3 |                             |

**TABLE 2: CHANNEL DATA**

When BIN == 1, 3, or 4, the channel data is output as follows (per channel):

| Function Description | Bytes | Data Type        | Value | Notes                       |
|----------------------|-------|------------------|-------|-----------------------------|
| Pressure             | 4     | Float or Integer |       | Float if EU, Integer if RAW |

**TABLE 3: CHANNEL DATA WITH HEADER**

When BIN == 2, the channel data is output as follows (per channel):

| Function Description | Bytes | Data Type        | Value                   | Notes                       |
|----------------------|-------|------------------|-------------------------|-----------------------------|
| Pressure             | 4     | Float or Integer |                         | Float if EU, Integer if Raw |
| Module Number        | 2     | Short            | 1 to 8                  |                             |
| Port Number          | 2     | Short            | 1 to Number of Channels |                             |



**TABLE 4: BINARY SCAN HEADER PACKET**

When BIN == 4, a binary header packet is output at the beginning of the scan only. It is only output one time.

| Function Description        | Bytes | Data Type           | Value      | Notes                                   |
|-----------------------------|-------|---------------------|------------|---|
| Header Size                 | 2     | Short               | 136        | Total header packet size in bytes (136) |
| Sample Date                 | 10    | Char                | MM/DD/YYYY | ASCII encoded date                      |
| Sample Time                 | 8     | Char                | hh:mm:ss   | ASCII encoded time                      |
| Frames Per Scan             | 32    | Unsigned Integer[8] |            | FPS(g), 4 bytes per scan group g        |
| Average                     | 16    | Short[8]            |            | AVG(g), 2 bytes per scan group g        |
| Num Channels Per Scan Group | 16    | Short[8]            |            | nChan(g), 2 bytes per scan group g      |
| Period                      | 4     | Unsigned Integer    |            |   |
| ADTRIG                      | 2     | Short               |            |   |
| A2DCOR                      | 2     | Short               |            |   |
| CVTUNITS                    | 4     | Float               |            |   |
| MAXEU                       | 4     | Float               |            |   |
| MINEU                       | 4     | Float               |            |   |
| Module SN                   | 16    | Short[8]            |            | SN(m), 2 bytes per module (m)           |
| Num Channels Per Module     | 16    | Short[8]            |            | nChan(m), 2 bytes per module (m)        |

**TABLE 5: BINARY SCAN PACKET WITH PTP TIME**

This packet is only output when BIN == 3. The PTP start and frame time will only be correct if PTPEN == 1 and the unit is synchronized with a PTP Grandmaster.

| Function Description  | Bytes | Data Type            | Value   | Notes       |
|-----------------------|-------|----------------------|---|-------------|
| Binary ID             | 1     | Byte                 | EU = 0x05, RAW = 0x06                                   |             |
| Group ID              | 1     | Byte                 | 1 to 8 (or 81 to 88)                                    |             |
| Number of Channels    | 2     | Short                | 0 to 512  |             |
| Frame Number          | 4     | Unsigned Integer     | 1 to 2 <sup>32</sup>                                    |             |
| Scan Start Time - PTP | 4     | Unsigned Integer     | 0 to 2 <sup>32</sup>                                    | Seconds     |
| Scan Start Time - PTP | 4     | Unsigned Integer     | 0 to 2 <sup>32</sup>                                    | Nanoseconds |
| Frame Time - PTP      | 4     | Unsigned Integer     | 0 to 2 <sup>32</sup>                                    | Seconds     |
| Frame Time - PTP      | 4     | Unsigned Integer     | 0 to 2 <sup>32</sup>                                    | Nanoseconds |
| Channel Data          |       | Struct[Num Channels] | Channel Data(c) for c = 1 to numChannels<br>See Table 2 |             |

# SECTION 6: MAINTENANCE

## SPECIAL PROCEDURES

This section contains the procedures to update the firmware, add calibration coefficients to the flash memory, and formatting procedures. The DSAENCL4000 should be in the READY mode while these changes are being made. This will have no effect on the operation. The procedures described in this section are written for use in a Windows operating system.

The firmware and coefficient procedures that follow may not function correctly if Windows Internet Explorer is not set up correctly. A user should verify these settings before attempting these procedures.

### INTERNET EXPLORER SETUP

1. Open Internet Explorer
2. Click on Tools
3. Select Internet Options from the drop down menu.

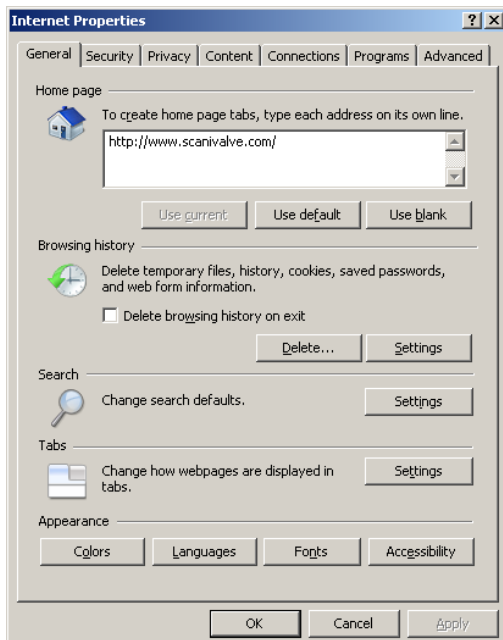

The Internet Option window will open.

4. Click on the Advanced Tab to show the Advanced Settings
5. Scroll down to the Heading marked "Browsing"
6. Make sure that the line "Enable FTP Folder View (Outside of Internet Explorer)" is checked. If this is not enabled, Internet Explorer will block FTP file transfers.

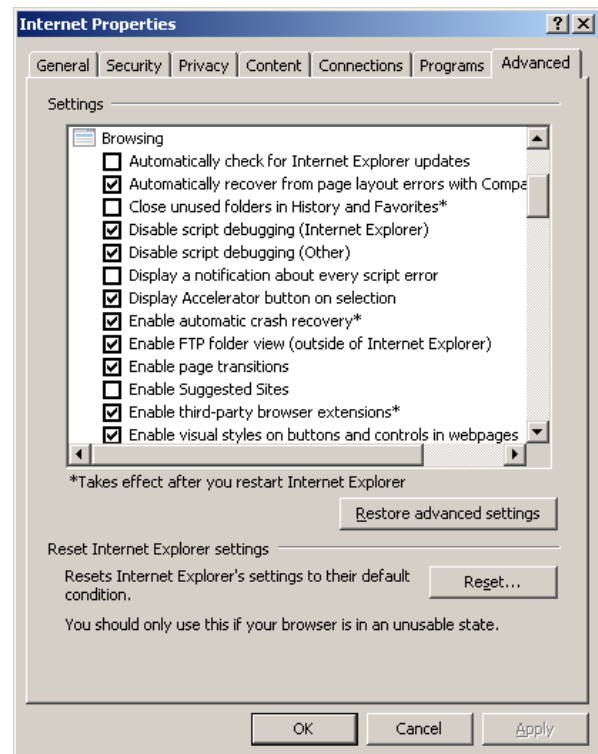

7. Click OK to Accept the settings.



7. When the copy function is complete, the DSAENCL400 window will show the new files. The time and date will show the Time and Date of the transfer. This is the only time this date will be shown. All files on the DSAENCL4000 show the same date and time after a reboot or power cycle: July 31, 2008 5:00PM.

8. Cycle the AC power or execute a Reboot command to complete the process.

### **FORMATTING FLASH MEMORY**

**WARNING:** This procedure will delete all contents in the ENCL memory, including settings, coefficient files, and the IP address of the ENCL. This should only be used if there are issues with the operation of the ENCL or if instructed by a Scanivalve representative. You must have the DSAENCL4000.HEX firmware file to perform this procedure (provided on a USB thumb drive or by Scanivalve).

This procedure can be run when connected via Ethernet (if possible) or via Serial connection. In the event that Ethernet communications are not possible, the ENCL must be forced into Bootloader mode to format the ENCL. Please refer to the Bootloader section and Dip Switch settings in the manual.

1. Connect to the modules using Ethernet or Serial, and a terminal emulator of choice (ScanTel, HyperTerminal, puTTY).

Issue the commands:

**FDISK<ENTER>**

**FDISKCONFIRM<ENTER>**

This will start the format sequence. It will take approximately 5-10 seconds for the disk to completely format.



```

ScanTel
File Disconnect Configuration Font Size Display Help

Format ended
>cat ipadd 191.30.46.171
>list ip
SET IPADD 191.30.46.171
SET SUBNET 255.255.0.0
SET MAC 0.96.93.46.0.01
SET LOGIN Scanivalve
SET PASSWORD Scanner
SET LOGINI Scanivalve
SET PASSWORD1 Scanner1
SET ALGORITHM 1
SET APP Encl4000.hex
SET GW 0.0.0.0
>saveip
WARNING: This action could cause network communication problems
Type SAVEIPCONFIRM to confirm SAVEIP or STOP to cancel
>saveipconfirm
Saving....

```

2. Save the Current IP Address. Verify the IP address is set properly by typing:  
**LIST IP <ENTER>**

If the IP address is correct, save the new IP address by sending the command:

**SAVEIP<ENTER>**

Followed by:

**SAVEIPCONFIRM<ENTER>**



```

ScanTel
File Disconnect Configuration Font Size Display Help

Format ended
>cat ipadd 191.30.46.171
>list ip
SET IPADD 191.30.46.171
SET SUBNET 255.255.0.0
SET MAC 0.96.93.46.0.01
SET LOGIN Scanivalve
SET PASSWORD Scanner
SET LOGINI Scanivalve
SET PASSWORD1 Scanner1
SET ALGORITHM 1
SET APP Encl4000.hex
SET GW 0.0.0.0
>saveip
WARNING: This action could cause network communication problems
Type SAVEIPCONFIRM to confirm SAVEIP or STOP to cancel
>saveipconfirm
Saving....

```

3. Open Windows File Explorer and create and FTP connection to the ENCL using the IP address in the last step. Copy and paste the DSAENCL4000.hex firmware file into the memory of the ENCL. Wait for the transfer to complete.

4. Power cycle the DSAENCL4000.

5. Establish an Ethernet connection using the IP address in step 2. At this point, the DSAENCL4000 will be operating completely on factory defaults with no calibration coefficients loaded. See the DSAENCL4000 Calibration Coefficient Installation in this section of the manual to load the calibration coefficients.

### **CHANGING THE IP ADDRESS**

The following procedure will change the IP address of the DSAENCL4000 using a terminal emulator (ScanTel, HyperTerminal, puTTY, etc).

1. Establish a connection to the DSAENCL4000 using a serial or Ethernet connection and appropriate software. For initial connection information, please see Section 3: Operation.

2. Issue the command:

**LIST IP<ENTER>**

The IP address variable and value will be displayed.

3. Issue the command:

**SET IPADDR xxx.xxx.xxx.xxx<ENTER>**

(where **xxx.xxx.xxx.xxx** is the IP address desired)

4. Issue the command:

**LIST IP<ENTER>**

Confirm that the IP address set is correct.

5. Issue the commands:

**SAVEIP<ENTER>**

**SAVEIPCONFIRM<ENTER>**

The IP address has now been saved.

6. Issue the command:

**REBOOT<ENTER>**

or cycle the ENCL power

The ENCL will now boot with the newly set IP address.

**SPECIAL HARDWARE**

**HARD DISK DRIVE**

The Hard Disk Drive used in the DSAENCL4000 is a Micro SD Card. It has a capacity of 2 Gbytes. It may be removed by the user for data security. Access is through the access panel on the rear of the enclosure. Beginning with serial number 226, the Micro SD Card was replaced with an onboard flash chip. The Micro SD Card is not used on these units.

**COOLING FAN**

The cooling fan is a Mechatronics F4010H05. The power requirements are 5 Vdc @ 100ma. It rotates at 4200 rpm and provides an air flow of 4.6 scfm. The fan must not be obstructed. The EMI mesh should be cleaned occasionally in order to keep the cooling air flow at a maximum.

**NOTE: The DSAENCL4000 MUST be shut down as soon as possible if the cooling fan is not operating.**

Continued operation of the DSAENCL4000 without sufficient cooling air will result in damage to the Microprocessor.

**DSAENCL4000 ASSEMBLY DETAILS**

The DSAENCL4000 is built from subassemblies. Many of these subassemblies are shared with other variations of the DSAENCL4000 family. All of the subassemblies are field replaceable if caution is taken. The image below shows the major subassemblies.

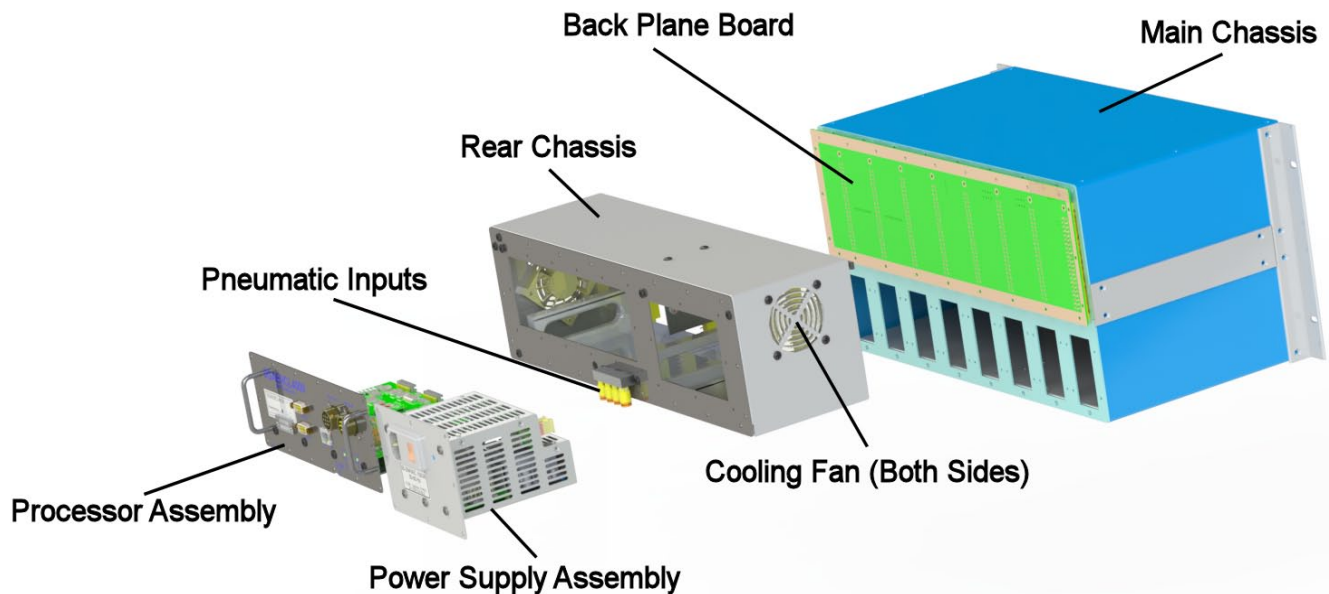

This page is intentionally left blank

# APPENDIX

## APPENDIX A - TEMPERATURE COMPENSATED PRESSURE CONVERSION

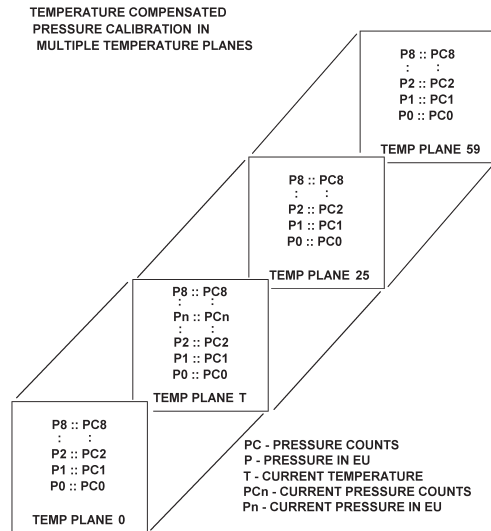

**Formulas:**

Pressure interpolation within current temperature plane:

$$P_{nt} = \frac{1}{PC_{1t} - PC_{0t}} ((PC_{1t} - PC_{nt})P_{0t} - (PC_{0t} - PC_{nt})P_{1t})$$

Calculation of entries in current temperature plane:

$$P_t = \frac{1}{T_{25} - T_0} ((T_{25} - T)P_{00} - (T_0 - T)P_{025})$$

**APPENDIX B - ENGINEERING UNIT CONVERSION CONSTANTS**

| UNITSCAN Setting | Engineering Unit               | PSI to EU<br>1 psi=          | EU to PSI<br>1 EU= |
|------------------|--------------------------------|------------------------------|--------------------|
| ATM              | Atmospheres                    | 0.068046 A                   | 14.6960 psi        |
| BAR              | Bars                           | 0.068947 b                   | 14.5039 psi        |
| CMHG             | Centimeter of Mercury          | 5.17149 cmHg                 | 0.193368 psi       |
| CMH2O            | Centimeter of Water            | 70.308 cmH <sub>2</sub> O    | 0.014223 psi       |
| DECIBAR          | Decibar                        | 0.68947 db                   | 1.4504 psi         |
| FTH2O            | Foot of water                  | 2.3067 ftH <sub>2</sub> O    | 0.43352 psi        |
| GCM2             | Gram per square Centimeter     | 70.306 g/cm <sup>2</sup>     | 0.014223 psi       |
| INHG             | Inch of Mercury at 0°C         | 2.0360 inHg                  | 0.491159 psi       |
| INH2O            | Inch of Water at 4°C           | 27.680 inH <sub>2</sub> O    | 0.036127 psi       |
| KGCM2            | Kilogram per square Centimeter | 0.0703070 kg/cm <sup>2</sup> | 14.2235 psi        |
| KGM2             | Kilogram per square Meter      | 703.070 kg/m <sup>2</sup>    | 0.0014223 psi      |
| KIPIN2           | kips per square inch(ksi)      | 0.001 kip/in <sup>2</sup>    | 1000.0 psi         |
| KNM2             | Kilonewton per square Meter    | 6.89476 kN/m <sup>2</sup>    | 0.145038 psi       |
| KPA              | Kilopascal                     | 6.89476 kPa                  | 0.145038 psi       |
| MBAR             | Millibar                       | 68.947 mb                    | 0.014504 psi       |
| MH2O             | Meter of Water                 | 0.70309 mH <sub>2</sub> O    | 1.42229 psi        |
| MMHG             | Millimeter of Mercury          | 51.7149 mmHg                 | 0.0193368 psi      |
| MPA              | Megapascal                     | 0.00689476 MPa               | 145.038 psi        |
| NCM2             | Newton per square Centimeter   | 0.689476 N/cm <sup>2</sup>   | 1.45038 psi        |
| NM2              | Newton per square Meter        | 6894.76 N/m <sup>2</sup>     | 0.000145038 psi    |
| OZFT2            | Ounce per square Foot          | 2304.00 oz/ft <sup>2</sup>   | 0.000434028 psi    |
| OZIN2            | Ounce per square Inch          | 16.00 in/ft <sup>2</sup>     | 0.062500 psi       |
| PA               | Pascal                         | 6894.76 Pa                   | 0.000145038 psi    |
| PSF              | Pound per square Foot          | 144.00 lb/ft <sup>2</sup>    | 0.00694444 psi     |
| TORR             | Torr                           | 51.7149 T                    | 0.0193368 psi      |



## **APPENDIX C - SOFTWARE REVISION LIST**

Version 1.00 to 1.02 - Not Released

Version 1.03 - Released September 2009

Initial Release

Version 1.04 - Released December 2009

Added support of A2DCAL

Set the Serial Port - COM2 - as a data destination

Removed NOID support

Added stop SCAN to TCP connect and disconnect

UDP port range extended from 0 to 65535

Corrected a bug in the DELETE command

Corrected a bug in the TYPE command

Added SAVE to the STATUS command

Added RESTART command

Version 1.05 - Released December 2009

Corrected a bug in the PURGE and CALZ timers

Increased the maximum value of PERIOD to 4294967295

Adjusted CALPER settings. CALPER will be set by the software to the value of PERIOD if PERIOD is equal to or less than 500 microseconds. When PERIOD is set to values greater than 500

microseconds, CALPER will be set to 500 microseconds.

Version 1.06 and 1.07 - Not released

Version 1.08 - Released February 2010

Corrected a major bug in the File Management system that prevented the software from recognizing files past a deleted file. Any enclosure with a version older than this version must be upgraded.

Corrected a bug in the Serial mode that did not return a carriage return after an escape character was used to stop a scan.

Corrected a bug that caused the software to not indicate -9999 when a negative full scale value was exceeded.

Corrected a minor bug in the handling of ID and non ID enabled modules.

Corrected a bug that enabled DOUT 4 at all times.

Activated TGRAD

Corrected minor bugs in IDP commands

Version 5.00 - Released March 2010

Modified the Ethernet connection so a second connection will override an existing connection.

Changed version number to 5.00 to differentiate it from other Enclosure Software versions.

Version 5.01 - Released March 2010

Corrected a bug in the UDP Port assignment

Corrected problems in AUXSCHED and CALSCHED.

Version 5.02 - Released June 2010

Changed default setting of SGENABLE1 to 0

Changed default setting of PERIOD to 500

Changed default setting of CALZDLY to 5

Changed default setting of AVG1 to 16

Changed default setting of BINADDR to 0 0.0.0.0

Changed default setting of CALAVG to 32

Version 5.03 - Released July 2010

Improved ASCII data transmission

Added another format type for a special PLC application

Documented the DISCONNECT command

Version 5.04 - Released August 2010

Resolved an issue where disconnecting while scanning could lead to future disconnects not functioning properly.

Removed CR-LF from CALCMD and AUXCMD response to match legacy enclosures.

Changed scan header to nothing is outputted when with a 0 length channel list.

Updated to only allow AUX and CAL commands if ADTRIG is set to 1.

Updated Wiznet configuration when setting SET BINADDR is commanded.

Version 5.05 - Released December 2010

Added another format to the FORMAT variable - named Format 4 - this is similar to Format 3.

Corrected a bug in the MPBS calculation.

Corrected a bug that would sometimes cause the software to use the address set in IPADDNAS as the IPADD address. This would prevent an FTP connection.

Corrected a bug in the REMn comments assignments

Corrected a bug in the A/D temperature calculations

Version 5.06 - Released January 2011

Added a binary scan header to the binary output when BIN is set to 4

Added binary raw data packet type 02.

Added support of TCP/IP Binary data output

Added NAS support, including NAS variables in Group NAS

Removed the following variables from the IP Group:

LOGINNAS

PASSWORDNAS

IPADDNAS

Added NTP functions including TIME command to test the NTP.

Added "robust" testing of data destinations with error messages when a configuration is invalid.

Added a table "DSAENCL4000 Data Selection Chart" to the software documentation.

Fixed a bug that caused an occasional NULL character (0) to be sent out with ASCII data.

Version 5.07 - Released February 2011

Added support for CREATESPf

Added support for MERGESPF

Added the command BLVER to show the version of the bootloader

Increased the FTP receive time out to 28 seconds

Corrected a bug in the timing of the serial prompt

Changed the MAC address storage from Hexadecimal to decimal to conform with our other software.

Version 5.08 - Released April 2011

Improved the ASCII data transfer rate

Improved the External Trigger function

Version 5.09 - Released May 2011

Increased the Binary TCP/IP output buffer size.

Added support of Binary packets Type 3 and 4

Version 5.10 - Released September 2011

Added SHUTDOWN command as a placeholder

Version 5.11 - Released January 2012

Version 5.12 - Released January 2012

Resolved a bug when using CALSCHED or AUXSCHED with an external trigger.

Version 5.13 - Released February 2012

Added support for up to 22 temperature plane calibration coefficients from 10 planes.

Version 5.14 - Released June 2012

Increased the ID chip programming dwell time from 3.2ms to 10ms.

Version 5.15 - Released July 2015

Resolved a bug allowing duplicate INSERT entries at 0 temperature points. Changed low limit compare from greater than to greater than or equal to.

Version 5.16 - Released August 2015

Resolved a bug that did not allow proper saving of A/D coefficients to the EEPROM.

Version 5.20 - Released March 2016

Updated firmware to support new flash chip memory. This version is backwards compatible and will work in older hardware versions. First unit to ship with V5.20 is SN: 226.

Version 5.21 - Released September 2017

Resolved a bug that loaded the incorrect ZERO/DELTA on startup.

Version 5.22 - Released February 2019

Corrected an addressing issue with external triggering.

Version 5.23 - Released March 2019

Improved ID Chip programming reliability.

Version 5.24 - Not Released

Version 5.25 - Released September 2021

Added IEEE1588-2008v2 Precision Time Protocol compatibility, variables and commands required for PTP Master-Slave operation. Added binary packet to support PTP timestamps. Fixed the standard micro and millisecond time stamps when not using PTP. Added binary buffer to improve FTP/TCP data transfer quality. This version is backwards compatible with hardware that does not support PTP.

Version 5.26 - Released December 2021

Fixed issue that output extra frame of data in ASCII format when AVG > 1.

Version 5.27 - Released February 2025

Added PTP Domain value to LIST PTP. Fixed an issue with MODTEMP not being enabled. Fixed TCP Binary data output issue that was caused in version 5.20. Support for Z.MPF files. ID Chip additions for future products. Changed default values of TEMP M and B.

This page is intentionally left blank

## **Scanivalve**

*1722 N. MADSON ST.  
LIBERTY LAKE, WA 99019*

*PHONE: 1-800-935-5151  
1-509-891-9970  
FAX: 1-509-891-9481*

*SCANCO@SCANIVALVE.COM  
WWW.SCANIVALVE.COM*

*DSAENCL4000 HARDWARE & SOFTWARE MANUAL  
FEBRUARY 10, 2025*