

NOTES:

1. ALL DIMENSIONS IN INCHES.
2. MATERIAL: 304 OR 321 SS, DEPENDENT ON TUBE SIZE.
3. STANDARD LENGTHS AVAILABLE. CUSTOM LENGTHS CAN BE ORDERED BUT WILL REQUIRE SETUP CHARGES.
4. RoHS 3 COMPLIANT.

REVISIONS

REV	DESCRIPTION	DATE	APPROVED
-	INITIAL RELEASE	6-25-20	RP
A	RESOLVE CLERICAL ERRORS	11-5-20	RP

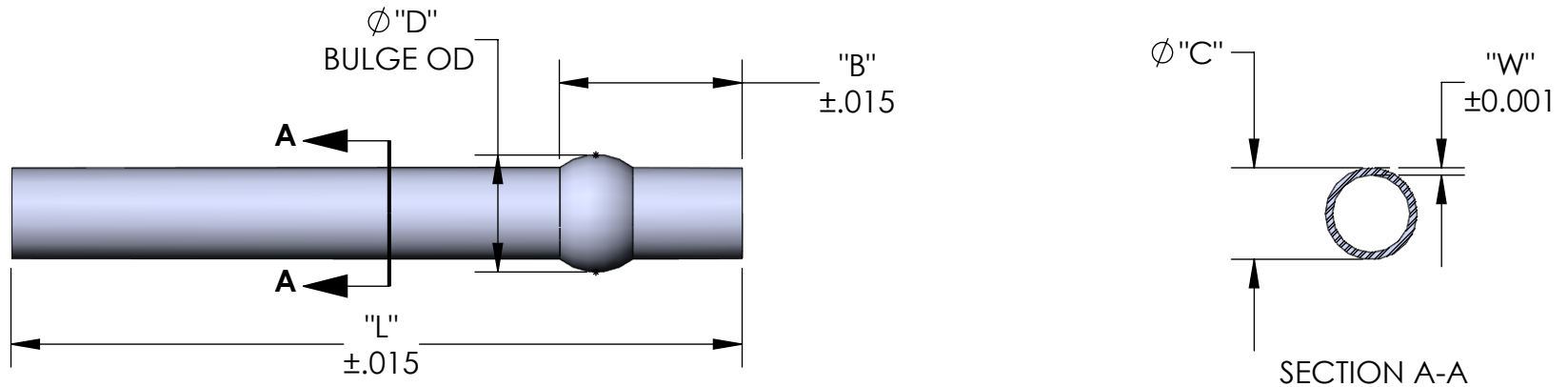

ORDERING INFORMATION

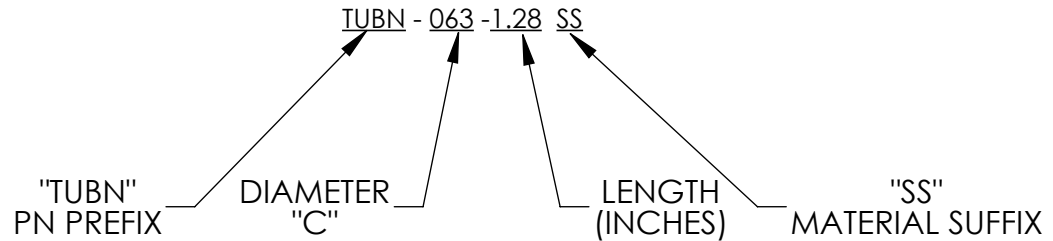

DASN NO.	OD "C"	WALL "W"	ID	"B"	BULGE OD "D"
-040	0.042 ±.001	0.006	0.030	0.100	0.047 ±.001
-063	0.0625 ±.001	0.010	0.0425	0.150	0.070 ±.002
-083	0.083 ±.001	0.010	0.063	0.200	0.090 ±.002
-093	0.093 ±.001	0.010	0.073	0.200	0.101 ±.002
-125	0.125 ±.001	0.010	0.105	0.250	0.1425 ±.003
-187	0.1875 ±.001	0.016	0.1555	0.350	0.2125 ±.003
-250	0.250 ±.001	0.016	0.218	0.300	0.295 ±.005

UNLESS OTHERWISE SPECIFIED:

DIMENSIONS ARE IN INCHES
 TOLERANCES:
 TWO PLACE DECIMAL ± .010
 THREE PLACE DECIMAL ± .003
 SHEETMETAL PARTS ± .025
 BEND RADIUS .06 MAX
 ANGULARITY ± 1.5°

VALUED CUSTOMER:

CUSTOMER APPROVAL:

DATE

6-25-20

6-25-20

6-25-20

DATE:

CAD: SOLIDWORKS 2019

SCALE: N/A

ERO#:

SHEET 1 OF 1

Scanivalve
LIBERTY LAKE, WA

TITLE:
BULGED TUBULATION (TUBN)
SALES DRAWING

SIZE A	DWG. NO. 80158	REV A
-----------	-------------------	----------