

NOTES:

1. REFERENCE SCANIVALVE DRAWING 81077 FOR DIMENSIONAL INFORMATION.
2. TUBE "STICKOUT" IS FIXED BASED ON TUBE DIAMETER.
3. 0.040" SIZE IS THE NOMINAL DIMENSION - ACTUAL TUBE OD IS 0.042"
4. SELECT ONE OPTION FOR EACH OF THE 5 PARAMETERS.

REVISIONS

REV	DESCRIPTION	DATE	APPROVED
-	INITIAL RELEASE	7-2-20	RP
A	CLARIFY NOTES	7-2-2	RP

SIDE TUBE SIZE:

- 0.031" (NON BULGED)
- 0.040"*
- 0.063"
- 0.083"
- 0.093"
- 0.125"

NUMBER OF SIDE TUBES:

- 2 8
- 3 9
- 4 10
- 5 11
- 6 12
- 7

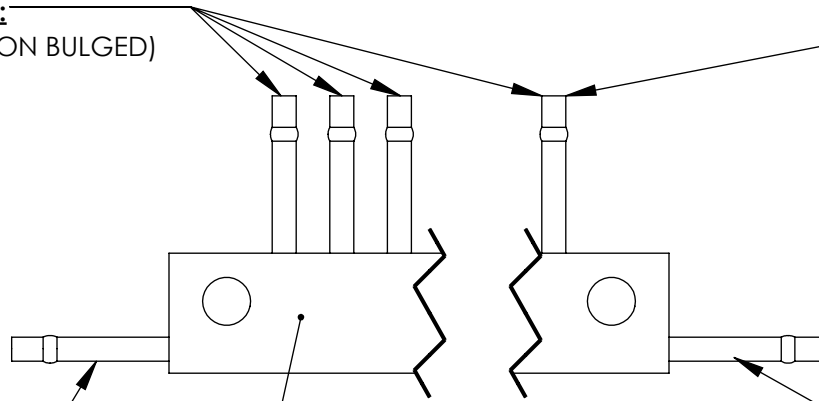

END TUBE SIZE:

- 0.031" (NON BULGED)
- 0.040"*
- 0.063"
- 0.083"
- 0.093"
- 0.125"
- NO TUBE

BODY MATERIAL:

- ANODIZED ALUMINUM (SELECT COLOR BELOW)
- BRASS (ADDITIONAL COST)

END TUBE SIZE:

- 0.031" (NON BULGED)
- 0.040"*
- 0.063"
- 0.083"
- 0.093"
- 0.125"
- NO TUBE

PART NUMBER STRUCTURE:

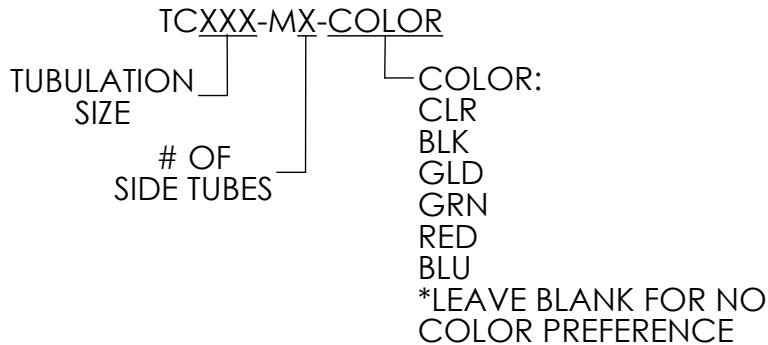

UNLESS OTHERWISE SPECIFIED:

DIMENSIONS ARE IN INCHES
 TOLERANCES:
 TWO PLACE DECIMAL ± .015
 THREE PLACE DECIMAL ± .005
 SHEETMETAL PARTS ± .025
 BEND RADIUS .06 MAX
 ANGULARITY ± 1.5°

VALUED CUSTOMER:

CUSTOMER APPROVAL:

NA

DO NOT SCALE DRAWING

	DATE	NAME
DRAWN	7-1-20	RAP
CHECKED	7-1-20	AE
ENGINEER	7-1-20	RP

DATE:

Scanivalve
 LIBERTY LAKE, WA

TITLE:

TC-M MANIFOLD
 ORDER SHEET

SIZE	DWG. NO.	REV
A	80159	A

SCALE: N/A ERO#: SHEET 1 OF 1

CAD: SOLIDWORKS 2019