

NOTES:

1. MAX PRESSURE: 500PSI
2. DIMENSIONS: INCHES
3. .125 TUBING CONNECTOR IS OPTIONAL
4. SHOWN WITH 2" RETAINER (OPTIONAL), 3" RETAINER IS STANDARD

REVISIONS

REV	DESCRIPTION	DATE	APPROVED
-	PRODUCTION RELEASE	5-25-17	SH

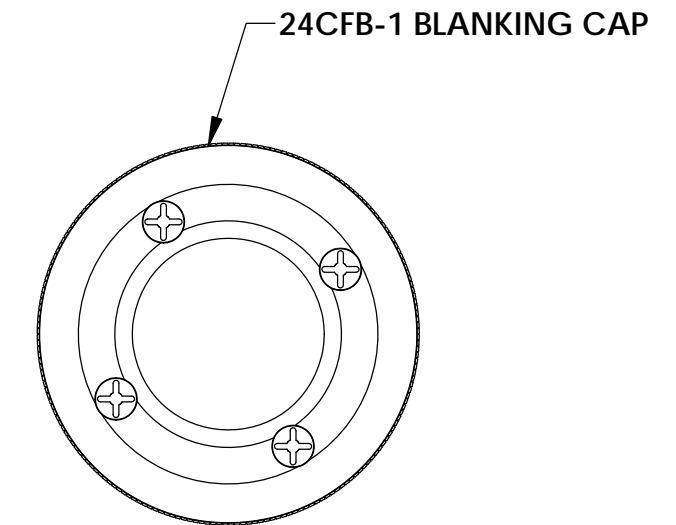
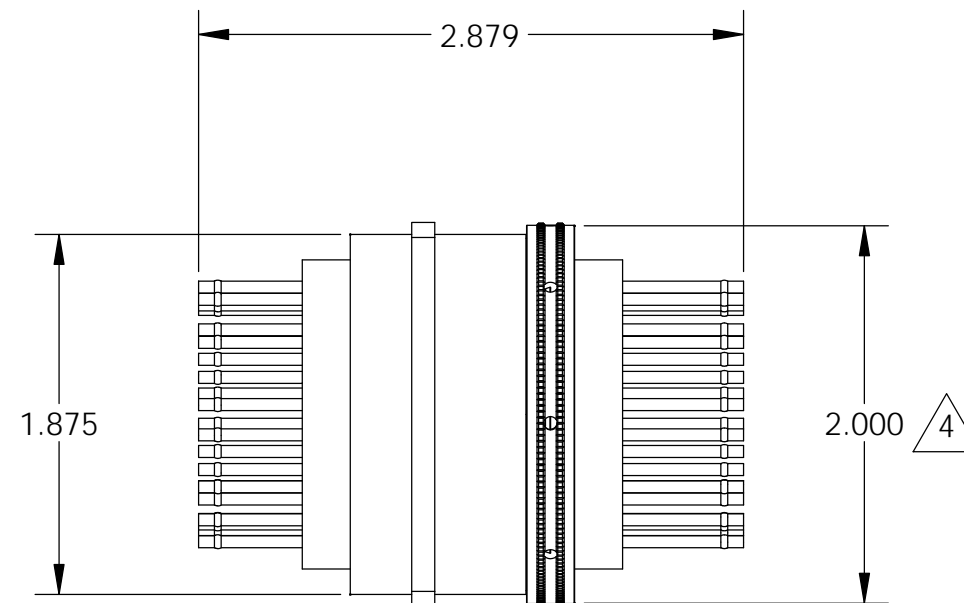
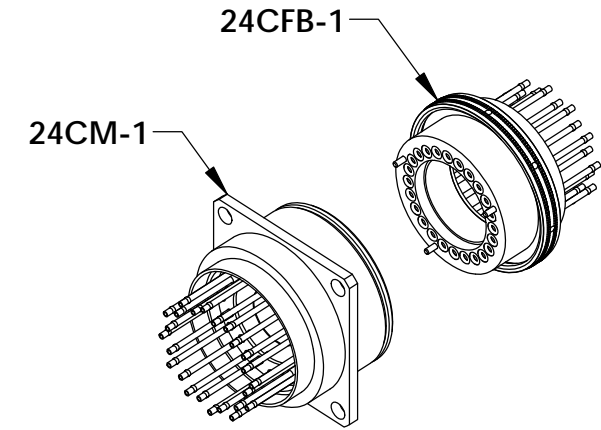
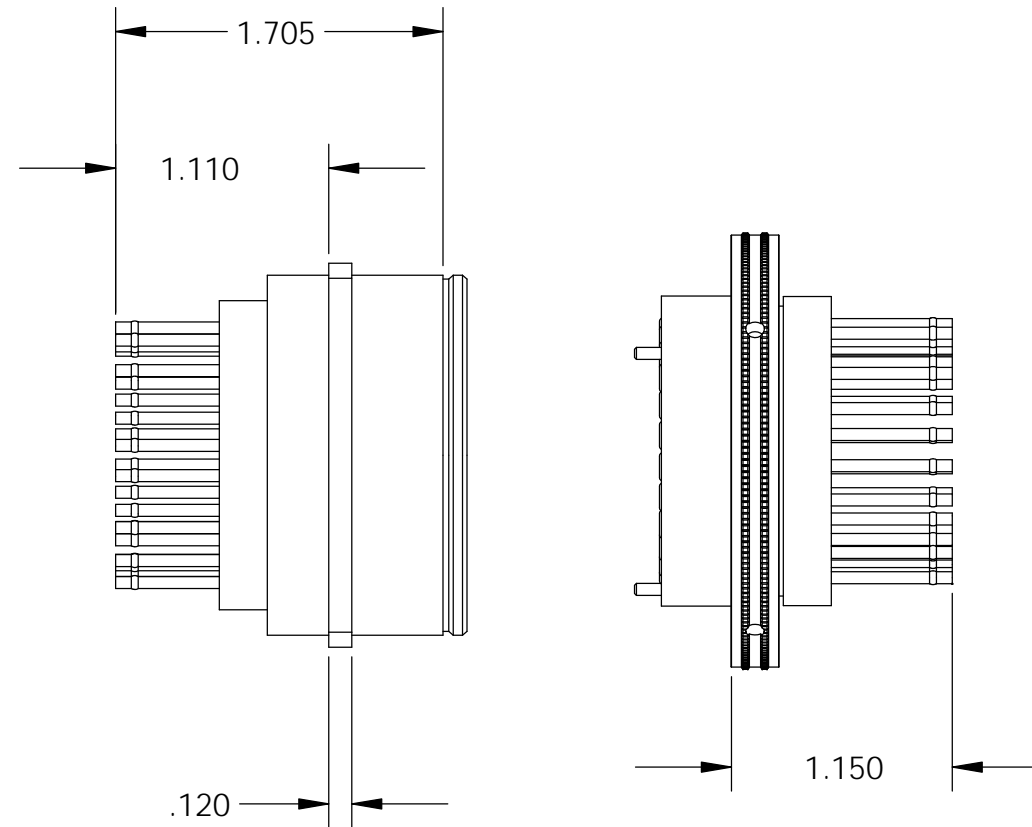
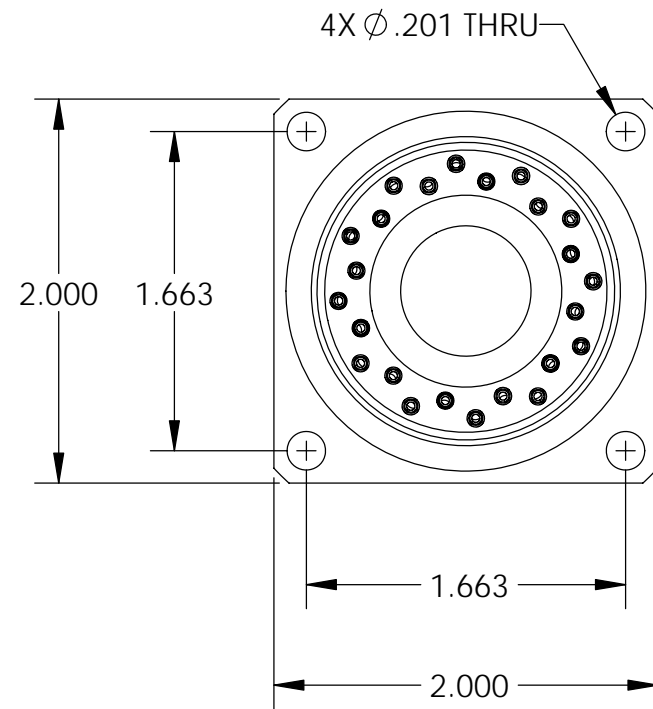

UNLESS OTHERWISE SPECIFIED: DIMENSIONS ARE IN INCHES TOLERANCES: TWO PLACE DECIMAL ±.015 THREE PLACE DECIMAL ±.005		DRAWN	5-25-17	SH	Scanivalve LIBERTY LAKE, WA TITLE: 24 PORT CONNECTOR (24CM-1 / 24CFB-1), .063 TUBE OUTLINE DRAWING
SHEETMETAL PARTS ±.010 BEND RADIUS .06 MAX ANGULARITY ±1.5°		CHECKED	5-25-17	BCB	
MATERIAL		ENGINEER	5-25-17	BCB	
FINISH		MODEL REV: C			SIZE
TOOLBOX					DWG. NO.
DO NOT SCALE DRAWING		CAD: SOLIDWORKS 2017			80190
					REV
					-
		SCALE: N/A ERO#:			SHEET 1 OF 1

-1 24 PORT CONNECTOR (24CM-1/ 24CFB-1), .063 TUBE OUTLINE DRAWING