

DTS4050/16Tx
DTS4050/32Tx
DTS4050/64Tx

THERMOCOUPLE SCANNERS

HARDWARE AND SOFTWARE MANUAL
SOFTWARE VERSION 1.02



Scanivalve

PREFACE

WARNINGS, CAUTIONS AND NOTES



The WARNING! symbol indicates that danger of injury for persons and the environment and/or considerable damage (mortal danger, danger of injury) will occur if the respective safety precautions are not taken.



The CAUTION ! symbol indicate danger for the system and material if the respective safety precautions are not taken.



The ESD note symbol indicates that proper precautions for handling Electrostatic Sensitive Devices needs to be taken when performing the related operation. This includes the use of grounded work surfaces and personal wrist straps to prevent damage to sensitive electronic components.

WARRANTY

Scanivalve Corporation, Liberty Lake, Washington, hereafter referred to as Seller, warrants to the Buyer and the first end user that its products will be free from defects in workmanship and material for a period of twelve (12) months from date of delivery. Written notice of any claimed defect must be received by Seller within thirty (30) days after such defect is first discovered. The claimed defective product must be returned by prepaid transportation to Seller within ninety (90) days after the defect is first discovered. Seller's obligations under this Warranty are limited to repairing or replacing, at its option, any product or component part thereof that is proven to be other than as herein warranted.

Surface transportation charges covering any repaired or replacement product or component part shall be at Seller's expense; however, inspection, testing and return transportation charges covering any product or component part returned and redelivered, which proves

not to be defective, shall be at the expense of Buyer or the end user, whichever has returned such product or component part.

This Warranty does not extend to any Seller product or component part thereof which has been subjected to misuse, accident or improper installation, maintenance or application; or to any product or component part thereof which has been repaired or altered outside of Seller's facilities unless authorized in writing by Seller, or unless such installation, repair or alteration is performed by Seller; or to any labor charges whatsoever, whether for removal and/or reinstallation of the defective product or component part or otherwise, except for Seller's labor charges for repair or replacement in accordance with the Warranty. Any repaired or replacement product or component part thereof provided by Seller under this Warranty shall, upon redelivery to Buyer, be warranted for the unexpired portion of the original product warranty.

THIS WARRANTY IS IN LIEU OF AND EXCLUDES ALL OTHER WARRANTIES, EXPRESS OR IMPLIED, ARISING BY

OPERATION OF LAW OR OTHERWISE, INCLUDING THE IMPLIED WARRANTIES OF MERCHANTABILITY AND FITNESS FOR A PARTICULAR PURPOSE, AND IN NO EVENT SHALL SELLER BE LIABLE FOR INCIDENTAL OR CONSEQUENTIAL DAMAGES.

In the event of a failure:

- 1) Notify Scanivalve Corporation, Customer Service Department. Include model number and serial number. On receipt of this information, service data or shipping instructions will be forwarded. This may be transacted by telephone or e-mail.
 - 2) On receipt of shipping instructions, forward the product, transportation prepaid. Repairs will be made and the product returned.
 - 3) All shipments should be made via "Best Way".
- The product should be shipped in the original packing container or wrapped in protective material and surrounded by a minimum of four (4) inches of a shock absorbing material.

TRADEMARKS ® AND COPYRIGHTS ©

Scanivalve is a registered trademark of Scanivalve Corporation.

All other brand and product names are trademarks or registered trademarks of their respective companies.

PACKAGING FOR SHIPMENT

If the product must be shipped, whether being returned to Scanivalve or relocated to another location it must be packaged properly to minimize the risk of damage. The recommended method of packing is to place the instrument in a container, surrounded on all sides with at least four inches of shock attenuating material such as Styrofoam peanuts.

IMPORTANT NOTICE

Please note that the product specifications and other information contained in this manual are subject to change without notice. Scanivalve Corporation makes an effort and strives to provide complete and current information for the proper use of the equipment. If there are any questions regarding this manual or the proper use of the equipment, contact Scanivalve Corporation.

CONTACT INFORMATION

If there are any questions or concerns regarding any Scanivalve product please do not hesitate to contact us at the following:

Scanivalve Corp.
1722 N. Madson Street
Liberty Lake, WA 99019
Telephone: (800)935-5151 (509)891-9970
Fax: (509)891-9481
scanco@scanivalve.com
www.scanivalve.com

Scanivalve Corporation is an ISO9001:2000 certified company.

TABLE OF CONTENTS

PREFACE	IV
Warnings, Cautions and Notes	iv
Warranty	iv
Trademarks ® and Copyrights ©	v
Packaging for Shipment	v
Important Notice	v
Contact Information	v
SECTION 1: SPECIFICATIONS	7
General Specifications	7
Environment Specifications	7
DTS4050/16Tx - Screw Terminal Outline Drawing	8
DTS4050/16Tx - Panel Jack Outline Drawing	9
DTS4050/32Tx - Screw Terminal Outline Drawing	10
DTS4050/32Tx - Panel Jack Outline Drawing	11
DTS4050/64Tx Outline Drawing	12
SECTION 2: INTRODUCTION	13
General Description	13
Module Configurations	13
Screw Terminal	13
Panel Mount Version	13
Heater Option	13
Environmental Considerations	13
SECTION 3: OPERATION	15
Unpack & Inventory	15
Mounting	15
Warm-up	15
Communications	15
Serial Communications	15
Ethernet Communications	16
Client/Host Options	16
PC - TCP/IP	16
PC - UDP	17
PC - ScanTel	17
PC - LabVIEW Configuration Utility	17
PC - LabVIEW Development Kit	17
PC - OPC Server	17
PC - HyperTerminal	17
Scanning	17
Scanning With An External Trigger	18
Hardware Trigger	18
Software Trigger	18

[This page intentionally left blank]

DIP Switch Settings	18
DSP Boot Loader	18
FTP	18
Boot Loader and Application File System	19
Host Communication	19
Commands	19
IEEE-1588 PTP	20
SECTION 4: HARDWARE	21
Electrical Connections	21
Ethernet Connection	21
Trigger/Config Connection	21
Power Connection	21
Thermocouple Inputs	22
Screw Terminal Connections	22
Panel Jack Connections	22
Insulation Cover (Screw Terminal)	22
Thermocouple Grounding Scenarios	23
SECTION 5: SOFTWARE	25
DTS Control and Configuration	25
TCP Telnet Server	25
UDP ID Server	25
Serial Commands	25
Data Transfer	25
DTS 4050 Command and Data Output Matrix	26
Command List	27
A/D Calibration	27
Auto Status	27
Bootloader Version	28
CLEAR	28
Close Host Binary Server Connection	28
Connect to Host Binary Server	29
Correct RTD Voltage Tables	29
Enter Channel Calibration Setpoints	30
Enter RTD Calibration Setpoints	30
Error	31
Fill	31
Get PTP Time	31
Get UTC Offset	32
Host Binary Server Command	32
Ice Point Offset Adjustment	32
List Bootloader Group Variables	33
List Calibration	33
List Channel Correction Setpoints	34
List Channel Correction Setpoints (multi-temperature calibration)	35
List Channel Definitions	35
List Configuration Variables	35
List Files	36
List Gain	36
List Identification	37

List Labels	37
List Limits	38
List Network Identification	38
List Offset	39
List Precision Time Protocol	39
List RTD Correction Values	40
List RTD Conversion Values	40
List RTD Current Conversion Values	41
List Scan Variables	41
List UTR Calibration Variables	42
Open Thermocouple Test	42
Clear Accumulated PTP Data	42
Display PTP Statistics	43
Reboot	43
Save	43
Save Bootloader Variables	44
Save PTP Variables	44
Scan	45
Scan Trigger	47
Set	47
Status	48
Stop	48
Version	48
Configuration Variables	49
Scan Variables (LIST S)	49
Average (AVG)	49
BINARY (BIN)	49
Format (Format)	49
Frames Per Scan (FPS)	50
Period (Period)	50
QPKTS (QPKTS)	50
Temperature Range Over Range Values (RANGET)	50
Voltage Range Over Range Values (RANGEV)	51
Scan Rate (RATE)	51
Units (UNITS)	52
Scan Trigger (XSCANTRIG)	52
Channel Correction Variables (LIST P)	53
PT (PT)	53
PT <type> (PT <type>)	54
Identification Variables (LIST I)	55
Auto Connect (AUTOCON)	55
Echo (ECHO)	55
Host (HOST)	55
Host Command (HOSTCMD)	55
Port (PORT)	56
RTD Maximum Slew Limit (RTDMAXSLEW)	56
Thermocouple Maximum Slew Limit (TCMAXSLEW)	56
Title 1 (TITLE1)	56
Title 2 (TITLE2)	56
Bootloader Variables (LIST IP)	57
DTS4050 IP Address (IPADD)	57
DTS4050 Subnet Mast (SUBNET)	57
DTS4050 MAC Address (MAC)	57

Login (LOGIN)	57
Password (PASSWORD)	58
Login 1 (LOGIN1)	58
Password 1 (PASSWORD1)	58
Allow Anonamous Logon (ALLOWANON)	58
Application File (APP)	58
Gateway (GW)	59
Calibration Variables (LIST C)	59
A/D Calibration Averaging (CALAVG)	59
Number of Calibration Setpoints (NUMPTS)	59
Number of Calibration Coefficients (NUMCOEF)	59
Number of Calibration Temperatures (NUMTEMPS)	60
Precision Time Protocol Variables (LIST PTP)	61
PTP Enable (PTPEN)	61
Tune (TUNE)	61
Syslog Severity Level (SLL)	61
Statistical Data Destination (STAT)	62
Start Scan Time (SST)	62
Start Scan Date (SSD)	62
Update Clock (UC)	63
Interval (INTERVAL)	63
Clock Drift Adjustment (ADJDRIFT)	63
UTC Offset (UTCOFFSET)	63
Network Identification Variables (LIST ID)	64
Model (MODEL)	64
Serial Number (SERNUM)	64
Version (VER)	64
IP Address (IPADD)	64
Channel Identification Variables (LIST DEF)	65
Channel Definitions (DEF)	65
Limit Variables (LIST LI)	65
Limit (LIMIT)	65
Channel Labels (LIST LA)	65
Channel Label (LABEL)	65
Thermocouple Variables (LIST T)	66
Thermocouple Type (TYPE)	66
RTD Correction Variables (LIST RPC)	67
RTD Correction (RPC)	67
RTD Conversion Volts to Ohms (LIST RTD)	68
RTD 1 (RTD 1)	68
RTD 2 (RTD 2)	68
RTD 3 (RTD 3)	68
RTD 4 (RTD 4)	68
RTD 5 (RTD 5)	69
RTD 6 (RTD 6)	69
RTD 7 (RTD 7)	69
RTD 8 (RTD 8)	69
Channel Gain Correction Variables (LIST G)	70
Gains (GAIN)	70
Channel Offset Correction Variables (LIST O)	70
Offsets (OFFSET)	70
RTD Calibration Variables (LIST U)	71

ARPC (ARCPC)	71
ARPCON (ARPCON)	71
Maximum RTD Delta (MAXDELTA)	71
Number of RTD Setpoints (RNUMPTS)	71
Number of RTD Coefficients (RNUMCOEF)	72
DTS Packet Definitions	73
Packet Type Table	73
Host Control Packets	73
Command Packet	73
DTS to HOST	74
Binary Data Packets (DTS4050/16 Channel Module)	74
Binary Data Packets (DTS4050/32 Channel Module)	75
Binary Data Packets (DTS4050/64 Channel Module)	76
General Status Byte	77
General Status Byte	77
Channel Status Byte	78
Channel Status Byte	78
RTD Units	78
ASCII Data Packet	79
Unformatted Without PTP Data	80
Unformatted With PTP Data	80
Formatted	81
Network Protocols Supported	81
SECTION 6: MAINTENANCE	83
Calibration	83
A/D Calibration (ADCAL)	83
Internet Explorer Setup for FTP	83
DTS4050 Firmware Installation (Windows XP & 7)	84
Operating in Bootloader Mode	85
APPENDIX	87
Appendix A: Thermocouple Information	87
Thermocouple Basics	87
Sources of Error in Thermocouple Measurements	88
Noise in Thermocouple Circuits	88
Thermocouple Design	88
Thermocouple Types and Descriptions	89
International Thermocouple and Extension Wire Color Codes	90
Appendix B - Software Change List	91

[This page intentionally left blank]

SECTION 1: SPECIFICATIONS

GENERAL SPECIFICATIONS

Size (WxHxD)*	
16Tx	6.19" x 5.12" x 13.5" (15.72cm x 13.00cm x 34.29cm)
32Tx	10.75" x 5.58" x 12.0" (27.31cm x 14.17cm x 30.48cm)
64Tx	10.75" x 5.58" x 23.32" (27.31cm x 14.17cm x 59.23cm)
Weight	
16Tx:	13.0 lbs (5.91 kg)
16Tx panel jack:	12.0 lbs (5.45 kg)
32Tx:	15.5 lbs (6.80 kg)
32Tx panel jack:	15.0 lbs (6.13 kg)
64Tx:	25.0 lbs (11.36 kg)
Thermocouple Types	
Screw Terminal:	B, E J, K, N, R, S and T
Panel Jack:	E, J, K, S and T
Accuracy**	
E, J, K, N and T	±0.5°C
R and S	±2.0°C
B	±4.0°C
UTR Accuracy	
	±0.1°C
A/D Resolution	
	22 Bit (each channel)
Data Output	
	°C, °F, °R, K, mVolts, Counts
Data Output Rate	
16Tx	40 samples/channel/second
32Tx	20 samples/channel/second
64Tx	10 samples/channel/second
Communications	
Ethernet	100Base-T, TCP/IP or UDP
Serial	RS-232 (limited configuration only)

Power Input	18-36Vdc
Power Requirements	
Standard—No heater:	
16Tx:	.58 Amps @ 28Vdc
32Tx:	.83 Amps @ 28Vdc
64Tx:	1.45 Amps @ 28Vdc
With Optional Heater:	
16Tx:	1.6 Amps @ 28Vdc
32Tx:	4.8 Amps @ 28Vdc
Common Mode Rejection	
	160 db @ 0-60Vdc
Channel to Channel Isolation	
	1000Vdc
Input/Output Isolation	
	600Vdc

ENVIRONMENT SPECIFICATIONS

Operating Temperature	
Without Heater	-5 to 60 °C
With Heater	-20°C to 60°C (16 & 32Tx only)
Humidity	
Operation	5 to 95% RH, Non-Condensing
Storage	5 to 95% RH, Non-Condensing

* All dimensions for screw-terminal variants
 ** System accuracy specifications are valid after a minimum of two hour warm up period. Accuracy does not include thermocouples, thermocouple extension wires or panel jack connector option.

DTS4050/16Tx - SCREW TERMINAL OUTLINE DRAWING

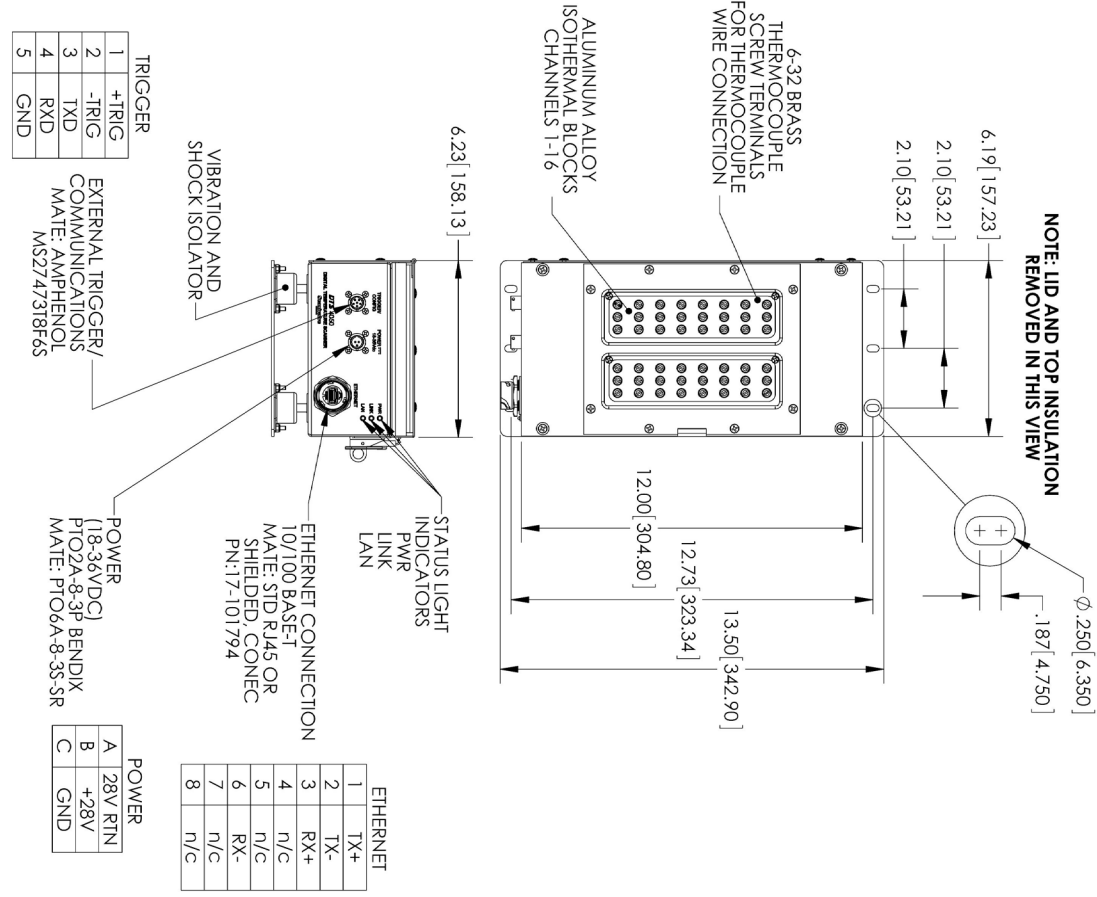
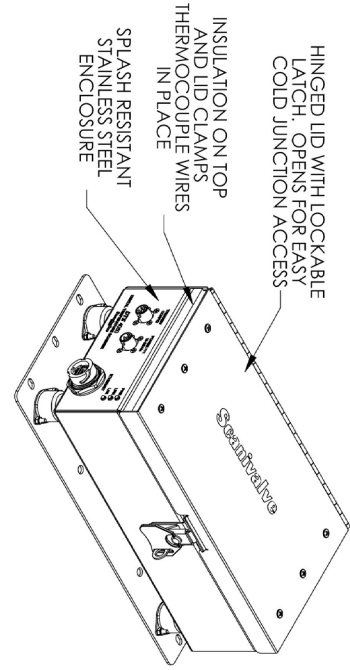
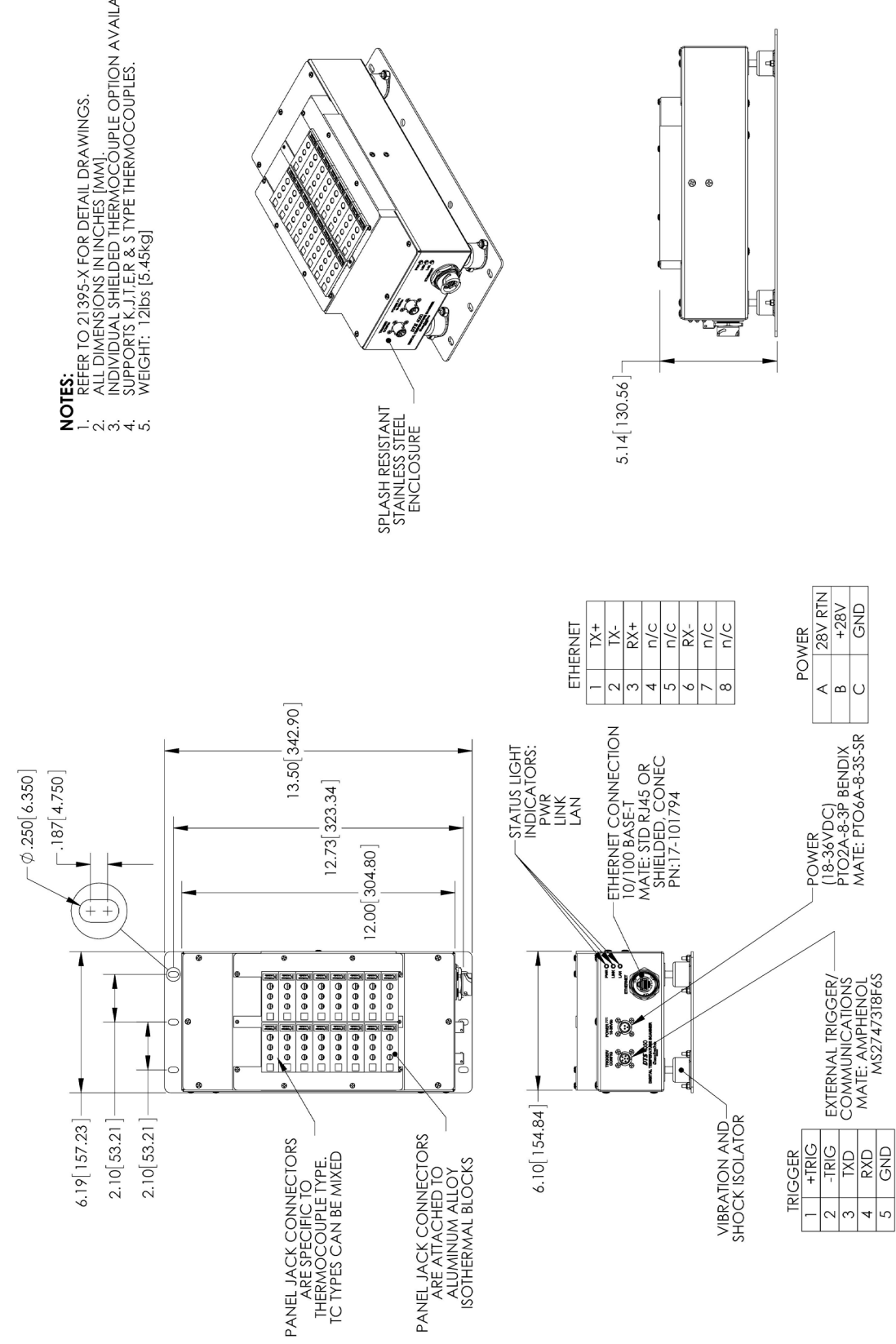

FIGURE 1.1 - PHYSICAL SPECIFICATION, DTS4050/16TX, SCREW TERMINAL INPUTS



- NOTES:**
1. REFER TO 21395-X FOR DETAIL DRAWINGS.
 2. ALL DIMENSIONS IN INCHES [MM].
 3. INDIVIDUAL SHIELDED THERMOCOUPLE OPTION AVAILABLE.
 4. SUPPORTS K,J,T,E,R & S TYPE THERMOCOUPLES.
 5. ALLOW A MINIMUM OF 7.00 IN [17.78 CM] VERTICAL CLEARANCE TO OPEN THE LID WHEN MOUNTING THIS UNIT.
 6. WEIGHT: 13lbs [5.9kg]

DTS4050/16Tx - PANEL JACK OUTLINE DRAWING



- NOTES:**
1. REFER TO 21395-X FOR DETAIL DRAWINGS.
 2. ALL DIMENSIONS IN INCHES [MM].
 3. INDIVIDUAL SHIELDED THERMOCOUPLE OPTION AVAILA
 4. SUPPORTS K,J,T,E,R & S TYPE THERMOCOUPLES.
 5. WEIGHT: 12lbs [5.45kg]

FIGURE 1.2 - PHYSICAL SPECIFICATION, DTS4050/16TX, PANEL JACK INPUTS

DTS4050/32Tx - SCREW TERMINAL OUTLINE DRAWING

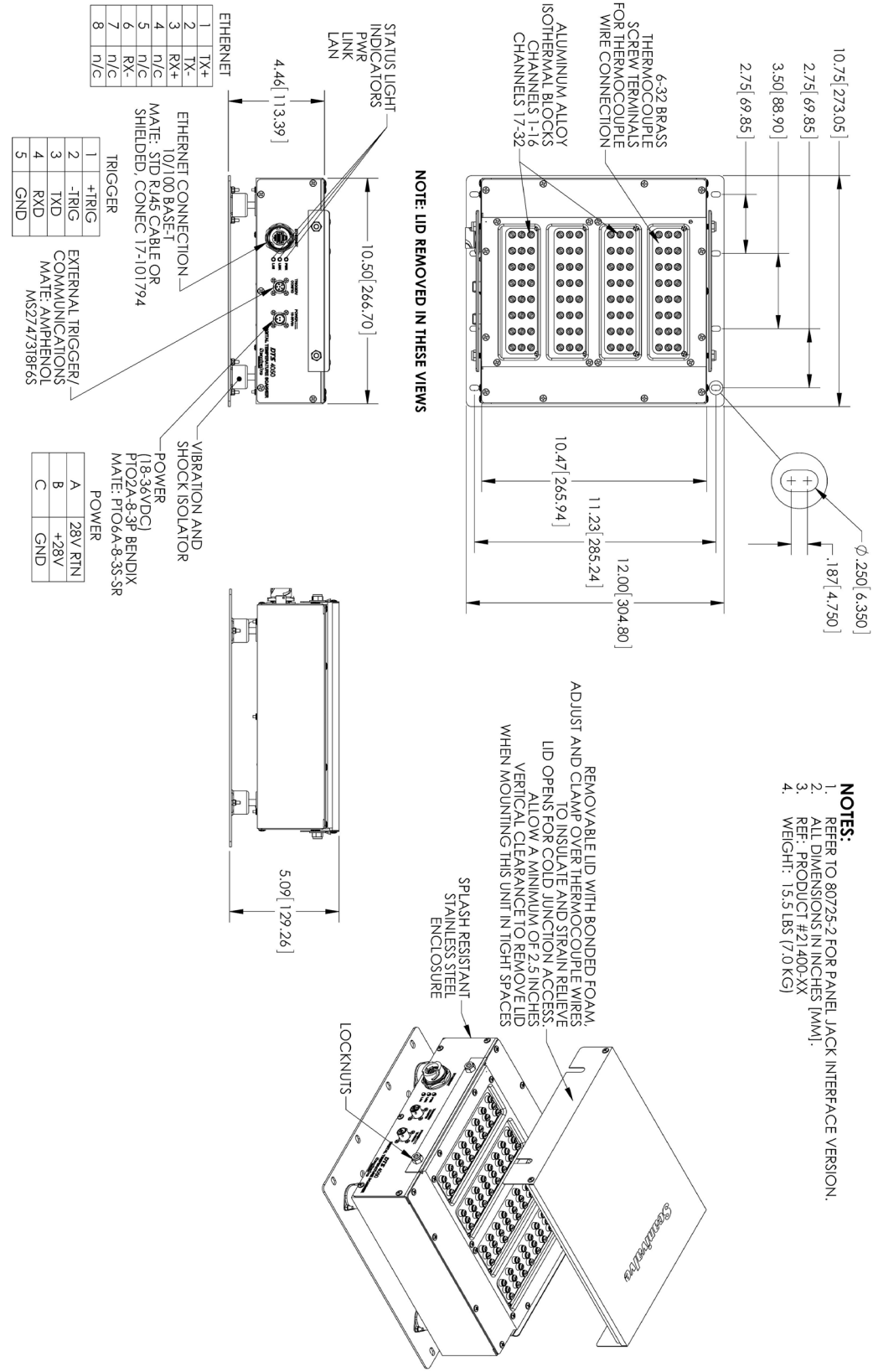

FIGURE 1.3 - PHYSICAL SPECIFICATION, DTS4050/32TX, SCREW TERMINAL INPUTS

DTS4050/32Tx - PANEL JACK OUTLINE DRAWING

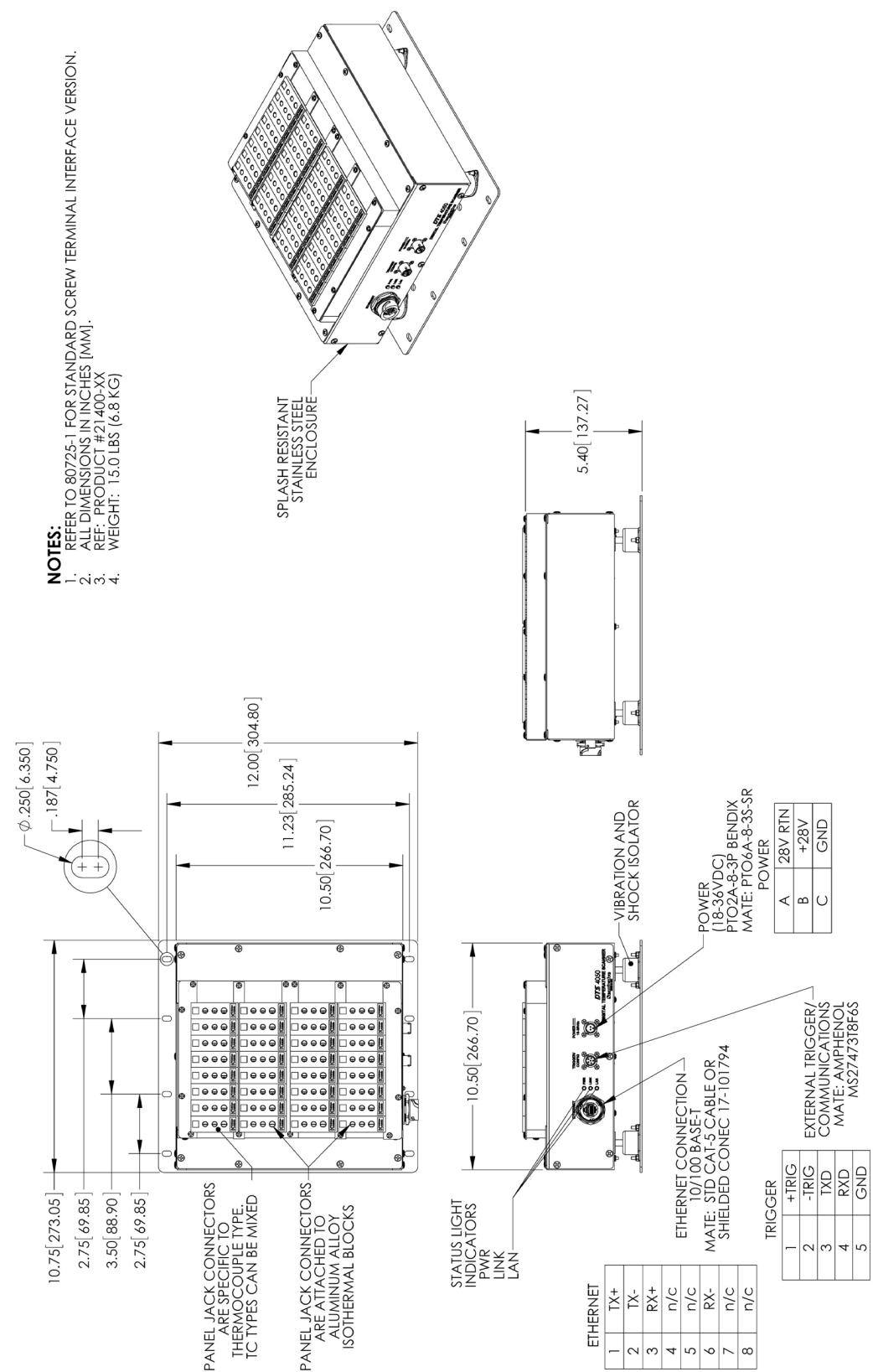

FIGURE 1.4 - PHYSICAL SPECIFICATION, DTS4050/32TX, PANEL JACK INPUTS

DTS4050/64Tx OUTLINE DRAWING

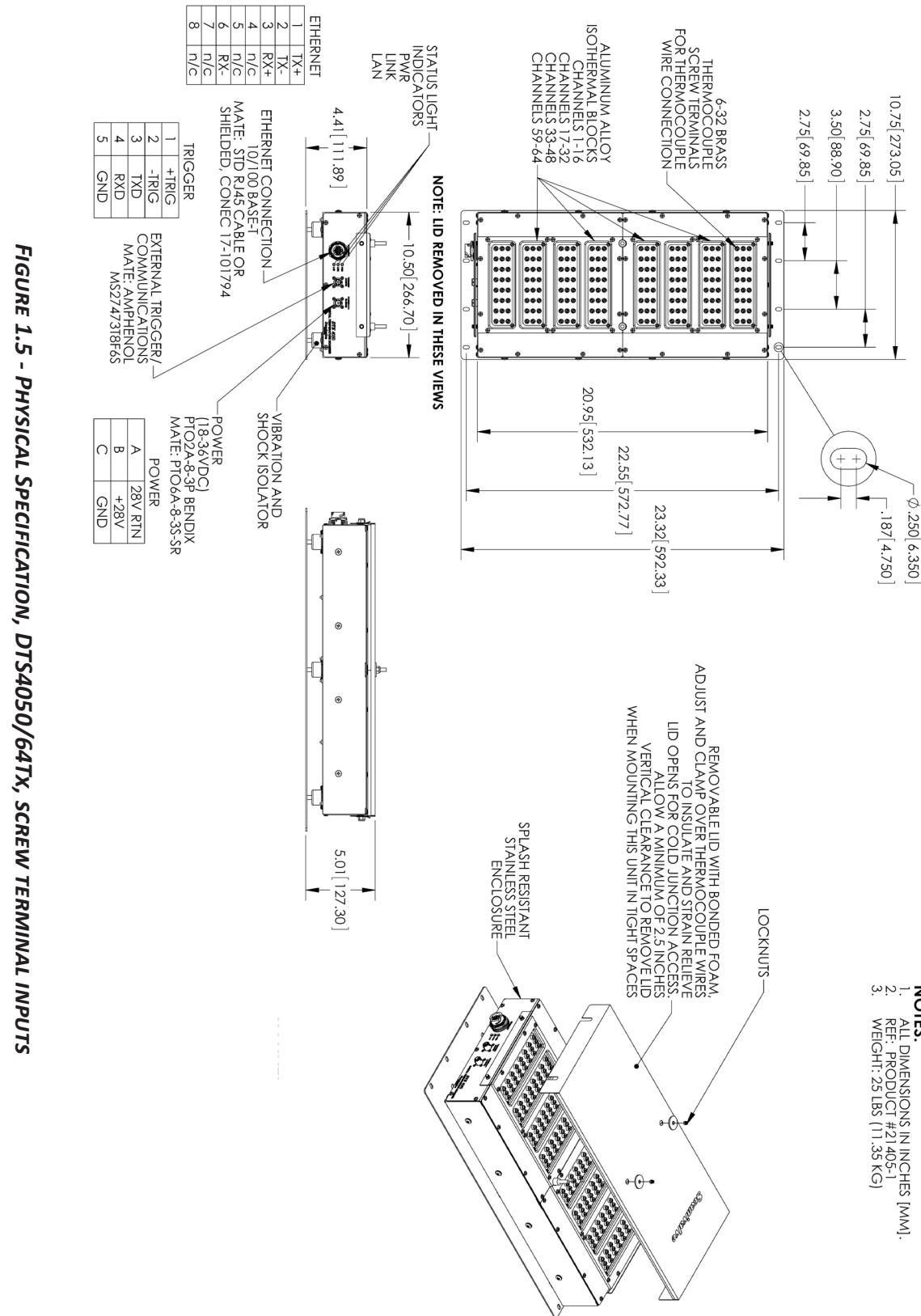

FIGURE 1.5 - PHYSICAL SPECIFICATION, DTS4050/64Tx, SCREW TERMINAL INPUTS

SECTION 2: INTRODUCTION

GENERAL DESCRIPTION

The DTS4050 series thermocouple acquisition system represents the next generation of intelligent temperature scanning. This Digital Temperature Scanner incorporates 16, 32 or 64 pair of thermocouple inputs, a 22 bit A/D converter for each input channel, RAM and a DSP processor. The DTS is packaged in a rugged, shock mounted, stainless steel enclosure.

An Isothermal block is incorporated for the Uniform Temperature Reference (UTR), with a ± 0.1°C accuracy. The temperature of each UTR block is measured using two PT100 RTDs. A single UTR block can act as the reference for 16 thermocouple inputs. NIST thermocouple tables for standard thermocouple types are stored in Flash Memory. The DSP processor uses these look-up tables to convert mV inputs to Engineering units. Temperature data may be output in °C, °F, °R, K, mVolts, Counts. The DTS4050 total system error does not include extension wire and external connectors, or panel jacks.

Multiple standard thermocouple types may be used with this intelligent thermocouple scanner. The DTS4050 can accept grounded and un-grounded thermocouples.

MODULE CONFIGURATIONS

The DTS4050 is available in 16, 32 or 64 input versions. Several optional configurations are available in order to meet the requirements of specific tests.

SCREW TERMINAL

This is the standard configuration for all DTS4050 modules. Thermocouples are terminated at the DTS4050 with #6x32 brass screws into the UTR block. DTS4050 modules are available in versions that will accept 16, 32 or 64 shielded thermocouples. The top cover and insulation isolate the UTR from small temperature changes giving this unit the best accuracy.

PANEL JACK VERSION

DTS4050 modules may have panel jacks installed as an option in 16Tx and 32Tx version. This option uses either Omega TPJ series or UPJ series panel jack receptacles and is available for type E, J, K, S and T thermocouples only. This option reduces the overall accuracy of the module by a factor of two. This error may be calibrated out by the user using the Gain and Offset terms. Unused panel jacks must be plugged to prevent "cold spots" on the UTR which will cause errors.

PANEL MOUNT VERSION

DTS 4050/64Tx modules may be ordered in either the standard shock mount configuration or in an optional Panel mount configuration. The Panel Mount configuration is designed to be mounted in a standard 19 inch rack mount cabinet. The mounting ears may be reversed to facilitate the most convenient mounting configuration

HEATER OPTION

16 and 32 channel DTS4050 modules can be equipped with an internal heater for cold environment applications. The heater kit option increases the DTS4050's operational ambient temperature range to -20°C to 60°C by maintaining the internal temperature of the module at approximately +20°C. With a heater installed, the power requirements for the DTS4050 module increase to:

DTS4050/16Tx:	1.6A @ 28Vdc
DTS4050/32Tx:	4.8A @ 28Vdc

The standard nominal power range of 18-36Vdc still applies. The power consumption of the module will decrease once the temperature of the module has stabilized.

ENVIRONMENTAL CONSIDERATIONS

DTS4050 modules are constructed with a rugged, corrosion resistant stainless steel case. This case is designed with withstand normal test cell, flight test, educational, light industrial or similar environments. The case is splash resistant but not water proof. If any moisture gets spilled or splashed on the DTS module, wipe it dry immediately to prevent damage to the module. The DTS module should not be mounted outdoors.

The DTS module is designed for rugged applications and incorporates shock mounts for vibration isolation and Bendix/Amphenol connectors for power and serial inputs as well as a Conec connector with optional protective shell for the Ethernet connection.

The DTS module should not be mounted in a location where it may be subjected to extreme temperature shifts or ambient temperatures outside of the specified operating range of the module. Pay careful attention to prevent any temperature "gradients" across the module as the UTR blocks must be at a completely consistent temperature. Keep in mind that the internal temperature of the module will run several degrees warmer than ambient temperature.

[This page intentionally left blank]

SECTION 3: OPERATION

UNPACK & INVENTORY

When you first unpack the DTS module, begin by inspecting and inventorying the contents of the package. If any visible damage is immediately noticed or if any contents are missing, contact Scanivalve before proceeding. Standard modules are shipped with the following contents as a minimum:

1. DTS4050 module
2. Certificate of calibration
3. Full calibration report CD
4. DTS resource CD
5. Trigger/configuration cable connector
6. Power cable connector
7. Ethernet cable connector

MOUNTING

The DTS module comes with a mounting plate attached to the bottom using vibration dampers. This mounting plate accepts mounting hardware up to 1/4" (6.4mm) in diameter. The DTS module can be mounted in most orientations. Because the DTS Uniform Temperature Reference block (UTR) has two RTDs to measure the temperature, the DTS should NOT be mounted in an orientation that puts these RTDs vertical to each other. Mounting the DTS such that the RTDs are vertical to each other produces a temperature gradient across the UTR block that cannot be accurately represented by the two RTD readings. This is only a concern if the DTS is mounted "vertically," such as on a wall. If the DTS does need to be mounted vertically, then 16 channel units must be mounted with the connectors horizontal (left or right). 32 and 64 channel units must be mounted with the connectors vertical, on the top or bottom face. Additionally, ensure that the DTS module is mounted in an environment that conforms to the requirements described in "Environmental Considerations" on page 13.

A minimum clearance of 6.25" must be left above 16Tx module and 1.5" above 32Tx & 64Tx module in order to open or remove the insulating cover.



CAUTION! Mounting the DTS module inadequately or in an environment that does not conform to the recommendations can result in permanent damage to the module.

WARM-UP

After applying power to the DTS module, a minimum of two hours is required to allow the module temperature to become stable before collecting data. It is recommended

that if time allows, the warm-up period should be extended to three hours for most applications.

COMMUNICATIONS

The DTS module is designed primarily for Ethernet communications. This provides a means to configure the DTS module as well as scan and collect data from the module. A serial RS-232 port is also provided. The serial connection is designed to provide emergency communications should Ethernet communications not be available. Several important module variables can be configured through the serial port, but possibly the most important is the Ethernet IP address. If the IP address of the unit has been lost, a Serial connection is the only way to reset the IP address. See "Operating in Bootloader Mode" on page 85 for step by step instructions on entering the bootloader and change the module's IP address.

SERIAL COMMUNICATIONS

Every DTS4050 module has an RS-232 serial output. It is available through the 'Serial Communications/Trigger' connector on the front face of the module. The bulkhead connector for the 'Serial Communications/Trigger' connection on the module is an Amphenol JTPO2RE8-6P. All DTS modules are shipped with a mating connector (Amphenol JTO1RE8-6SR) that can be used to fabricate a Serial Communications/Trigger cable. Alternately, a Serial Communication/Trigger cable can be ordered from Scanivalve using the Scanivalve part number 155829.

The wiring diagram for the RS-232 output is shown below. The cable wiring must connect the Tx output from the host computer to the Rx input of the DTS module. Also, the RX input of the host computer must connect to the Tx output of the DTS module.

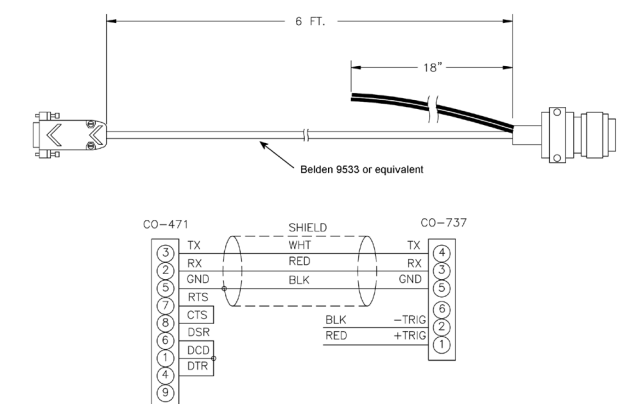

FIGURE 3.1 - SERIAL COMMUNICATION/TRIGGER CABLE

Settings for establishing a serial connection to the DTS module are as follows:

- Bits per second: 9600 BAUD
- Data bits: 8
- Parity: none
- Stop bits: 1
- Flow control: none

The Serial Communications port also serves as the input for the external scan trigger. For more information on externally triggering scans, "Scanning With An External Trigger" on page 18.

For information on changing the boot parameters including the module's Ethernet IP address, see "Operating in Bootloader Mode" on page 85.

ETHERNET COMMUNICATIONS

A DTS4050 has one Ethernet connection, 10/100Base-T with MDIX auto-crossing. This is the primary means of communications with the DTS. All DTS modules use a Conec RJ45-IP67 series connector for the Ethernet connection. This connector offers the ability to use a standard RJ-45 Ethernet cable or, when needed the shield can be installed for a more rugged connection. Shielded Category 5E cable or better is recommended for all Ethernet connections.

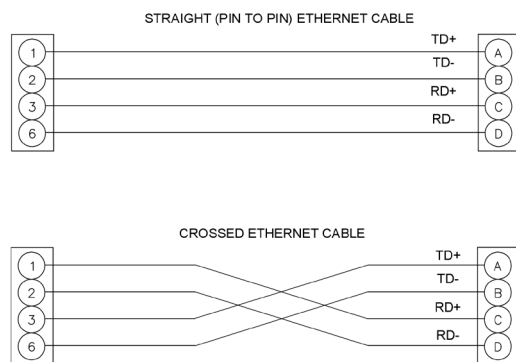

FIGURE 3.2 - 10BASE-T ETHERNET CABLES

Before an Ethernet connection can be established the IP address need to be configured. In order to be compatible, the IP address of the module and host computer must share the first two octets. The third and fourth octets of the IP address is variable, although it is recommended that the third octet also be shared between the host computer and the module.

Example of matching the first three octets (recommended):

- Host computer: 191.30.80.100
- DTS module: 191.30.80.125

Example of matching the first two octets:

- Host computer: 191.30.1.100
- DTS module: 191.30.80.125

The IP address of a Windows XP host computer can be changed under:

- Control Panel -> Network Connections -> Local Area Network -> Properties -> Internet Protocol (TCP/IP) -> Properties.

The IP address of a Windows 7 host computer can be changed under:

- Control Panel -> Network and Sharing Center -> Local Area Connection -> Properties -> Internet Protocol Version 4 (TCP/IPv4) -> Properties.

DTS modules are shipped with a preset IP address that uses the following format:

- DTS4050/16Tx: 191.30.100.xxx
- DTS4050/32Tx: 191.30.105.XXX
- DTS4050/64Tx: 191.30.110.XXX

Where "XXX" is the last three digits of the unit's serial number.

For information on changing the DTS module's IP address, see "Operating in Bootloader Mode" on page 85.

CLIENT/HOST OPTIONS

Once the module has been connected and the IP address has been configured, communications can be established with the DTS module. Communications can be made through several software packages including:

- PC - TCP/IP
- PC - UDP
- PC - ScanTel (Scanivalve PN: 155406-01)
- PC - LabVIEW Configuration Utility (Scanivalve PN: 155384-01)
- PC - LabVIEW Development Kit (Scanivalve PN: 155385-01)
- PC - OPC Server (Kepware PN: EX5-SCNVE-NA00)
- PC - Windows HyperTerminal

PC - TCP/IP

The user may write their own TCP/IP interface using the software specification portion of this manual. This interface should allow the user to:

- Issue commands to any or all DTS modules on the network.
- Display returned information or scan data from the DTS module(s).
- Write returned information or scan data to the client/host in TCP/IP format.
- Determine the addresses of DTS module(s) on the network.

PC - UDP

The user may write their own UDP interface using the software specification portion of this manual. This interface should allow the user to:

- Issue commands to any or all DTS modules on the network.
- Display returned information or scan data from the DTS module(s).
- Write returned information or scan data to the client/host in UPD format (no handshaking).
- Determine the addresses of DTS module(s) on the network.

PC - SCANTEL

ScanTel a free communications utility designed by Scanivalve to communicate with Scanivalve products including DTS modules. It is a text based, command line program that allows users to connect to a single DTS module and modify the configuration variables, upload or download coefficients and collect data in both TCP/IP and UDP format.

PC - LABVIEW CONFIGURATION UTILITY

The Scanivalve LabVIEW Configuration Utility is software package that offers a very intuitive and simple way to connect to and modify all of the DTS module's configuration variables. It also allows the user the ability to upload a configuration file and scan and collect data. The scanning and data collection is limited to 5Hz due to the graphic nature of the program. The LabVIEW Configuration Utility is based on a LabVIEW 2009 runtime which is included with the installation disk.

PC - LABVIEW DEVELOPMENT KIT

The Scanivalve LabVIEW Development Kit is for users desiring to customize a LabVIEW driver for DTS modules. The Development Kit is compatible with LabVIEW 8.2, 8.6 and 2009. The LabVIEW Configuration Utility is included with the Development Kit.

PC - OPC SERVER

Kepware has written an OPC Server driver to interface a PC running in an OPC environment with a 16 channel DTS module. The OPC server can be ordered directly from Kepware using the part number: EX5-SCNVE-NA00. This program is designed to operate in Windows 2000 or Windows XP.

PC - HYPERTERMINAL

HyperTerminal is a Windows program included as part of Windows 2000, XP and Vista Operating Systems. This program permits a user to connect to a single DTS module, modify the configuration variables, upload or download coefficients and collect data. HyperTerminal provides a means for both Serial RS-232 and Ethernet connections. It is a text based command line program.

SCANNING

Once the DTS module has been installed, powered up and allowed to thermally stabilize data can be collected. There are several configuration variables that effect how the DTS module scans and how the data is output. The scan rate is controlled by two variables: 'period' and 'average'. Alternately, these two variables can be set automatically using the 'rate' variable. The length of the scan sample is determined by the 'frames per scan' (FPS) variable and the data output format is determined by the 'format' variable. The DTS can be configured for 'free run' mode where after the 'SCAN' command is send the DTS module will scan continuously until the frames per scan (FPS) term is met, or it can be triggered to scan and output data upon receipt of a scan trigger (either external or a software trigger). The following is a brief list of common commands that effect how the DTS collects data.

AVG	RATE
BIN	PERIOD
CVTUNIT	TIME
EU	UNITS
FORMAT	XSCANTRIG
FPS	TYPE

More information on all of these configuration variables can be found in "Section 5: Software" on page 25.

To initiate scanning, simply send the command: 'SCAN'. If a scan trigger is not being used, data will begin to be output from the DTS module over the Ethernet connection. This data can be collected and recorded using one of the options described in "Client/Host Options" on page 16. If a scan trigger is being used, after the 'SCAN' command is sent one frame of data will be output each time a scan trigger is received.

SCANNING WITH AN EXTERNAL TRIGGER

The DTS module can be triggered to scan with either a hardware or a software trigger. The DTS also incorporates a “trigger divider.” This function allows the unit to be paced at a rate slower than the input trigger rate. More information on the trigger input divider can be found in “Scan Trigger (XSCANTRIG)” on page 52.

HARDWARE TRIGGER

The external trigger input is optically isolated to prevent grounding problems. It is a TTL level, edge sensing device. It requires a minimum signal of 4.5 Vdc @ 6.5 mA. It may accept voltages as high as 15 Vdc. The external trigger will only be active if the XSCANTRIG variable is set to 1 or greater. When a ‘SCAN’ command is issued through the Ethernet connection, the module enters the scan mode and waits for a trigger. The module will return an averaged frame of data for each trigger pulse received. This will continue until the Frames Per Scan (FPS) term is met or until a ‘STOP’ command is issued. Trigger pulses are received through pins 1 (+Trig) and 2 (-Trig) of the ‘Serial Communications/Trigger’ connector on the front of the DTS module. More information on the ‘Serial Communications/Trigger’ connection can be found in “Serial Communications” on page 15.

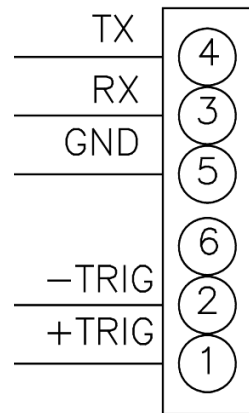
**FIGURE 3.5 - TRIGGER WIRING****SOFTWARE TRIGGER**

The software trigger will only be active if the software variable XSCANTRIG is set to 1 or greater. When a SCAN command is issued through the Ethernet connection, the module will enter the SCAN mode and wait for a trigger. An averaged frame of data will be output as soon as the TRIG command or a <TAB> character (9 HEX or Control I) is received. Data will be output with each successive trigger command. This will continue until the Frames Per Scan (FPS) variable value is met, or until a STOP command is issued.

DIP SWITCH SETTINGS

The processor board has 4 DIP switches that affect the operation of the software. These switches are only read at power up. Changes to the dip switches are not effective until the power is cycled.

- SW1 - When this switch is off, the application automatically boots on power up. When this switch is on, the DTS4050 remains in the bootloader mode. Default is on.
- SW2 - When this switch is off, the boot loader will run in the debug mode. Debug output is directed to the serial port. Default is on.
- SW3 - This switch sets the device type for the boot loader. Off is for a DTS, on is for a DSA.
- SW4 - Spare.

“Figure 3.6 - DIP Switches” shows the DTS4050 end cover removed and the location of the DIP switches on the processor board. For all DIP switches, “on” is away from the board, towards the bottom of the DTS.

**FIGURE 3.6 - DIP SWITCHES****DSP BOOT LOADER**

The Scanivalve DSP Boot Loader permits a user to upload the DTS4050 application via FTP. The boot loader runs the FTP server. It has been tested on Mozilla ‘FileZilla’ and Windows Explorer drag and drop. Any additional file transfer protocols or additional FTP client support modification will be made solely to the application. For more information on boot loader operation, refer to “Operating in Bootloader Mode” on page 85.

FTP

The FTP server supports the following FTP commands prior to login:

- USER - Allows the user to enter the user’s name. Anonymous is allowed.
- PASS - Allows the user to enter the password.
- QUIT - Disconnects from the FTP server.

The FTP server supports the following FTP commands after

login:

- RETR - Initiates a file transfer from the DTS to the host.
- STOR - Initiates a file transfer from the host to the DTS.
- PASV - Sets up data port so client can connect to server’s port.
- LIST - Returns a directory listing of the files stored on the DTS.
- SIZE - Returns the size in bytes of the file.
- DELE - Deletes the file.
- NOOP - No operation. Mostly used by the client as an “are you still there” command.

ASCII format transfers are the only supported transfer type. Passive data connections are the only supported connection type. This allows data to be transferred without the server initiating a connection to the client. This could cause firewall problems.

BOOT LOADER AND APPLICATION FILE SYSTEM

File names are limited to the 8.3 format with no spaces allowed. Only one drive is supported. Because the DTS4050 does not have a time and date clock, all files created will have a date of Aug 8, 2008. No subdirectories are supported, however, if a file path is included in the file specification only the file name portion is used. The file will be written in the root directory of the drive. The disk drive will hold a maximum of 1024 files, or 2GB of data.

HOST COMMUNICATION

Commands are issued to the DTS4050 and response is returned via either the Ethernet port or the Config port. The boot loader returns the command information to the host that it received its command. That is, when the command is received from the network it is returned to the network. When it is received from the serial port, it is returned to the serial port. The SCAN function is not supported in Config/Serial operation. The network supports TCP/IP connection using Telnet or HyperTerminal.

COMMANDS

When a command is complete, the prompt character, the greater than character “>”, is output preceded by a carriage return and line feed.

The commands listed below are supported by the boot loader and the executable program, unless otherwise noted. They may be viewed and modified in the DTS4050 executable program.

- VER - Returns the version of the Boot Loader. NOTE: This command is specific to the boot loader only. It should not be confused with the VER command in the application.
- FDISK - Formats the Flash to all 0’s. NOTE: This

- command is available in the boot loader only.
- LIST IP - Returns the settings of the IP group. This command is explained in detail in the software manual.
- SET <parameter> - Set the indicated parameter.
- IPADD <IP address> - Sets the IP address of the DTS. If the IPADD is changed, the power must be cycled to take effect.
- SUBNET <mask> - Sets the subnet address of the DTS. If the SUBNET is changed, the power must be cycled to take effect.
- MAC <MAC address> - Sets the MAC address for the DTS. If the MAC is changed, the power must be cycled to take effect.
- LOGIN <user name> - Sets the user name for FTP login.
- PASSWORD <password> - Sets the password associated for LOGIN.
- LOGIN1 <user name> - Sets the user name 1 for FTP login.
- PASSWORD1 <password> - Sets the password associated for LOGIN name1.
- LOGINNAS <name> - Sets the name for login to the NAS. The boot loader does not access the NAS (Network Attached Storage) device. This is a place holder in this group for compatibility with the IP group in the application.
- PASSWORDNAS <password> - Sets the password associated with LOGINNAS name.
- IPADDNAS <IP address> - Set the IP address of the NAS
- APP <application file name> - Sets the file name of the application to run. This is the file name that is used when automatically running the application from the boot loader. It is also the file name used when using the RUN command. If this file is not found, an error is returned.
- SAVE [<file name>] - Saves the configuration variables to the working directory. When an optional file name is entered, it saves the IP group settings to that file name.
- TYPE <file name> - Types the contents of the file name.
- LOAD <file name> - Loads the file name into the LIST IP configuration variables.
- DIR - Lists the file on the FLASH chip.
- DEL<file name> - Deletes the file name.
- DIP - Reads and shows the settings of the DIP switches. The following is returned: “DIP settings Auto Run Application 0 Debug 0 No Serial Host 0 Spare 0” where 1 indicates on, 0 indicates off. NOTE: This command is available in the boot loader only.
- RUN - Runs the application named in the SET APP setting. NOTE: This command is available in the boot loader only.

IEEE-1588 PTP

The DTS4050 has a hardware supported slave implementation of the Precision Time Protocol defined by IEEE 1588-2008, otherwise known as PTP V2. This protocol is used to synchronize the DTS4050 internal clock over the Ethernet network.

The primary function of the PTP is to accurately schedule the DTS4050 acquisition and timestamp the data it transmits. It can also be used to timestamp an external trigger, such as an IRIG-B pulse rate signal.

The DTS4050 may be configured to start an acquisition at a future date and time. When a SCAN command is received, the DTS4050 schedules an event for the first frame and calculates the times of the subsequent frames of data based on the RATE setting. By configuring them identically, a number of DTS4050 units may be configured to start acquiring data synchronously.

The DTS4050 may also be configured to start an acquisition at a date and time in the past. This will cause the DTS4050 to start acquiring data at the next calculated time interval specified by the start time and RATE setting. For example, if the DTS4050 is configured with a start time of 9:00:00 today, and a very slow rate of one reading per minute, it will take data at an even one minute absolute time. If a SCAN command is received at 10:00:30, it will start taking data at 10:01:00.

There are practical limits to consider when using a scan start time that has passed. If the DTS4050 is configured with a start time at the beginning of the Epoch (1970/1/1 at midnight) it must calculate the time of the next frame over a very long span, resulting in significant rounding errors. The interval between readings and the accuracy of the time stamp will not be affected, but the data may not be taken at the expected absolute time. The solution is to specify a more recently passed start time.

The DTS4050 timestamps the data in either ASCII or binary data formats, when PTP is enabled. In addition, the binary packet includes the elapsed time since the last update from the grandmaster. From this, the user can detect when and if the grandmaster has gone offline. The user may enter an offset to adjust the PTP to reflect local time and/or adjust for leap seconds. The DTS4050 does not automatically adjust for leap seconds, but it does have a command to extract and display the leap second field of the PTP packets sent by the grandmaster. The format of the DTS4050 data packets can be found in "DTS Packet Definitions" on page 73.

The DTS4050 can output status information about the control loop that synchronizes the internal clock with the grandmaster. A line of data is output corresponding to each update from the grandmaster. The offset from master (OFM) is a good measure of how well the DTS4050 is synchronized with the grandmaster. For a complete explanation of the PTP status output see "List Precision Time Protocol" on page 39 and "Precision Time Protocol Variables (LIST PTP)" on page 61.

SECTION 4: HARDWARE

ELECTRICAL CONNECTIONS

ETHERNET CONNECTION

A DTS4050 has one Ethernet connection, 10/100Base-T with MDIX auto-crossing. This is the primary means of communications with the DTS. All DTS modules use a Conec RJ45-IP67 series connector for the Ethernet connection. This connector offers the ability to use a standard RJ-45 Ethernet cable or, when needed the shield can be installed for a more rugged connection. The bulkhead end of the connector is a Conec P/N: 17-101754 and the mating protective shell (optional) is a Conec P/N: 17-101794. The pinout of the connector is as follows:

Pin	Description
1	TD+
2	TD-
3	RD+
4	RD-

Shielded Category 5E cable or better is recommended for all Ethernet connections. More information on the Ethernet connection can be found in "Ethernet Communications" on page 16.

TRIGGER/CONFIG CONNECTION

The external trigger/serial configuration connection on the DTS4050 serves a dual purpose. It is used primarily as an input source for a trigger signal, but can also be used to establish a serial connection with the unit in case an Ethernet connection cannot be established. The bulkhead connector used on the DTS is a Bendix JTO2RE8-6P, with the mate being a Bendix JTO1RE8-6S-SR. The pinout of the connector is as follows:

Pin	Description
1	+Trig
2	-Trig
3	TXD
4	RXD
5	Ground

More information on the external trigger can be found in "Scanning With An External Trigger" on page 18. Information on when and how to use the serial connection can be found in "Serial Communications" on page 15.

POWER CONNECTION

The Power connection on the DTS4050 is a Bendix PTO2A-8-3P, with the mate being a Bendix PTO6A-8-3S-SR. The pinout of the connector is as follows:

Pin	Description
1	28VDC Return
2	+28V
3	Ground

The DTS4050 accepts input voltages ranging from 18-36VDC. Nominal power consumption is as follows:

DTS4050/32Tx: .60A @ 28Vdc

If an optional heater is installed, it is powered directly through the power connection with the unit power. It is the user's responsibility to ensure that sufficient power is provided to the unit in order for proper function.

THERMOCOUPLE INPUTS

SCREW TERMINAL CONNECTIONS

Standard configuration for 16, 32 and 64 channel DTS4050 modules is with screw terminal terminations for the thermocouple inputs. Thermocouples are terminated at the DTS4050 with #6x32 brass screws into the UTR block. Each input provides a +, - and a ground lug. The ground lug for each input is independently isolated. The DTS4050 has an internal, software controlled shield connection switch that can be configured by the operator to support a variety of thermocouple grounding scenarios. See "Thermocouple Type (TYPE)" on page 66 for more information on the shielding configurations supported.

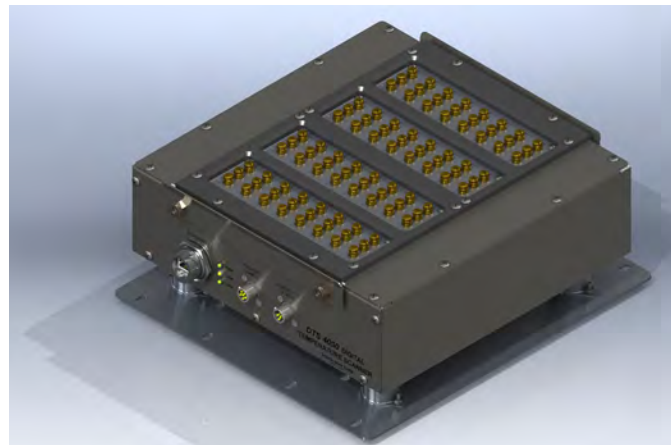

FIGURE 4.1 - SCREW TERMINAL CONNECTIONS

PANEL JACK CONNECTIONS

16 and 32 channel DTS4050 modules may have panel jacks installed as an option. Panel jacks provide a very user-friendly interface for the thermocouple inputs. The DTS4050 panel jack option uses Omega TPJ series connectors. These are compatible with standard size OTP type, 3-prong connectors. This option is available for type E, J, K, and T Thermocouples only. This option reduces the overall accuracy of the module by a factor of two. This error may be calibrated out by the user using the Gain and Offset terms. Unused panel jacks must be plugged to prevent "cold spots" on the UTR which will cause errors.

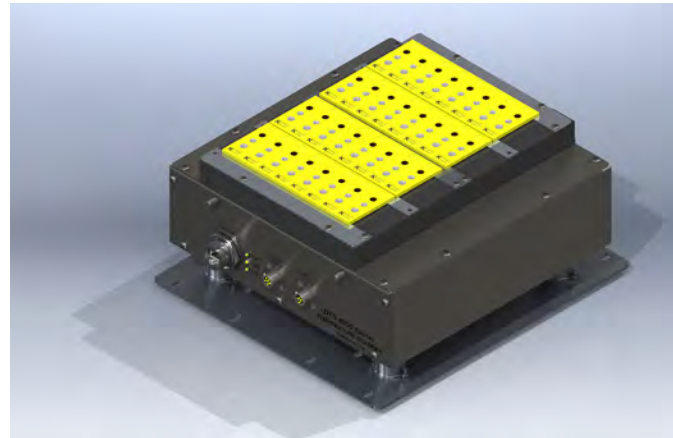

FIGURE 4.2 - PANEL JACK CONNECTIONS (32Tx SHOWN)

INSULATION COVER (SCREW TERMINAL)

Screw terminal DTS modules are provided with an insulating cover. This cover is used to insulate to UTR and maintain a stable reference temperature. It also serves as a strain relief for the thermocouples. Any time it is possible/practical, the cover should be used. DTS4050/16Tx units have an integral hinged cover while 32Tx and 64Tx unit have a removable cover. It can be easily removed by loosening the four 1/4"x20 lock nuts and lifting the cover off vertically. A minimum of 2.5" of vertical clearance above the cover is required to remove it. When reinstalling the cover, slide it in place (with the pinch bars outside of the cover), firmly press down on the cover and tighten the four lock nuts.

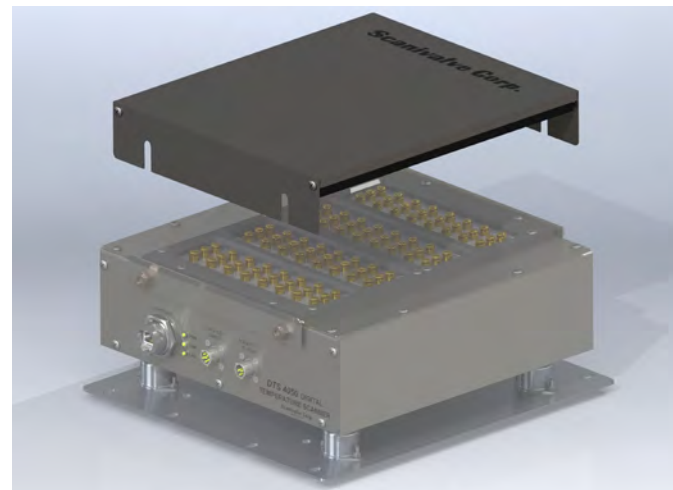

FIGURE 4.3 - INSULATING COVER (32Tx SHOWN)

THERMOCOUPLE GROUNDING SCENARIOS

DTS4050 modules provide input for shielded thermocouple wires and as such, can support multiple different thermocouple grounding scenarios. A software controlled shield connection switch is integrated into each input channel and can be individually set for each channel. The TYPE variable is used to determine whether the switch is open or closed. See "Thermocouple Type (TYPE)" on page 66 for more information about the software command. The following five grounding scenarios are supported by the DTS4050:

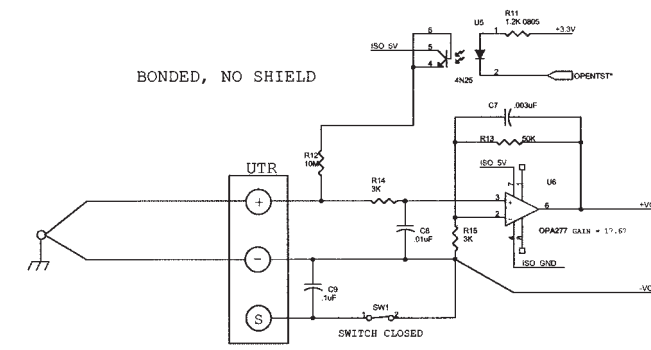

FIGURE 4.4 - BONDED THERMOCOUPLE, NO SHIELD

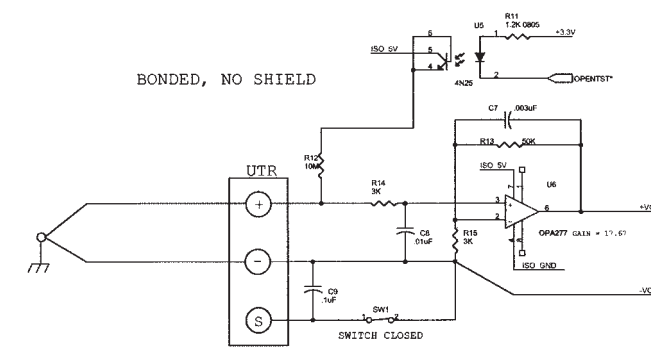

FIGURE 4.5 - UNBONDED THERMOCOUPLE, NO SHIELD

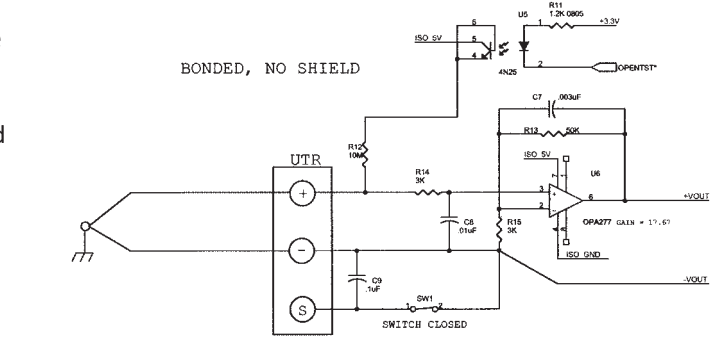

FIGURE 4.6 - SHIELDED THERMOCOUPLE, SHIELD CONNECTED AT DTS

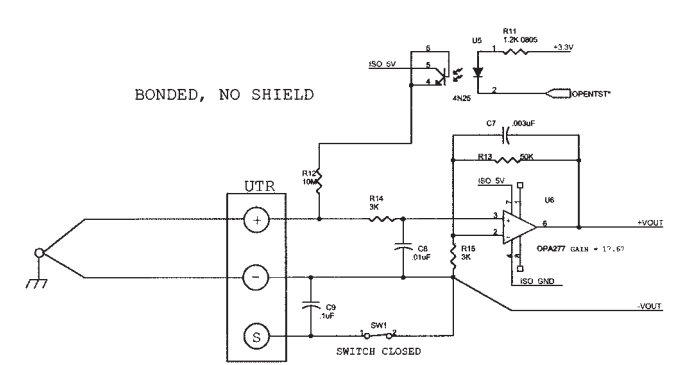

FIGURE 4.7 - SHIELDED THERMOCOUPLE, SHIELD CONNECTED AT SOURCE

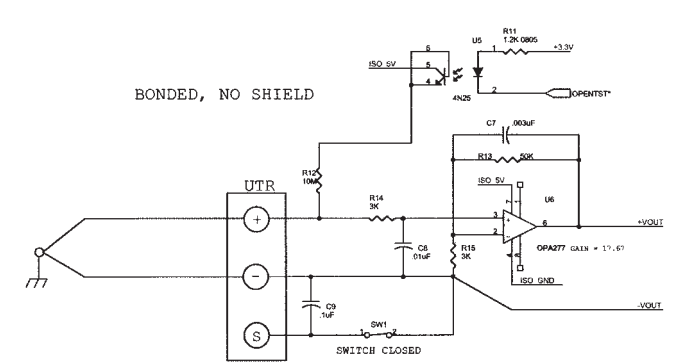

FIGURE 4.8 - UNTERMINATED PROBE THERMOCOUPLE

[This page intentionally left blank]

SECTION 5: SOFTWARE

DTS CONTROL AND CONFIGURATION

The operation of the DTS is controlled by sending commands to each unit in the form of an ASCII string terminated by a CR or LF character. The DTS receives these commands over an Ethernet or serial physical interface. The DTS Ethernet server receives commands via TCP using the Telnet port 23. The serial interface is fixed to receive and transmit at 9600 baud, full duplex, no parity and 8 data bits.

In general, commands do one of the following: 1) Configure the DTS, 2) Return information about the DTS, or 3) Return temperature data.

Commands that configure the DTS do not return any information. Some commands that take longer to execute put the DTS into a mode until the command is complete.

Commands that return information about the DTS transmit that information back to the same device that requested it over the same physical interface. The term information is used to describe what the DTS returns as the result of non-scan commands. This information is always sent as ASCII strings with each line terminated with a CR or LF.

Commands that return temperature data cause the DTS to go into a Scan Mode. The term "data" is used to describe temperature data read as the result of a scan command. Depending on the configuration, the data may be returned in ASCII formatted with VT100 control characters, ASCII unformatted, or as binary packets. Binary data transfers are delivered across an additional binary transfer port in either UDP or TCP.

TCP TELNET SERVER

The DTS supports a Telnet server on port 23. Commands are received and transmitted according to the Telnet specification. All commands must be terminated properly with one of four options. The DTS will detect and adjust to the termination option being used.

The four options are:

- CR (ASCII 13)
- LF (ASCII 10)
- LF-CR (ASCII 10 - ASCII 13)
- CR-LF (ASCII 13 - ASCII 10)

UDP ID SERVER

The purpose of the UDP ID server is to respond to broadcast packets and return information about each DTS. This is useful in determining the IP address, and other information, of each DTS on a network.

All commands supported in the Telnet server are also supported by the UDP ID server. Command line terminators are the same as required by the Telnet server.

The UDP ID server receives commands on port 7000. Information is returned on port 7001. Formatted and unformatted scan data is not output over the UDP ID server. For more information about data routing see the Data Transfer section.

SERIAL COMMANDS

Commands may be transmitted to the DTS via a serial RS-232 interface. All commands supported in the Telnet server are also supported by the serial interface. Command line terminators are the same as required by the Telnet server.

Formatted and unformatted scan data is not output over the serial interface. For more information about data routing see the Data Transfer section.

DATA TRANSFER

Scan data is routed to different devices based on the configuration of the DTS. Some configurations are not allowed and produce errors. Refer to the chart below for the various output data routing.

DTS 4050 COMMAND AND DATA OUTPUT MATRIX

Command Source	Command Output	Data Output	Bin	Host	Comment
TCP / Telnet	TCP / Telnet		X	X	Command returned to Telnet
TCP / Telnet (Scan)		TCP / Telnet	0	X	ASCII Data to Telnet
TCP / Telnet (Scan)		TCP to host <IP>	1	<IP>T	Binary TCP Data to IP Address
TCP / Telnet (Scan)		UDP to host <IP>	1	<IP>U	Binary UDP Data to IP Address
Serial	Serial		X	X	Command returned to Serial Port
Serial (Scan)	ERROR		X	X	Serial data not supported
UDP ID (Port 7000)	UDP ID (Port 7000)		X	X	ID Server command back to ID Client
UDP ID (Port 7000) (Scan)	ERROR		X	X	ID Server data not supported

COMMAND LIST**A/D CALIBRATION**

Command	A/D CALIBRATION
Command Syntax	ADCAL
Arguments	None
Description	Commands the DTS to calibrate the A/D converters. The A/D converters are calibrated automatically at power up and whenever the period configuration variable is set. It is possible for errors in the conversion if the temperature of the DTS has changed significantly since power up. In this case, the A/D converters can be calibrated by issuing this command.
Returns	<n> - end of line
Example	To calibrate the A/D converters after several hours of operation, the following command would be issued: ADCAL <CR> The A/D converters will be calibrated. The time depends upon the setting of CALAVG. If CALAVG is set to 1, the time will be several seconds. If CALAVG is set to 64 this can require several minutes.
Notes	It is recommended that a user check for A/D errors after the execution of this command. If an A/D times out or does not respond correctly, it will be disabled in software and an error will be logged. The error log is the only indication that this has occurred.

AUTO STATUS

Command	AUTOSTATUS
Command Syntax	AUTOSTATUS <enable> AS <enable> (OPTIONAL)
Arguments	Enable - 0 or 1
Description	If autostatus enable is set to 1, the DTS will automatically output the status of the DTS whenever the status changes. When set to 0, status can only be determined by issuing a STATUS command. The condition at power up and after a reboot is AUTOSTATUS disabled.
Returns	<n> - end of line
Example	To enable automatic output of the DTS status, the following command would be issued: AUTOSTATUS 1 To disable automatic output of the DTS status, the following command would be issued: AUTOSTATUS 0
Notes	AUTOTATUS was not set up as a configuration variable that could be saved to prevent conditions where the DTS would be talking on a network when it was not expected to be talking. An optional syntax is available. Either syntax will enable or disable Autostatus.

BOOTLOADER VERSION

Command	BOOTLOADER VERSION
Command Syntax	BLVER
Arguments	None
Description	Requests the version of the DTS4050 bootloader
Returns	<version string><nl>
Example	To determine the version of DTS4050 bootloader software in use, type: BLVER<CR> The DTS module will return: Bootloader Version: 1.00

CLEAR

Command	CLEAR
Command Syntax	CLEAR
Arguments	None
Description	Commands the DTS to clear any errors that have occurred. The errors are sent to the client in an ASCII Packet. ASCII Packets are described in a subsequent sections.
Returns	<nl> - end of line
Example	To clear any errors listed in the ERROR Buffer, type: CLEAR <CR> The ERROR buffer will be cleared

CLOSE HOST BINARY SERVER CONNECTION

Command	CLOSE HOST BINARY SERVER CONNECTION
Command Syntax	CLOBIN
Arguments	None
Description	Commands the DTS to close the connection to the Host Binary Server. This command will only be accepted by the DTS when the DTS is in the READY mode.
Returns	<nl> - end of line
Example	To close the connection to the Host Binary Server, type: CLOBIN <CR> The connection will be terminated

CONNECT TO HOST BINARY SERVER

Command	CONNECT TO HOST BINARY SERVER
Command Syntax	CONBIN
Arguments	None
Description	Commands the DTS to connect to the Host Binary Server configured through the HOST configuration variable. If the DTS is in the UDP mode or if a TCP connection is already established, an Error will be generated. This command will only be accepted when the DTS is in the READY mode.
Returns	<nl> - end of line
Example	EXAMPLE 1 A DTS is not connected to a server, is not in the UDP mode and is in the READY mode. A CONBIN command is generated to open a connection to the Host. Type: CONBIN <CR> The DTS will be connected to the Host. EXAMPLE 2 A DTS is not connected to a server, is in the UDP mode and is in the READY mode. A CONBIN command is generated to open a connection to the Host. Type: CONBIN <CR> The DTS will not connect to the Host and an Error will be generated. EXAMPLE 3 A DTS is not connected to a server, is in the UDP mode and is in the SCAN mode. A CONBIN command is generated to open a connection to the Host. Type: CONBIN <CR> The DTS will not connect to the Host and an Error will be generated.

CORRECT RTD VOLTAGE TABLES

Command	CORRECT RTD VOLTAGE TABLES
Command Syntax	ARPC <Reference Temperature> <RTD number>
Arguments	Reference Temperature - The indicated temperature of the standard RTD. Board - The RTD to be corrected. (1 to 8)
Description	This command calculates the voltage difference, in microvolts between the Reference RTD value and the voltage value of the RTDs in the board set entered in the command. The calculated value is stored in the ARPC variable for that board set. If ARPCON is set to 1, this value will be used to correct the board set RTD voltages before the Calander Van-Dusen correction is applied to the RTDs. The ARPC command may only be entered for the number of board sets installed. Board values outside the allowed number will result in an error.
Returns	<nl> - end of line
Example	To calculate a correction for board 1 in a 16 channel module when the reference RTD is 29.95 degrees C: Type: ARPC 29.95 1<Enter>
Notes	This command will update the ARPC variables, but the data will not be saved until a SAVE command is issued. Scanivalve Corp recommends that a user verify that the correction generated is valid before issuing a SAVE command. The values stored in the ARPC variables will be lost if power is cycled before a SAVE command is executed.

ENTER CHANNEL CALIBRATION SETPOINTS

Command	ENTER CHANNEL CALIBRATION SETPOINTS
Command Syntax	PT <index> <volts> [channel]
Arguments	Index - The setpoint number, 0 to 7 for setpoints 1 to 8. Volts - The applied voltage. Channel - Optional: If not specified the setpoint voltage will be applied to all channels.
Description	This command syntax is only used when NUMTEMPS is set to 0. This command enters the voltage correction to be applied at a given setpoint for one or more channels. The values for the setpoints do not have specific limitations.
Returns	<nl> - end of line
Example	To enter a value for setpoint 1 for all channels, type: PT 1 1.256<Enter> To enter a value for setpoint 2 for channel 9, type: PT 2 1.744 9<Enter>
Notes	This command syntax is used only if NUMTEMPS is set to 0. The value of NUMTEMPS MUST NOT be modified by an end user without detailed and specific training from Scanivalve Corp. If the value of NUMTEMPS is modified after the unit has been calibrated, ALL current calibration coefficients will be LOST.

ENTER RTD CALIBRATION SETPOINTS

Command	ENTER RTD CALIBRATION SETPOINTS
Command Syntax	RPC <index> <volts> <board>
Arguments	Index - The setpoint number, 0 to 7 for setpoints 1 to 8. Volts - The applied voltage. Board - The A/D board, 1, 2, 3 or 4
Description	This command enters the voltage correction to be applied at a given setpoint for the RTD=s. The values for the setpoints must be between 0.095 Vdc and 0.131 Vdc which represents temperatures from -13 ° C to 80 ° C . The voltage for board 1 must be inserted in the RTD1 input. The voltage for board 2 must be inserted in the RTD3 input. The voltage for board 3 must be inserted in the RTD5 input. The voltage for board 4 must be inserted in the RTD7 input.
Returns	<nl> - end of line
Example	To enter a value for setpoint 1 for the RTD=s on board 2, type: RPC 1 0.095 2<Enter> To enter a value for setpoint 2 for the RTD=s on board 1, type: RPC 2 0.998 1<Enter>

ERROR

Command	ERROR
Command Syntax	ERROR
Arguments	None
Description	Lists the errors that are stored and listed after a CLEAR. Only the first 72 errors will be listed. If more than 72 errors have occurred, the message: AERROR: Max Errors exceeded @will appear at the end of the list.
Returns	A list of errors in the following format: ERROR: error ERROR: error ERROR: error
Example	To read the contents of the Error Buffer, type: ERROR<Enter> The DTS will return the last 72 errors in the format: ERROR: QPKTS not 0 ERROR: Set parameter PPER invalid ERROR: Set parameter CLKOUT invalid ERROR: Invalid command st ERROR: AllowAnon value not 0 or 1 ERROR: AllowAnon value not found ERROR: Invalid command ist If no errors have been logged, the DTS will return: ERROR: No errors

FILL

Command	FILL
Command Syntax	FILL
Arguments	None
Description	Activates the setpoint data. If setpoints are configured, a FILL will be executed automatically at power-up. A FILL can be executed manually at any time.
Returns	<nl> - end of line
Example	To execute a FILL and activate the setpoints, type: FILL<CR>

GET PTP TIME

Command	GET PTP TIME
Command Syntax	GETTIME
Arguments	None
Description	Gets the current PTP time as used by the DTS. Time is adjusted by UTCOFFSET.
Returns	Time string in the format: Current Time year/month/day hour:minute:seconds sec xxxxxxxxxxx ns xxxxxxxxxxx
Example	To execute a GETTIME, type: GETTIME<CR> Returns: Current Time 2013/8/15 18:3:55.0 sec 1376589835 ns 633723603

GET UTC OFFSET

Command	GET UTC OFFSET
Command Syntax	GETUTCO
Arguments	None
Description	Gets the current UTC offset.
Returns	The current UTC offset in seconds, UTC updated flag and Set when UTC offset is valid in the format: Current UTC Offset <seconds> <update> <valid>
Example	To execute a GETUTCO, type: GETUTCO<CR> Returns: Current UTC Offset 0 1 0

HOST BINARY SERVER COMMAND

Command	HOST BINARY SERVER COMMAND
Command Syntax	HOST <command>
Arguments	Command - An ASCII command that would be recognized by the Host Binary Server.
Description	This command will pass a Host Binary Server command through the DTS to the Host Binary Server
Returns	<nl> - end of line

ICE POINT OFFSET ADJUSTMENT

Command	ICE POINT OFFSET ADJUSTMENT
Command Syntax	IPO <start channel> <end channel>
Arguments	<start channel> - the first channel to be adjusted. <end channel> - the last channel to be adjusted
Description	Commands the DTS to calculate and adjust the offset settings for the channels specified. If an end channel is not specified, only the start channel will be modified. This command assumes that 0 degrees C is applied to the specified channels. A SAVE command must be issued when this command is completed to make the changes permanent
Returns	<nl> - end of line

LIST BOOTLOADER GROUP VARIABLES

Command	LIST BOOTLOADER GROUP VARIABLES
Command Syntax	LIST IP
Arguments	None
Description	Lists the variables for the bootloader configuration from the Group IP.
Returns	SET IPADD <var> SET SUBNET <var> SET MAC <var> SET LOGIN <var> SET PASSWORD <var> SET LOGIN1 <var> SET PASSWORD1 <var> SET ALLOWANON <var> SET APP <var> SET GW <var> <var> - variable
Example	To view the current Bootloader Group variable settings, type: LIST IP <CR> The DTS4050 will return the current bootloader variable settings, The could appear as follows: SET IPADD 191.30.41.104 SET SUBNET 255.255.0.0 SET MAC 000.096.093.400.000.103 SET LOGIN Scanivalve SET PASSWORD Scanner SET LOGIN1 Scanivalve1 SET PASSWORD1 Scanner1 SET ALLOWANON 1 SET APP Dts4000.hex SET GW 10.0.0.1
Notes	The variables in this group are NOT saved when a SAVE command is issued. They may be only saved by using the SAVEIP command.

LIST CALIBRATION

Command	LIST CALIBRATION
Command Syntax	LIST C
Arguments	None
Description	Lists the calibration configuration variables.
Returns	SET NUMCOEF <var> SET NUMPTS <var> SET CALAVG <var> SET NUMTEMP <var> <var> - variable
Example	To view the calibration configuration variable settings, type: LIST C<CR> The DTS will return the calibration configuration variable settings, such as: SET NUMCOEF 3 SET NUMPTS 8 SET CALAVG 4 SET NUMTEMP 0

LIST CHANNEL CORRECTION SETPOINTS

Command	LIST CHANNEL CORRECTION SETPOINTS
Command Syntax	LIST P <channel>
Arguments	Channel - is any valid channel number from 0 to 16, 32 or 64 depending on the module type.
Description	Lists the calibration setpoints for the channel listed. If channel 0 is specified, the setpoints for all channels will be listed.
Returns	<pre>SET PT 1 0 <var1> <var2> SET PT 1 1 <var1> <var2> SET PT 1 2 <var1> <var2> SET PT 1 3 <var1> <var2> SET PT 1 4 <var1> <var2> SET PT 1 5 <var1> <var2> SET PT 1 6 <var1> <var2> SET PT 1 7 <var1> <var2></pre> <p><var> - variable</p>
Example	<p>To view the calibration setpoints for channel 1: Type: LIST P 1<CR> The DTS returns: SET PT 1 0 -0.010000 -275283 SET PT 1 1 0.000000 1288 SET PT 1 2 0.012000 333064 SET PT 1 3 0.024000 664759 SET PT 1 4 0.036000 996312 SET PT 1 5 0.048000 1327909 SET PT 1 6 0.060000 1659352 SET PT 1 7 0.070000 1935411</p>
Notes	<p>The values shown here are values a typical one module. The actual calibration setpoints in a different module may be different.</p> <p>This syntax is used only when NUMTEMPS is set to 0.</p>

LIST CHANNEL CORRECTION SETPOINTS (MULTI-TEMPERATURE CALIBRATION)

Command	LIST CHANNEL CORRECTION SETPOINTS (Multi-Temperature Calibration)
Command Syntax	LIST P [<type> <chan/board> <temp>]
Arguments	Type - T/C or RTD Chan/board - A single channel, 1 to 64 for T/C or 1 to 4 for RTD. A range of channels; start chan..end chan. Temp - a single temp, a range of temperature indexes; start temp..end temp.
Description	Lists the calibration setpoints with the following conditions: 1. If no variables are specified, the setpoints for all T/C and RTD channels will be listed. 2. If only T or R is specified, all T/C or all RTD channels will be listed. 3. If T or R and chan/board are specified, a single channel or range of channels for T/Cs or RTDs will be specified. 4. If T or R and chan/board and temp are specified, a single channel or range of channels, and a single temperature or range of temperatures
Example	<p>To view the calibration setpoints for RTD channel 1 at 23 degrees C, type: LIST P R 1 23<CR> The DTS returns: SET PT 1 0 -0.010000 -275283</p>
Notes	<p>The values shown here are values a typical one module. The actual calibration setpoints in a different module may be different.</p> <p>This syntax is used only when NUMTEMPS is set to 1 or greater.</p>

LIST CHANNEL DEFINITIONS

Command	LIST CHANNEL DEFINITIONS
Command Syntax	LIST DEF <channel>
Arguments	Channel - is a valid channel number 1 through 64, depending on the module type.
Description	Lists the channel definitions for the specified channel. Only one channel may be specified at a time because of the size of the returned ASCII string. The definition for each channel may be 2048 bytes
Example	<p>To view the calibration setpoints for channel 1, type: LIST DEF 1<CR> The DTS returns: SET DEF 1 < ASCII String up to 2048 bytes></p>

LIST CONFIGURATION VARIABLES

Command	LIST CONFIGURATION VARIABLES
Command Syntax	LIST A
Arguments	None
Description	Lists all of the configuration variables including calibration coefficients.
Example	<p>To view or log the configuration variables, type: LIST A<CR> The DTS will return all configuration variables.</p>

LIST FILES

Command	LIST FILES
Command Syntax	DIR
Arguments	None
Description	Lists the data files stored in the DTS4050 folder on the DTS4050 system flash chip.
Example	To list all data files stored on the DTS4050 system computer drive, type: DIRFILE<CR> The DTS will return a file list, typically similar to: <pre>-rw-r--r-- 11 217 Aug 1 2008 ip.cfg -rw-r--r-- 11 340999 Aug 1 2008 DTS4000.BIT -rw-r--r-- 11 610058 Aug 1 2008 Dts4000.hex -rw-r--r-- 11 221 Aug 1 2008 ptp.cfg -rw-r--r-- 11 25 Aug 1 2008 hw.cfg</pre>

LIST GAIN

Command	LIST GAIN
Command Syntax	LIST G
Arguments	None
Description	Lists the thermocouple gain correction assigned to the channel listed.
Example	To view the thermocouple gain settings in a 16 channel module, type: LIST G <CR> The DTS will return all of the thermocouple gain settings. They could appear as follows. <pre>SET GAIN 1 1.11 SET GAIN 2 1.01 SET GAIN 3 0.98 : : : : : : : : : : : : SET GAIN 13 1.06 SET GAIN 14 1.00 SET GAIN 15 0.99 SET GAIN 16 1.10</pre>

LIST IDENTIFICATION

Command	LIST IDENTIFICATION
Command Syntax	LIST I
Arguments	None
Description	Lists the IDENTIFICATION configuration variables.
Example	To verify the general module configuration settings, type: LIST I<CR> The DTS will return: <pre>SET ECHO 0 SET AUTOCON 0 SET HOST 0 0 T SET HOSTCMD 0 SET TCMAXSLEW 50000 SET RTDMAXSLEW 64000 SET TITLE1 DTS4050/32Tx SET TITLE2 Version 1.00 SET PORT 0</pre>

LIST LABELS

Command	LIST LABELS
Command Syntax	LIST LA
Arguments	None
Description	Lists the user-definable channel labels.
Example	To view the channel labels, type: LIST LA<CR> The DTS will return: <pre>SET LABEL 1 T/C1 SET LABEL 2 T/C2 SET LABEL 3 T/C3 : : : : : : : : : : : : SET LABEL 14 T/C14 SET LABEL 15 T/C15 SET LABEL 16 T/C16</pre>

LIST LIMITS

Command	LIST LIMITS
Command Syntax	LIST LI
Arguments	None
Description	Lists the channel high and low limits for alarms
Example	To verify the channel limit settings for a 16 channel module, type: LIST LI<CR> The DTS will return: <pre> SET LIMIT 1 1 500.00 -50.00 SET LIMIT 2 1 500.00 -50.00 SET LIMIT 3 1 500.00 -50.00 : SET LIMIT 13 1 500.00 -50.00 SET LIMIT 14 1 500.00 -50.00 SET LIMIT 15 1 500.00 -50.00 SET LIMIT 16 1 500.00 -50.00 </pre>

LIST NETWORK IDENTIFICATION

Command	LIST IDENTIFICATION
Command Syntax	LIST ID
Arguments	None
Description	Lists the MODULE NETWORK IDENTIFICATION configuration variables to support the Network ID command.
Example	To verify the Network Identification configuration settings, type: LIST ID<CR> The DTS will return: <pre> SET IPADD <IP address> SET MODEL <Model/channels> SET SERNUM <Serial number> SET VER <Firmware Version> </pre>
Notes	The variable VER are listed to display current setting only. It cannot be changed by the user from the LIST ID group. The variable IPADD will only be saved after the SAVEIP command is sent. The SAVE command will not save the IPADD variable.

LIST OFFSET

Command	LIST OFFSET
Command Syntax	LIST O
Arguments	None
Description	Lists the thermocouple offset correction assigned to the channel specified. The OFFSET values are A/D counts.
Example	To view all of the thermocouple offset settings in a 16 channel module, type: LIST O <CR> The DTS will return the thermocouple offset settings. They could appear as follows: <pre> SET OFFSET 1 120 SET OFFSET 2 77 SET OFFSET 3 78 : : : : : : : : : : : : SET OFFSET 14 124 SET OFFSET 15 81 SET OFFSET 16 25 </pre>

LIST PRECISION TIME PROTOCOL

Command	LIST PRECISION TIME PROTOCOL
Command Syntax	LIST PTP
Arguments	None
Description	Lists the variables related to the Group PTP, Precision Time Protocol.
Example	To view all of the PTP settings, type: LIST PTP<CR> The DTS will return the current PTP settings. They typically appear as follows. <pre> SET PTPEN 0 SET TUNE 10 0.500000 500000 5 SET SLL 1 SET STAT 0 SET SST 0:0:0.000000 SET SSD 1971/1/1 SET UC 1 SET INTERVAL 100000 SET ADJDRIFFT 100 100000 SET UTCOFFSET 00:00:00 </pre>
Notes	The variables in this group are NOT saved when a SAVE command is issued. They may be only saved by using the SAVEPTP command.

LIST RTD CORRECTION VALUES

Command	LIST RTD CORRECTION VALUES
Command Syntax	LIST RPC <board>
Arguments	Board - The A/D board 1, 2, 3 or 4
Description	Lists the RTD correction values
Example	<p>This command is used to verify the RTD correction values for each A/D board. To view the RTD correction values for A/D board 3, type: LIST RPC 3<CR></p> <p>The DTS will return:</p> <pre>SET RPC 3 0 0.095000 1271278 SET RPC 3 1 0.100000 1338897 SET RPC 3 2 0.105000 1406643 SET RPC 3 3 0.110000 1474311 SET RPC 3 4 0.115000 1542011 SET RPC 3 5 0.120000 1609718 SET RPC 3 6 0.125000 1677418 SET RPC 3 7 0.131000 1758718</pre>
Notes	The values shown here are values for a standard module. The actual calibration setpoints for another module may be different.

LIST RTD CONVERSION VALUES

Command	LIST RTD CONVERSION VALUES
Command Syntax	LIST RTDP
Arguments	None
Description	Lists the RTD conversion values for all RTD channels. There will be two values for a 16 channel module, 4 values for a 32 channel module and 8 values for a 64 channel module
Example	<p>This command is used to verify the RTD correction values of the DTS, type: LIST RTD<CR></p> <p>A 64 channel DTS may return:</p> <pre>SET RTD 1 100.0000 3.908e-03 -5.775e-07 SET RTD 2 100.0000 3.908e-03 -5.775e-07 SET RTD 3 100.0000 3.908e-03 -5.775e-07 SET RTD 4 100.0000 3.908e-03 -5.775e-07 SET RTD 5 100.0000 3.908e-03 -5.775e-07 SET RTD 6 100.0000 3.908e-03 -5.775e-07 SET RTD 7 100.0000 3.908e-03 -5.775e-07 SET RTD 8 100.0000 3.908e-03 -5.775e-07</pre>
Notes	The values shown here are values for an ideal module. The actual calibration setpoints may be different.

LIST RTD CURRENT CONVERSION VALUES

Command	LIST RTD CURRENT CONVERSION VALUES
Command Syntax	LIST RTDX
Arguments	None
Description	Lists the RTD current conversion values for all RTD channels. There will be two values for a 16 channel module, 4 values for a 32 channel module and 8 values for a 64 channel module.
Example	<p>This command is used to verify the RTD current correction values of the DTS. This variable corrects for errors in the RTD excitation circuit.</p> <p>Type: LIST RTDX<CR></p> <p>A 64 channel DTS will return:</p> <pre>SET RTDX 1 1.0000000 SET RTDX 2 1.0000000 SET RTDX3 1.0000000 SET RTDX 4 1.0000000 SET RTDX 5 1.0000000 SET RTDX 6 1.0000000 SET RTDX7 1.0000000 SET RTDX 8 1.0000000</pre>
Notes	The values shown here are values for an ideal RTD excitation circuit. The actual values may be different.

LIST SCAN VARIABLES

Command	LIST SCAN VARIABLES
Command Syntax	LIST S
Arguments	None
Description	Lists the SCAN configuration variables.
Example	<p>This command is used to verify the general scan settings of the DTS, type: LIST S<CR></p> <p>The DTS will return:</p> <pre>SET PERIOD 1562.50000 SET AVG 4 SET FPS 0 SET XSCANTRIG 0 SET FORMAT 0 SET TIME 2 SET BIN 0 SET QPKTS 0 SET UNITS C SET RANGEV -9999.999 9999.999 SET RANGET -9999.99 9999.99 SET RATE 5.0000</pre>

LIST UTR CALIBRATION VARIABLES

Command	LIST UTR CALIBRATION VARIABLES
Command Syntax	LIST U
Arguments	None
Description	Lists the RTD calibration configuration variables
Example	This command is used to verify the calibration configuration settings of the DTS, type: LIST U<CR> The DTS will return: SET RNUMCOEF 3 SET RNUMPTS 8 SET MAXDELTA 1.000000 SET ARPCON 0 SET ARPC 1 0.000
Notes	The values shown here are values for a standard module. The actual calibration setpoints for a different module may be different. A 16 channel module will only display ARPC 1 and ARPC 2. A 32 channel module will display ARPC 1, ARPC 2, ARPC 3 and ARPC 4. A 64 channel module will display ARPC 1, ARPC 2, ARPC 3, ARPC 4, ARPC 5, ARPC 6, ARPC 7 and ARPC 8.

OPEN THERMOCOUPLE TEST

Command	OPEN THERMOCOUPLE TEST
Command Syntax	OTC
Arguments	None
Description	Commands the DTS to test for open thermocouples. The command causes a small current to be applied to each thermocouple. If a thermocouple is found to be open, an error is logged and bit 12 in the channel status element of the data packet is set to a 1 (1000Hex). Also, the channel status code for an open channel will be 2000 if scanning with FORMAT set to 0. This command is NOT performed automatically at power up.
Example	To test for open thermocouples, type: OTC<CR> To see the results of the test, type: ERROR<CR> If any thermocouple circuits are found open, an error will be logged in the error log.

CLEAR ACCUMULATED PTP DATA

Command	CLEAR ACCUMULATED PTP DATA
Command Syntax	PTPCLEAR
Arguments	None
Description	Clears the accumulated data in the histogram buffers and restarts sampling.
Example	To clear the accumulated data from the histogram buffer, type: PTPCLEAR<CR> The DTS module will return: <nl>

DISPLAY PTP STATISTICS

Command	DISPLAY PTP STATISTICS
Command Syntax	PTPSTAT
Arguments	None
Description	Displays the accumulated data in histogram form.
Returns	The histogram output is in the form: OFM, INTERVAL, <interval value>, <interval -6>, <interval -5>, <interval -4>, <interval -3>, <interval -2>, <interval -1>, <interval 0>, <interval 1>, <interval 2>, <interval 3>, <interval 4>, <interval 5>, <interval 6>
Example	To display the PTP statistics, type: PTPSTAT<CR> The DTS will return: OFM, INTERVAL, 100000, 114, 13, 10, 23, 21, 15, 36, 6, 12, 9, 23, 10, 129

REBOOT

Command	REBOOT
Command Syntax	REBOOT RESTART (optional)
Arguments	None
Description	Commands the DTS to reboot. Any coefficients and configuration variables that have not been saved will be reset to the last saved values.
Example	To reboot from the network, type: REBOOT<CR>
Notes	The RESTART and the REBOOT command are identical and perform the same task

SAVE

Command	SAVE
Command Syntax	SAVE
Arguments	None
Description	Commands the DTS to save the RAM image of Non Volatile Memory(NVM). Any change to a configuration variable must be followed by a SAVE command if the change is to be permanent.
Returns	<nl> - end of line.
Example	To save the current configuration variable settings and conversion coefficients, type: SAVE<CR>

SAVE BOOTLOADER VARIABLES

Command	SAVE BOOTLOADER VARIABLES
Command Syntax	SAVEIP
Arguments	None
Description	Commands the DTS to save the current settings for the LIST IP variables from RAM into Non Volatile Memory (NVM). Any change to a configuration variable in the LIST IP group must be followed by a SAVEIP command if the change is to be permanent.
Returns	“WARNING: This action could cause network communication problem. Type SAVEIPCONFIRM to confirm the changes to the LIST IP group, or STOP to cancel the operation” <nl> - End of line.
Example	To save the current configuration of the LIST IP variables, type: SAVEIP<CR> The software will return the following message: “WARNING: This action could cause network communication problem. Type SAVEIPCONFIRM to confirm the changes to the LIST IP group, or STOP to cancel the operation” Type: SAVEIPCONFIRM<CR> to complete the save.
Notes	Changes to the bootloader configuration variables will not take effect until power is cycled, or a REBOOT command is issued. The SAVEIP command may require approximately 5 seconds to complete, depending on the configuration. DO NOT issue a RESTART command, or cycle power during this time. The SAVEIP operation has been completed when a caret (>) is returned. Normally, commands entered during this time would be ignored, but it is possible on rare occasions to cause the DTS4050 firmware to freeze.

SAVE PTP VARIABLES

Command	SAVE PTP VARIABLES
Command Syntax	SAVEPTP
Arguments	None
Description	Commands the DTS to save the current settings for the LIST PTP variables from RAM into Non Volatile Memory (NVM). Any change to a configuration variable in the LIST PTP group must be followed by a SAVEPTP command if the change is to be permanent.
Returns	<nl> - End of line.
Example	To save the current configuration settings from the LIST PTP group, type: SAVEPTP<CR>

SCAN

Command	SCAN																					
Command Syntax	SCAN																					
Arguments	None																					
Description	Commands the DTS to scan the pressure sensors and send Scan packets to the client. Data are returned immediately if XSCANTRIG is set to 0. If XSCANTRIG is set to 1, data will be returned after a hardware trigger, or a software trigger. For more information on software triggers, refer to the SCAN TRIGGER command. For Hardware trigger requirements, refer to the Trigger Requirements section.																					
Returns	Scan data formatted by the setting of EU, BIN, and FORMAT. Refer to the examples for more information. When FORMAT is set to 0, a channel status code will be returned with the data for each channel. If multiple errors exist the code with the highest priority will be the only code displayed <table border="1" data-bbox="2138 655 2778 933"> <thead> <tr> <th>Status Code</th> <th>Description</th> <th>Priority</th> </tr> </thead> <tbody> <tr> <td>1000</td> <td>Channel A/D is disabled</td> <td>1</td> </tr> <tr> <td>2000</td> <td>Channel T/C is open</td> <td>2</td> </tr> <tr> <td>3000</td> <td>Channel is over range</td> <td>3</td> </tr> <tr> <td>4000</td> <td>Channel is under range</td> <td>4</td> </tr> <tr> <td>5000</td> <td>Channel is over limit</td> <td>5</td> </tr> <tr> <td>6000</td> <td>Channel is under limit</td> <td>6</td> </tr> </tbody> </table>	Status Code	Description	Priority	1000	Channel A/D is disabled	1	2000	Channel T/C is open	2	3000	Channel is over range	3	4000	Channel is under range	4	5000	Channel is over limit	5	6000	Channel is under limit	6
Status Code	Description	Priority																				
1000	Channel A/D is disabled	1																				
2000	Channel T/C is open	2																				
3000	Channel is over range	3																				
4000	Channel is under range	4																				
5000	Channel is over limit	5																				
6000	Channel is under limit	6																				
...continued...																						

Example	<p>EXAMPLE 1 EU = 1 BIN = 0 FORMAT = 0. Data is scrolled and will be displayed as follows: Frame # <number> Time <time> <μs or ms> Rtd1 <temp> : : RtdMax <temp> Units <unit> <chan 1> <temp eu> <channel status code> : : : <chan Max> <temp eu> <channel status code></p> <p>EXAMPLE 2 EU = 0 BIN = 0 FORMAT = 0 Data is scrolled and will be displayed as follows: Frame # <number> Time <time> <μs or ms> Rtd1 <temp counts> RtdMax <temp counts> Units <unit> <chan 1> <temp counts> <channel status code> : : : <chan Max> <temp counts> <channel status code></p> <p>EXAMPLE 3 EU = 1 BIN = 0 FORMAT = 1 Data is scrolled in place and will be displayed as follows: Frame = <number> Time = <time> <μs or ms> Units = <unit> RTD1 <temp> RTDMax <temp> <chan> <temp eu> <chan><temp eu> <chan> <temp eu> <chan> <temp eu> <chan> <temp eu> <chan><temp eu> <chan> <temp eu> <chan> <temp eu> <chan> <temp eu> <chan><temp eu> <chan> <temp eu> <chan> <temp eu> : : : : : : : <chan> <temp eu> <chan><temp eu> <chan> <temp eu> <chan> <temp eu></p> <p>EXAMPLE 4 EU = 0 BIN = 0 FORMAT = 1 Data is scrolled and will be displayed as follows: Frame = <number> Time = <time> <μs or ms> Units = <unit> RTD1 <counts>.....RTDMax <counts> <chan> <temp cts> <chan><temp cts> <chan> <temp cts> <chan> <temp cts> <chan> <temp cts> <chan><temp cts> <chan> <temp cts> <chan> <temp cts> <chan> <temp cts> <chan><temp cts> <chan> <temp cts> <chan> <temp cts> : : : : : : : <chan> <temp cts> <chan><temp cts> <chan> <temp cts> <chan> <temp cts></p>
...continued...	

Notes	<p>The DTS4050 will use the current PTP time as the scan start time under two conditions: 1) When the PTP system is disabled via the SET PTPEN 0 command. 2) When the current time has not been received from the PTP server since the DTS was powered up. Under this condition the DTS 4050 time will start at Jan 1 1970, 0:00:00.000 hours, or epoch 0 time. This most likely will happen when there is no PTP server on the network. If the DTS was enabled and then disabled after receiving a time set from the PTP time server, the DTS will keep time from the last clock setting from the PTP server. When these two cases are not met, the DTS 4050 uses the start time set via the SET SST <time> and SET SSD <date> setting in the PTP group.</p>
--------------	--

SCAN TRIGGER

Command	SCAN TRIGGER
Command Syntax	TRIG
Arguments	None
Description	This command acts as a software trigger to the DTS. When XSCANTRIG is set to 1, an averaged frame of data will be output when the DTS receives the TRIG command or a <TAB> character code (9 HEX or Control I). This will continue until a STOP command is issued or the Frames per Scan variable is met. The data format will depend upon the setting of EU, BIN and FORMAT.
Example	<p>A scan command is executed with EU set to 1, BIN set to 0, XSCANTRIG set to 1, and FORMAT set to 0. The DTS will wait for a Hardware trigger, the TRIG command or a <TAB> character (9 HEX or Control I). When a frame is triggered, the data is scrolled and will be displayed as follows:</p> <pre> Frame # <number> Time <time> <μs or ms> Rtd1 <temp> : : RtdMax <temp> Units <unit> <chan 1> <temp eu> <channel status code> : : : <chan Max> <temp eu> <channel status code> </pre> <p>For information on other formats, refer to the "Scan" on page 45.</p>

SET

Command	SET
Command Syntax	SET <name> <value>
Arguments	<name> - the Configuration Variable to be set or modified. <value> - the value of that Configuration Variable
Description	Commands the DTS to set one of the many Configuration Variables. Configuration Variables are described in a subsequent section.
Returns	variable
Notes	Listing the Configuration Variables with the LIST command outputs the data in the format required by the SET command. This enables the user to upload data from a file that has been created by a LIST download.

STATUS

Command	STATUS																						
Command Syntax	STATUS																						
Arguments	None																						
Description	<p>Commands the DTS to send a Status Packet to the client. The Status Packet is described in a subsequent section.</p> <p>The STATUS command may be entered at any time. This is one of the commands that will not generate an error if entered while the DTS is not READY. The DTS could return one of the following status descriptions:</p> <table border="0"> <tr> <td>ADCAL</td> <td>The DTS is calibrating the A/D converters</td> </tr> <tr> <td>CAL</td> <td>The DTS is executing a PT or RPT command</td> </tr> <tr> <td>INVALID</td> <td>The DTS is in an INVALID operating mode.</td> </tr> <tr> <td>LIST</td> <td>The DTS is outputting a configuration variable LIST</td> </tr> <tr> <td>OTC</td> <td>The DTS is testing for open thermocouples</td> </tr> <tr> <td>PERIOD</td> <td>The DTS is executing a SET PERIOD command</td> </tr> <tr> <td>READY</td> <td>The DTS is operating and ready to accept a command.</td> </tr> <tr> <td>SAVE</td> <td>The DTS is SAVING a configuration</td> </tr> <tr> <td>SCAN</td> <td>The DTS is in the SCAN mode.</td> </tr> <tr> <td>TYPE</td> <td>The DTS is setting the thermocouple type</td> </tr> <tr> <td>UPLOAD</td> <td>The DTS is UPLOADING a file.</td> </tr> </table>	ADCAL	The DTS is calibrating the A/D converters	CAL	The DTS is executing a PT or RPT command	INVALID	The DTS is in an INVALID operating mode.	LIST	The DTS is outputting a configuration variable LIST	OTC	The DTS is testing for open thermocouples	PERIOD	The DTS is executing a SET PERIOD command	READY	The DTS is operating and ready to accept a command.	SAVE	The DTS is SAVING a configuration	SCAN	The DTS is in the SCAN mode.	TYPE	The DTS is setting the thermocouple type	UPLOAD	The DTS is UPLOADING a file.
ADCAL	The DTS is calibrating the A/D converters																						
CAL	The DTS is executing a PT or RPT command																						
INVALID	The DTS is in an INVALID operating mode.																						
LIST	The DTS is outputting a configuration variable LIST																						
OTC	The DTS is testing for open thermocouples																						
PERIOD	The DTS is executing a SET PERIOD command																						
READY	The DTS is operating and ready to accept a command.																						
SAVE	The DTS is SAVING a configuration																						
SCAN	The DTS is in the SCAN mode.																						
TYPE	The DTS is setting the thermocouple type																						
UPLOAD	The DTS is UPLOADING a file.																						
Example	<p>If the STATUS command is entered while the DTS is on, but inactive, the DTS will return: Status: READY</p> <p>If the STATUS command is entered while the DTS is executing a SAVE command, the DTS will return: Status: SAVE</p>																						

STOP

Command	STOP
Command Syntax	STOP
Arguments	None
Description	Commands the DTS to abort the current operation and go into the READY mode.
Notes	

VERSION

Command	VERSION
Command Syntax	VER
Arguments	None
Description	Requests the version number of the DTS4000.hex firmware file.
Example	<p>To read the current software version in a 64 channel module, type: VER<CR> The DTS returns: Version: DTS Scanivalve © 2004-2013 Ver 1.00 32 Channels H/W Ver 9</p>

CONFIGURATION VARIABLES

Configuration Variables control the way the DTS functions. The Variables are assigned to one of several groups:

SCAN(S)	PRECISION TIME PROTOCOL (PTP)	THERMOCOUPLE(T)
IDENTIFICATION(I)	CHANNEL CORRECTION(P)	RTD CORRECTION(RPC)
NETWORK IDENTIFICATION(ID)	GAIN(G)	RTD CONVERSION(RTDP)
BOOTLOADER (IP)	OFFSET(O)	RTD CALIBRATION(U)
CHANNEL DEFINITION(DEF)	LABELS(LA)	
CALIBRATION(C)	LIMIT(LI)	

Each variable is assigned a “data type” description.

SCAN VARIABLES (LIST S)

AVERAGE (AVG)

VARIABLE	AVG <value>
VALID VALUES	1 to 240
DEFAULT VALUE	4
DATA TYPE	integer
DESCRIPTION	This sets the number of raw samples to acquire before producing a filtered output.

BINARY (BIN)

VARIABLE	BIN <value>
VALID VALUES	0 or 1
DEFAULT VALUE	0
DATA TYPE	integer
DESCRIPTION	<p>Sets the format of the data packet output.</p> <p>1 = Binary 0 = ASCII</p>

FORMAT (FORMAT)

VARIABLE	FORMAT <value>
VALID VALUES	0 or 1
DEFAULT VALUE	0
DATA TYPE	integer
DESCRIPTION	<p>Determines if data are to be scrolled on the display. ASCII Output only</p> <p>0 - data are scrolled 1 - data are displayed in place, formatted for a VT100 terminal.</p>

FRAMES PER SCAN (FPS)

VARIABLE	FPS <value>
VALID VALUES	0 to 4294967295
DEFAULT VALUE	0
DATA TYPE	long integer
DESCRIPTION	Sets the number of averaged frames to send to the client. If a 0 is entered, the scan will continue until a STOP command is received.

PERIOD (PERIOD)

VARIABLE	PERIOD <value>
VALID VALUES	781 to 262144 μsec (64 Channel versions) 781 to 524288 μsec (32 Channel Versions) 781 to 1048576 μsec (16 Channel Versions)
DEFAULT VALUE	7812
DATA TYPE	float
DESCRIPTION	Sets the interval between channel samples (inter-channel delay). The maximum settings for each version represent the rate limits when AVG is set to 1. The rate limits are: 16 Channels - 80 Hz/Channel 32 Channels - 40 Hz/Channel 64 Channels - 20 Hz/Channel

QPKTS (QPKTS)

VARIABLE	QPKTS <value>
VALID VALUES	0
DEFAULT VALUE	0
DATA TYPE	integer
DESCRIPTION	This is a non-functioning variable left in place for legacy compatibility.

TEMPERATURE RANGE OVER RANGE VALUES (RANGET)

VARIABLE	RANGET <low range temp value> <high range temp value>
VALID VALUES	-9999.99 to 9999.99
DEFAULT VALUE	Low range temp value - -9999.99 High range temp value - 9999.99
DATA TYPE	integer
DESCRIPTION	Sets the output when units is set to a temperature and the high and/or low range limits are exceeded. When a channel exceeds the low limit, the data display will be setting of the low range value and the channel status code will indicate 4000. When the high limit is exceeded, the data display will be setting of the high range value and the channel status code will indicate 3000.

VOLTAGE RANGE OVER RANGE VALUES (RANGEV)

VARIABLE	RANGEV <low range volt value> <high range volt value>
VALID VALUES	-9999.99 to 9999.99
DEFAULT VALUE	Low range temp value - -9999.99 High range temp value - 9999.99
DATA TYPE	integer
DESCRIPTION	Sets the output when units is set to volts and the high and/or low range limits are exceeded. When a channel exceeds the low limit, the data display will be setting of the low range value and the channel status code will indicate 4000. When the high limit is exceeded, the data display will be setting of the high range value and the channel status code will indicate 3000.

SCAN RATE (RATE)

VARIABLE	RATE <value>
VALID VALUES	.01 to 80 (16 channel), .01 to 40 (32 channel), .01 to 20 (64 channel)
DEFAULT VALUE	Depends on the number of channels
DATA TYPE	float
DESCRIPTION	Calculates and modifies the setting of PERIOD to give a data output rate in samples per channel per second. The setting of AVG is included in the calculation but is not modified. Conversely, if PERIOD is modified, RATE will be updated to show the data rate based on that setting of PERIOD. If AVG is modified, the value of RATE will be updated to show the new data rate, but PERIOD will not be modified. If the calculated RATE exceeds the maximum allowed for a DTS Version, the rate will not change and an ERROR will be logged. The maximum rate for each version is: 16 Channel - 80 Hz/Channel 32 Channel - 40 Hz/Channel 64 Channel - 20 Hz/Channel Rate is calculated by the formula: Data Rate = $\frac{1}{\text{Period} \times \text{Number of Channels} \times \text{Average}}$

UNITS (UNITS)

VARIABLE	UNITS <value>
VALID VALUES	see "description"
DEFAULT VALUE	0
DATA TYPE	string
DESCRIPTION	Engineering Unit conversion type. This can be : A - Volts (Vdc) corrected by the RTD voltage C - degrees Celsius (°C) F - degrees Fahrenheit (°F), K - Kelvin (°K) M - Mixed (T/C data in raw, RTD data in °C) R - Rankin (°R) V - Volts (Vdc) Raw uncorrected 0 - Zero (Raw Counts)
NOTES	The setting of UNITS affects the RTD temperature units. ASCII Output (BIN = 0): When UNITS is set to 0, the RTD temperature is in A/D counts. When UNITS is set to A, C, F, K, R or V the RTD temperature is in degrees C. Binary Output (BIN = 1): When UNITS is set to 0, the RTD temperature is in A/D counts When UNITS is set to any other value, the RTD temperature is in °C.

SCAN TRIGGER (XSCANTRIG)

VARIABLE	XSCANTRIG <code>
VALID VALUES	0 to 254
DEFAULT VALUE	0
DATA TYPE	integer
DESCRIPTION	Sets the External Trigger as the Frame Trigger. 0 - The internal clock is the frame trigger 1 - The external trigger is the frame trigger 2 to 254 - The external trigger is the frame trigger. The external trigger timing will be divided by the number entered.
NOTES	The External Trigger may be a hardware trigger or a Software Trigger. The hardware trigger is a pulse 4.5 to 15 volts at 6.5 mA. The software trigger is a Tab(Control I) character. EXAMPLE: If XSCANTRIG is set to 2, the triggering will be whatever the input rate is divided by 2. If the trigger rate is 10 Hz, the DTS will be triggered at a 5 Hz rate. If XSCANTRIG is set to 10 and the trigger rate is 10 Hz, the DTS will be triggered at a 1 Hz rate.

CHANNEL CORRECTION VARIABLES (LIST P)

NOTE: The PT variable on this page is used only if NUMTEMPS is set to 0. If NUMTEMPS is set to 1 or greater, the PT variable on the next page should be used. Please refer to the description of the NUMTEMPS variable in the Calibration Variable Group for more detailed information on THE NUMTEMPS variable.

PT (PT)

VARIABLE	PT <channel> <index> <volts applied> <counts applied>
VALID VALUES	Channel - 0 to 16, 32 or 64 Index - 0 to 7 Volts Applied - any valid number Counts Applied - any valid number
DEFAULT VALUE	Channel - 0 Index - 0 Volts Applied - 0 Counts Applied - 0
DATA TYPE	Channel - Integer Index - Integer Volts Applied - float Counts Applied - Integer
DESCRIPTION	This is the list of setpoints used to calibrate each channel. If zero (0) is entered, all channels will be returned.
NOTES	The PT variable on this page is used only if NUMTEMPS is set to 1 or greater. If NUMTEMPS is set to 0, the PT variable on the previous page should be used. Please refer to the description of the NUMTEMPS variable in the Calibration Variable Group for more detailed information on THE NUM-TEMPS variable. EXAMPLE The List P command is used to view these variables. The variables for each channel are set before the initial factory calibration. To list the values for channel 2, type: LIST P 2<Enter> The DTS will return: SET PT 2 0 0.010000 276468 SET PT 2 1 0.000000 517 SET PT 2 2 0.012000 332795 SET PT 2 3 0.024000 664988 SET PT 2 4 0.036000 997039 SET PT 2 5 0.048000 1329141 SET PT 2 6 0.060000 1661087 SET PT 2 7 0.070000 1937569 The values shown here are values for a standard module. The actual calibration setpoints for a given module may be different.

PT <TYPE> (PT <TYPE>)

VARIABLE	PT <type> <chan/board> <temp ndx> <temp> <pt ndx> <act volts> <counts>	
VALID VALUES	Type	- T (for T/C) or R (for RTD)
	Chan/board	- A single channel, 1 to 64 for T/C or 1 to 4 for RTD A range of channels, start chan..end chan
	Temp ndx	- The temperature index from 1 to NUMTEMPS
	Pt ndx	- The index of this point from 1 to NUMPTS
	Act volts	- The actual applied volts
	Counts	- The A/D counts at this point
DEFAULT VALUE	Type	- T
	Chan/board	- 1
	Temp ndx	- 5
	Pt ndx	- 5
	Act volts	- 0
	Counts	- 0
DATA TYPE	Type	- char
	Chan/board	- string
	Temp ndx	- integer
	Pt ndx	- integer
	Act volts	- float
	Counts	- integer
DESCRIPTION	This is the list of setpoints used to calibrate each channel.	
NOTES	<p>EXAMPLE</p> <p>The List P command is used to view these variables. The variables for each channel are set before the initial factory calibration. To list the values for RTD channel 2at 23 degrees C, type: LIST P R 2 23<Enter></p> <p>The DTS will return: SET PT R 2 3 23 3 .256 276468</p> <p>NOTE: The values shown here are values for a typical module. The actual calibration setpoints for a given module may be different.</p>	

IDENTIFICATION VARIABLES (LIST I)

AUTO CONNECT (AUTOCON)

VARIABLE	AUTOCON <code>
VALID VALUES	0 or 1
DEFAULT VALUE	0
DATA TYPE	integer
DESCRIPTION	Determines if the DTS will automatically connect to a binary receiver. 0 - the DTS will not automatically convert. 1 - the DTS will automatically convert.

ECHO (ECHO)

VARIABLE	ECHO <code>
VALID VALUES	0 or 1
DEFAULT VALUE	0
DATA TYPE	integer
DESCRIPTION	Determines if characters received from an Ethernet host will be echoed back to the host. 0 - the DTS will not echo characters 1 - the DTS will echo characters back to the host.

HOST (HOST)

VARIABLE	HOST <IP address> <port> <protocol>
VALID VALUES	IP Address - Any valid IP address Port - Any valid Port Protocol - T = TCP U = UDP
DEFAULT VALUE	IP Address - 0 Port - 0 Protocol - T
DATA TYPE	varies
DESCRIPTION	Sets the value of the IP address and port number for binary data for the host computer. If IP Address and Port are set to 0, Binary data are sent out over the TelNet Port. If a server address and port number are defined, Binary data are sent out over that port.

HOST COMMAND (HOSTCMD)

VARIABLE	HOSTCMD <ASCII string>
VALID VALUES	any valid host command string
DEFAULT VALUE	0
DATA TYPE	ASCII Strings
DESCRIPTION	Sends the ASCII command string contained in this variable to the host computer binary receiver.

PORT (PORT)

VARIABLE	PORT <value>
VALID VALUES	0
DEFAULT VALUE	0
DATA TYPE	integer
DESCRIPTION	Sets the Ethernet port. With PORT set to 0, it uses the default value, 23 which is the TelNet port.

RTD MAXIMUM SLEW LIMIT (RTDMAXSLEW)

VARIABLE	RTDMAXSLEW <value>
VALID VALUES	0 to 32000
DEFAULT VALUE	0
DATA TYPE	integer
DESCRIPTION	This is a non-functional variable left in place for legacy compatibility

THERMOCOUPLE MAXIMUM SLEW LIMIT (TCMAXSLEW)

VARIABLE	TCMAXSLEW <value>
VALID VALUES	0 to 3000000
DEFAULT VALUE	0
DATA TYPE	integer
DESCRIPTION	This is a non-functional variable left in place for legacy compatibility

TITLE 1 (TITLE1)

VARIABLE	TITLE1 <title>
VALID VALUES	any valid ASCII string up to 255 characters
DEFAULT VALUE	Scanivalve DTS4000
DATA TYPE	ASCII String
DESCRIPTION	Sets the value of Title number 1.

TITLE 2 (TITLE2)

VARIABLE	TITLE2 <title>
VALID VALUES	any valid ASCII string up to 255 characters
DEFAULT VALUE	The current software version
DATA TYPE	ASCII String
DESCRIPTION	Sets the value of Title number 2.

BOOTLOADER VARIABLES (LIST IP)

NOTE: The SAVE command does not save any variables in the LIST IP group. In order to save any changes to non-volatile memory, the SAVEIP command must be issued. See "Save Bootloader Variables" on page 44 for more information on the SAVEIP command.

DTS4050 IP ADDRESS (IPADD)

VARIABLE	IPADD <value>
VALID VALUES	any valid IP address
DEFAULT VALUE	191.30.100.XXX – 16 channel units 191.30.105.XXX – 32 channel units 191.30.110.XXX – 64 channel units *where XXX is the serial number of the unit
DATA TYPE	integer
DESCRIPTION	The IP address of the module.

DTS4050 SUBNET MASK (SUBNET)

VARIABLE	SUBNET <value>
VALID VALUES	any valid Subnet Mask
DEFAULT VALUE	255.255.0.0
DATA TYPE	integer
DESCRIPTION	The Subnet mask for the module. The subnet mask must be configured for the network where the DTS module will be connected.

DTS4050 MAC ADDRESS (MAC)

VARIABLE	MAC <value>
VALID VALUES	000.096.093.XXX.YYY.ZZZ
DEFAULT VALUE	000.096.093.100.XXX.XXX – 16 channel units 000.096.093.105.XXX.XXX – 32 channel units 000.096.093.110.XXX.XXX – 64 channel units *where XXX is the serial number for the module.
DATA TYPE	integer
DESCRIPTION	The MAC address of the module. The last three octets may be modified by the user, but it is recommended that they not be modified. The first three octets MUST NOT be modified, they are registered to Scanivalve.

LOGIN (LOGIN)

VARIABLE	LOGIN <value>
VALID VALUES	any valid character string
DEFAULT VALUE	Scanivalve
DATA TYPE	string
DESCRIPTION	The username for the FTP login.

PASSWORD (PASSWORD)

VARIABLE	PASSWORD <value>
VALID VALUES	any valid character string
DEFAULT VALUE	Scanner
DATA TYPE	string
DESCRIPTION	The password associated with the user name for the FTP login.

LOGIN 1 (LOGIN1)

VARIABLE	LOGIN1 <value>
VALID VALUES	any valid character string
DEFAULT VALUE	Scanivalve1
DATA TYPE	string
DESCRIPTION	The username for the FTP login.

PASSWORD 1 (PASSWORD1)

VARIABLE	PASSWORD <value>
VALID VALUES	any valid character string
DEFAULT VALUE	Scanner
DATA TYPE	string1
DESCRIPTION	The password associated with the user name for the FTP login.

ALLOW ANONAMOUS LOGON (ALLOWANON)

VARIABLE	ALLOWANON <value>
VALID VALUES	0 or 1
DEFAULT VALUE	0
DATA TYPE	integer
DESCRIPTION	Determines the new line character(s) for all output. 0 – Do not allow anonymous FTP logins 1 – Allow anonymous FTP logins

APPLICATION FILE (APP)

VARIABLE	APP <value>
VALID VALUES	any valid application name
DEFAULT VALUE	Dts4000.hex
DATA TYPE	string
DESCRIPTION	The file name of the application to run. This is the file name that is used when automatically running the application from the boot loader. It is also the file name used when using the RUN command. If this file is not found, an error is returned. Note that this entry is case sensitive.

GATEWAY (GW)

VARIABLE	GW <value>
VALID VALUES	any valid IP address
DEFAULT VALUE	0.0.0.0
DATA TYPE	integer
DESCRIPTION	This IP address will be used to access host with an IP address setting that is outside of the DTS subnet. This is commonly used to access an NTP server that is not in the same subnet as the DTS.

CALIBRATION VARIABLES (LIST C)

A/D CALIBRATION AVERAGING (CALAVG)

VARIABLE	CALAVG <value>
VALID VALUES	1 to 64
DEFAULT VALUE	4
DATA TYPE	integer
DESCRIPTION	Determines how much averaging to perform during an A/D Calibration. This setting will have an effect on boot up time.
NOTES	See "A/D Calibration" on page 27 for more information on the A/D Calibrations.

NUMBER OF CALIBRATION SETPOINTS (NUMPTS)

VARIABLE	NUMPTS <value>
VALID VALUES	1 to 8
DEFAULT VALUE	8
DATA TYPE	integer
DESCRIPTION	Determines the number of setpoints in the channel correction list.

NUMBER OF CALIBRATION COEFFICIENTS (NUMCOEF)

VARIABLE	NUMCOEF <value>
VALID VALUES	1 to 3
DEFAULT VALUE	3
DATA TYPE	integer
DESCRIPTION	Determines the number of calibration coefficients for the channel corrections. 1 - Offset only 2 - $y = mx + b$ correction curve 3 - $y = ax^2 + bx + c$ correction curve

NUMBER OF CALIBRATION TEMPERATURES (NUMTEMPS)

VARIABLE	NUMTEMPS <values>
VALID VALUES	0 to 8
DEFAULT VALUE	0
DATA TYPE	integer
DESCRIPTION	<p>When set to 0, module uses calibration coefficients generated during a single temperature calibration.</p> <p>If set to 1 or greater, the module uses calibration coefficients generated during a multi-temperature calibration. The following variables are relevant: PT Option And the following commands: PT Option List P Option</p>
NOTES	The value of NUMTEMPS MUST NOT be modified by an end user without detailed and specific training from Scanivalve Corp. If the value of NUMTEMPS is modified after the unit has been calibrated, ALL current calibration coefficients will be LOST .

PRECISION TIME PROTOCOL VARIABLES (LIST PTP)

PTP ENABLE (PTPEN)

VARIABLE	PTPEN <value>
VALID VALUES	0 or 1
DEFAULT VALUE	0
DATA TYPE	integer
DESCRIPTION	<p>Enables or disables the PTP engine.</p> <p>0 – disabled 1 – enabled</p>

TUNE (TUNE)

VARIABLE	TUNE <min filter depth> <clock gain> <integral limit> <median filter depth>
VALID VALUES	<p>min filter - Not range checked</p> <p>clock gain - Not range checked</p> <p>integral limit - Not range checked</p> <p>median filter - Not range checked</p>
DEFAULT VALUE	<p>min filter - 10</p> <p>clock gain - 0.5</p> <p>integral limit - 500000</p> <p>median filter - 5</p>
DATA TYPE	<p>min filter - integer</p> <p>clock gain - float</p> <p>integral limit - integer</p> <p>median filter - integer</p>
DESCRIPTION	These variables allow you to tune the PTP synch function.

SYSLOG SEVERITY LEVEL (SLL)

VARIABLE	SLL <value>
VALID VALUES	0 to 9
DEFAULT VALUE	0
DATA TYPE	integer
DESCRIPTION	<p>Sets the system log level:</p> <p>0-Off 1-Emergency 2-Alert 3-Critical 4-Error 5-Warning 6-Notice 7-Information 8-Debug level 1 9-Debug level 2</p> <p>Setting this value allows the any messages that occur with the severity level or above to be output to the device that last sent the command.</p>

STATISTICAL DATA DESTINATION (STAT)

VARIABLE	STAT <value>
VALID VALUES	0 to 9
DEFAULT VALUE	0
DATA TYPE	integer
DESCRIPTION	<p>Sets the destination of raw statistical data.</p> <ul style="list-style-type: none"> 0 – off 1 – serial 2 – network 3 – Syslog server <p>The statistical data is output in the following format: <ofm>, <msd>, <smd>, <mpd></p> <p>ofm - Offset From Master. Time that slave and master differ msd - Master to Slave Delay. Filtered packet delivery time from master to slave smd - Slave to Master Delay. Filtered packet delivery time from slave to master mpd - Mean Path Delay. Filtered mean path delay time</p>

START SCAN TIME (SST)

VARIABLE	SST <value>
VALID VALUES	Any valid time in the hh:mm:ss.ffff format
DEFAULT VALUE	12:0:0.0
DATA TYPE	integer
DESCRIPTION	Sets the hour, minute and second of the start scan time. This is referenced to the time that the grandmaster serves.
NOTES	<p>The DTS4050 will use the current PTP time as the scan start time under two conditions:</p> <ol style="list-style-type: none"> 1) When the PTP system is disabled via the SET PTPEN 0 command. 2) When the current time has not been received from the PTP server since the DTS was powered up. Under this condition the DTS 4050 time will start at Jan 1 1970, 0:00:00.000 hours, or epoch 0 time. This most likely will happen when there is no PTP server on the network. <p>If the DTS was enabled and then disabled after receiving a time set from the PTP time server, the DTS will keep time from the last clock setting from the PTP server.</p> <p>When these two cases are not met, the DTS 4050 uses the start time set via the SET SST <time> and SET SSD <date> setting in the PTP group.</p>

START SCAN DATE (SSD)

VARIABLE	SSD <value>
VALID VALUES	Any valid date in the yyyy/mm/dd format
DEFAULT VALUE	1971/1/1
DATA TYPE	integer
DESCRIPTION	Sets the year, month and day of the scan start time.

UPDATE CLOCK (UC)

VARIABLE	UC <value>
VALID VALUES	0 or 1
DEFAULT VALUE	0
DATA TYPE	integer
DESCRIPTION	Sets the switch to update the clock. When set to 0 the PTP servo runs with statistical output available but the clock rate or setting is not adjusted.

INTERVAL (INTERVAL)

VARIABLE	INTERVAL <value>
VALID VALUES	1 to 1,000,000,000
DEFAULT VALUE	5
DATA TYPE	Long Integer
DESCRIPTION	Sets the width of each histogram interval in nanoseconds.

CLOCK DRIFT ADJUSTMENT (ADJDRIIFT)

VARIABLE	ADJDRIIFT <rate> <rate limit>
VALID VALUES	Rate - Not range checked Rate limit - Not range checked
DEFAULT VALUE	Rate - 100 Rate limit - 100000
DATA TYPE	Rate - long integer Rate limit - long integer
DESCRIPTION	Sets the clock rate and clock rate limit adjustments. When the observed drift of the clock from the master is greater than the clock rate limit, or less than a negative clock rate limit, the clock rate is changed by the value in rate or negative rate, respectively.

UTC OFFSET (UTCOffset)

VARIABLE	UTCOffset <hours>:<minutes>:<seconds>
VALID VALUES	<hours> - 12 and 12 <minutes> - 0 to 59 <seconds> - 0 to 59
DEFAULT VALUE	<hours> 00 <minutes> 00 <seconds> 00
DATA TYPE	integer
DESCRIPTION	Sets the offset to be added or subtracted from the network time.

NETWORK IDENTIFICATION VARIABLES (LIST ID)**MODEL (MODEL)**

VARIABLE	MODEL <model number/channels>
VALID VALUES	Any valid model number/channel count
DEFAULT VALUE	Null
DATA TYPE	string
DESCRIPTION	Lists the module model number and channel count.

SERIAL NUMBER (SERNUM)

VARIABLE	SERNUM <serial number>
VALID VALUES	Any valid integer
DEFAULT VALUE	Null
DATA TYPE	integer
DESCRIPTION	The serial number of the module

VERSION (VER)

VARIABLE	VER <version number>
VALID VALUES	any valid integer
DEFAULT VALUE	null
DATA TYPE	integer
DESCRIPTION	The firmware version sends the ASCII command string contained in this variable to the host computer binary receiver. This variable is not settable by the user and only displays the current software version set by the current firmware.

IP ADDRESS (IPADD)

VARIABLE	IPADD <value>
VALID VALUES	any valid IP address
DEFAULT VALUE	191.30.100.XXX – 16 channel units 191.30.105.XXX – 32 channel units 191.30.110.XXX – 64channel units *where XXX is the serial number of the unit
DATA TYPE	integer
DESCRIPTION	The IP address of the module.
NOTES	This variable is not saved by the SAVE command. The SAVEIP command, followed by the SAVEIPCONFIRM command must be issued in order for any changes to be moved to non-volatile memory. This is a copy of the IPADD variable in the LIST IP group. See “Bootloader Variables (LIST IP)” on page 57 for more information on the bootloader variables.

CHANNEL IDENTIFICATION VARIABLES (LIST DEF)**CHANNEL DEFINITIONS (DEF)**

VARIABLE	DEF <channel> <definition>
VALID VALUES	Channel - the channel number Definition - any ASCII string up to 2048 bytes.
DEFAULT VALUE	Null
DATA TYPE	integer
DESCRIPTION	The variable DEF will be available for each channel in the module up to the highest channel number. The variable is intended to be used as a label or definition of the channel assignment.

LIMIT VARIABLES (LIST LI)**LIMIT (LIMIT)**

VARIABLE	LIMIT <channel> <enable> [<high limit> low limit>]
VALID VALUES	Channel - 0 to 16, 32, or 64 if 0 is entered all channels will be set. Enable - 0 disables limits 1 enables limits High limit - optional, the high limit value Low limit - optional, the low limit value
DEFAULT VALUE	Channel - 0 Enable - 0 High limit - 100 Low limit - 0
DATA TYPE	Channel - integer Enable - integer High limit - float Low limit - float
DESCRIPTION	Sets the high and low limits for each channel. When a channel exceeds the low limit, the channel status code will indicate 6000. When the high limit is exceeded, the channel status code will indicate 5000.

CHANNEL LABELS (LIST LA)**CHANNEL LABEL (LABEL)**

VARIABLE	LABEL <channel> <label>
VALID VALUES	Channel - 1 to 16, 32, or 64 Label - channel label up to 31 characters. Spaces are allowed.
DEFAULT VALUE	Channel - 1 Label - T/C <channel>
DATA TYPE	Channel - Integer Label - ASCII string
DESCRIPTION	Sets the label for each channel.

THERMOCOUPLE VARIABLES (LIST T)

THERMOCOUPLE TYPE (TYPE)

VARIABLE	TYPE <channel> <type> <shield connect>
VALID VALUES	channel - the channel number, 0 through 16, 32 or 64 type - thermocouple type shield connect - 0 or 1
DEFAULT VALUE	channel - 0 type - E, J, K, N, R, S, T shield connect - 0
DATA TYPE	channel - integer type - char shield connect - integer
DESCRIPTION	Determines the thermocouple conversion for each channel. Conversion tables for any thermocouple type can be loaded into the DTS4050's file system. The only limitation is the DTS's -15mV to 70mV calibrated range. If the channel is entered as 0, all 16 channels will be set to the thermocouple type specified. The shield connection switch should be set based on the method used to ground or shield the thermocouple. If shield connect is set to 0, the switch will be open. The default setting is 1 or closed. Refer to "Thermocouple Grounding Scenarios" on page 23 for more information.

RTD CORRECTION VARIABLES (LIST RPC)

RTD CORRECTION (RPC)

VARIABLE	RPC <board> <index> <volts applied> <counts applied>
VALID VALUES	Board - RTD board number; 1, 2, 3 or 4 Index - 0 to 7 Volts Applied - any valid number Counts Applied - any valid number
DEFAULT VALUE	Channel - 1 Index - 0 Volts Applied - 0 Counts Applied - 0
DATA TYPE	Channel - Integer Index - Integer Volts Applied - float Counts Applied - Integer
DESCRIPTION	This is the list of setpoints used to calibrate the RTD=s. Each RTD pair is corrected by the same setpoints. Each module type has one (1) RTD A/D and consequently one (1) channel for each pair of RTD=s. A 16 channel module has 1 channel, a 32 channel module has 2 channels and a 64 channel module has 4 channels.
NOTES	EXAMPLE: The List RP command is used to view these variables. The variables are set to the following before the initial factory calibration: SET RPC 1 0 0.095000 1287022 SET RPC 1 1 0.115000 1557974 SET RPC 1 2 0.131000 1774736 NOTE: The values shown here are values for an ideal RTD channel. The actual calibration setpoints may be different.

RTD CONVERSION VOLTS TO OHMS (LIST RTD)**RTD 1 (RTD 1)**

VARIABLE	RTD 1 <R0> <A>
VALID VALUES	any real number
DEFAULT VALUE	R0 - 100.00000 A - 3.908E-03 B - (-)5.775E-07
DATA TYPE	float
DESCRIPTION	The conversion factors for RTD 1 to convert ohms to millivolts for temperature conversion. The actual values are provided by the manufacturer. The values for A and B must be entered as exponents.

RTD 2 (RTD 2)

VARIABLE	RTD 2 <R0> <A>
VALID VALUES	any real number
DEFAULT VALUE	R0 - 100.00000 A - 3.908E-03 B - (-)5.775E-07
DATA TYPE	float
DESCRIPTION	The conversion factors for RTD 2 to convert ohms to millivolts for temperature conversion. The actual values are provided by the manufacturer. The values for A and B must be entered as exponents.

RTD 3 (RTD 3)

VARIABLE	RTD 3 <R0> <A> (32 and 64 channel version only)
VALID VALUES	any real number
DEFAULT VALUE	R0 - 100.00000 A - 3.908E-03 B - (-)5.775E-07
DATA TYPE	float
DESCRIPTION	The conversion factors for RTD 3 to convert ohms to millivolts for temperature conversion. The actual values are provided by the manufacturer. The values for A and B must be entered as exponents.

RTD 4 (RTD 4)

VARIABLE	RTD 4 <R0> <A> (32 and 64 channel version only)
VALID VALUES	any real number
DEFAULT VALUE	R0 - 100.00000 A - 3.908E-03 B - (-)5.775E-07
DATA TYPE	float
DESCRIPTION	The conversion factors for RTD 4 to convert ohms to millivolts for temperature conversion. The actual values are provided by the manufacturer. The values for A and B must be entered as exponents.

RTD 5 (RTD 5)

VARIABLE	RTD 5 <R0> <A> (64 channel version only)
VALID VALUES	any real number
DEFAULT VALUE	R0 - 100.00000 A - 3.908E-03 B - (-)5.775E-07
DATA TYPE	float
DESCRIPTION	The conversion factors for RTD 5 to convert ohms to millivolts for temperature conversion. The actual values are provided by the manufacturer. The values for A and B must be entered as exponents.

RTD 6 (RTD 6)

VARIABLE	RTD 6 <R0> <A> (64 channel version only)
VALID VALUES	any real number
DEFAULT VALUE	R0 - 100.00000 A - 3.908E-03 B - (-)5.775E-07
DATA TYPE	float
DESCRIPTION	The conversion factors for RTD 6 to convert ohms to millivolts for temperature conversion. The actual values are provided by the manufacturer. The values for A and B must be entered as exponents.

RTD 7 (RTD 7)

VARIABLE	RTD 7 <R0> <A> (64 channel version only)
VALID VALUES	any real number
DEFAULT VALUE	R0 - 100.00000 A - 3.908E-03 B - (-)5.775E-07
DATA TYPE	float
DESCRIPTION	The conversion factors for RTD 7 to convert ohms to millivolts for temperature conversion. The actual values are provided by the manufacturer. The values for A and B must be entered as exponents.

RTD 8 (RTD 8)

VARIABLE	RTD 8 <R0> <A> (64 channel version only)
VALID VALUES	any real number
DEFAULT VALUE	R0 - 100.00000 A - 3.908E-03 B - (-)5.775E-07
DATA TYPE	float
DESCRIPTION	The conversion factors for RTD 8 to convert ohms to millivolts for temperature conversion. The actual values are provided by the manufacturer. The values for A and B must be entered as exponents.

CHANNEL GAIN CORRECTION VARIABLES (LIST G)

GAINS (GAIN)

VARIABLE	GAIN <channel> <gain value>
VALID VALUES	any real number
DEFAULT VALUE	1
DATA TYPE	float
DESCRIPTION	Sets the GAIN correction for a given channel using the formula: Adjusted Counts = (GAIN * counts) + OFFSET.

CHANNEL OFFSET CORRECTION VARIABLES (LIST O)

OFFSETS (OFFSET)

VARIABLE	OFFSET <channel> <gain value>
VALID VALUES	any real number
DEFAULT VALUE	1
DATA TYPE	float
DESCRIPTION	Sets the OFFSET correction for a given channel using the formula: Adjusted Counts = (GAIN * counts) + OFFSET.

RTD CALIBRATION VARIABLES (LIST U)

ARPC (ARPC)

VARIABLE	ARPC <board> <value>
VALID VALUES	board - 1, 2, 3 or 4
DEFAULT VALUE	0.0000
DATA TYPE	floating point
DESCRIPTION	This value is the offset value that will be added to the RTD volts value before the Calendar Van-Dusen conversion. This value is calculated from the ARPC command. The software will update the ARPC variable setting after an ARPC command is executed. A LIST U command will only display the number of boards installed. That is: a 16 channel module will only display ARPC 1. A 32 channel module will display ARPC 1 and ARPC 2. A 64 channel module will display ARPC 1, ARPC 2, ARPC 3 and ARPC 4. The software will only allow entry of values for the number of boards installed.

ARPCON (ARPCON)

VARIABLE	ARPCON <value>
VALID VALUES	0 or 1
DEFAULT VALUE	0
DATA TYPE	integer
DESCRIPTION	When set to one, this variable will enable the ARPC correction.

MAXIMUM RTD DELTA (MAXDELTA)

VARIABLE	MAXDELTA <value>
VALID VALUES	any real number
DEFAULT VALUE	.25
DATA TYPE	Integer
DESCRIPTION	This is the maximum allowable difference between the readings of RDT1 and RTD2 in degrees C. If MAXDELTA exceeds this setpoint, bit 12 is set to 1 in the general status element of the data packet (appears immediately after the RTD reading.)

NUMBER OF RTD SETPOINTS (RNUMPTS)

VARIABLE	RNUMPTS <points>
VALID VALUES	1 to 8
DEFAULT VALUE	8
DATA TYPE	integer
DESCRIPTION	Determines the number of setpoints in the RTD correction list.

NUMBER OF RTD COEFFICIENTS (RNUMCOEF)

VARIABLE	RNUMCOEF <coef>
VALID VALUES	1 to 7
DEFAULT VALUE	5
DATA TYPE	integer
DESCRIPTION	Determines the number of calibration coefficients in the RTD correction list. 1 - Offset only 2 - $y = mx + b$ 3 - $y = ax^2 + bx + c$ 4 - $y = ax^3 + bx^2 + cx + d$ 5 - $y = ax^4 + bx^3 + cx^2 + dx + e$ 6 - $y = ax^5 + bx^4 + cx^3 + dx^2 + ex + f$ 7 - $y = ax^6 + bx^5 + cx^4 + dx^3 + ex^2 + fx + g$

DTS PACKET DEFINITIONS

When requested, the DTS sends an application packet to the client. Each packet sent to the client starts with a Packet Type Word. This word defines the packet type.

PACKET TYPE TABLE

PACKET NAME	PACKET ID	BYTES	NOTES
16 Channel Data	0Hex	168	
Host Control	1Hex	168	Command Packet
32 Channel Data	2Hex	304	
64 Channel Data	3Hex	576	
16 Channel Data w/ PTP Enabled	4Hex	168	
32 Channel Data w/ PTP Enabled	6Hex	304	
64 Channel Data w/ PTP Enabled	7Hex	576	
ASCII	20Hex	Variable	Text Packet may be formatted or un-formatted. The format is determined by the setting of the FORMAT Configuration Variable. NOTE: When the first integer of the packet is 20Hex or greater, the packet is assumed to be in ASCII FORMAT.

HOST CONTROL PACKETS

COMMAND PACKET

FUNCTION DESCRIPTION	BYTES	DESCRIPTION
Packet Type	4	1Hex
Host ASCII Command Data (Refer to the Command Section of this manual for more information)	164	ASCII string received by DTS as the Host command. Each line must be terminated with a CR, LF, CR-LF or LF-CR.

DTS TO HOST***BINARY DATA PACKETS (DTS4050/16 CHANNEL MODULE)***

FUNCTION	BYTES	DATA TYPE	DESCRIPTION
Packet Type	4	Integer	0Hex
General Status	4	Integer	Refer to Table 1 in this section
Frame Number	4	Integer	The current frame number if in the scan mode
Temperature 1 to 16	64	Float	Channel temperatures in units set by bits 4 - 6 of the General Status Byte.
RTD1 Temperature	4	Float	Temperature in units defined by the setting of the variable: UNITS. See Table 3
RTD2 Temperature	4	Float	Temperature in units defined by the setting of the variable: UNITS. See Table 3
Time Stamp	4	Integer	Time Stamp in units set by bit 8 of the General Status Byte.
Channel Status 1 to 16	64	Integer	Refer to Table 2 in this section
PTP Time (Seconds)	4	Integer	Current PTP time stamp in seconds
PTP Time (Nanoseconds)	4	Integer	Current PTP time stamp in nanoseconds
PTP Last Update (ms)	4	Integer	Time Elapsed Since Last PTP Update in ms
Spares	4	Integer	Spares

BINARY DATA PACKETS (DTS4050/32 CHANNEL MODULE)

FUNCTION	BYTES	DATA TYPE	DESCRIPTION
Packet Type	4	Integer	2Hex
General Status	4	Integer	Refer to Table 1 in this section
Frame Number	4	Integer	The current frame number if in the scan mode
Temperature 1 to 32	128	Float	Channel temperatures in units set by bits 4 - 6 of the General Status Byte.
RTD1 Temperature	4	Float	Temperature in units defined by the setting of the variable: UNITS. See Table 3
RTD2 Temperature	4	Float	Temperature in units defined by the setting of the variable: UNITS. See Table 3
RTD3 Temperature	4	Float	Temperature in units defined by the setting of the variable: UNITS. See Table 3.
RTD4 Temperature	4	Float	Temperature in units defined by the setting of the variable: UNITS. See Table 3
Time Stamp	4	Integer	Time Stamp in units set by bit 8 of the General Status Byte.
Channel Status 1 to 32	128	Integer	Refer to Table 2 in this section
PTP Time (Seconds)	4	Integer	Current PTP time stamp in seconds
PTP Time (Nanoseconds)	4	Integer	Current PTP time stamp in nanoseconds
PTP Last Update (ms)	4	Integer	Time Elapsed Since Last PTP Update in ms
Spares	4	Integer	Spares

BINARY DATA PACKETS (DTS4050/64 CHANNEL MODULE)

FUNCTION	BYTES	DATA TYPE	DESCRIPTION
Packet Type	4	Integer	3Hex
General Status	4	Integer	Refer to Table 1 in this section
Frame Number	4	Integer	The current frame number if in the scan mode
Temperature 1 to 64	256	Float	Channel temperatures in units set by bits 4 - 6 of the General Status Byte.
RTD1 Temperature	4	Float	Temperature in units defined by the setting of the variable: UNITS. See Table 3
RTD2 Temperature	4	Float	Temperature in units defined by the setting of the variable: UNITS. See Table 3
RTD3 Temperature	4	Float	Temperature in units defined by the setting of the variable: UNITS. See Table 3
RTD4 Temperature	4	Float	Temperature in units defined by the setting of the variable: UNITS. See Table 3
RTD5 Temperature	4	Float	Temperature in units defined by the setting of the variable: UNITS. See Table 3
RTD6 Temperature	4	Float	Temperature in units defined by the setting of the variable: UNITS. See Table 3
RTD7 Temperature	4	Float	Temperature in units defined by the setting of the variable: UNITS. See Table 3
RTD8 Temperature	4	Float	Temperature in units defined by the setting of the variable: UNITS. See Table 3
Time Stamp	4	Integer	Time Stamp in units set by bit 8 of the General Status Byte.
Channel Status 1 to 64	256	Integer	Refer to Table 2 in this section
PTP Time (Seconds)	4	Integer	Current PTP time stamp in seconds
PTP Time (Nanoseconds)	4	Integer	Current PTP time stamp in nanoseconds
PTP Last Update (ms)	4	Integer	Time Elapsed Since Last PTP Update in ms
Spares	4	Integer	Spares

GENERAL STATUS BYTE

Bits 0 - 3 Not used
 Bits 4 - 6 Temperature Units
 Bit 7 Not Used
 Bit 8 Time Stamp
 Bits 9 - 11 Not Used
 Bits 12 - 15 RTD Delta Errors

GENERAL STATUS BYTE

Bit	15	14	13	12	11	10	9	8	7	6	5	4	3	2	1	0
0 - Raw A/D Counts (Uncorrected)	X	X	X	X	X	X	X	X	X	0	0	0	X	X	X	X
V - Raw Voltage (Uncorrected)	X	X	X	X	X	X	X	X	X	0	0	1	X	X	X	X
A - Corrected Voltage	X	X	X	X	X	X	X	X	X	0	1	0	X	X	X	X
C - Degrees C	X	X	X	X	X	X	X	X	X	0	1	1	X	X	X	X
F - Degrees F	X	X	X	X	X	X	X	X	X	1	0	0	X	X	X	X
K - Degrees K	X	X	X	X	X	X	X	X	X	1	0	1	X	X	X	X
R - Degrees R	X	X	X	X	X	X	X	X	X	1	1	0	X	X	X	X
Number of Temp Scales (Not Used)	X	X	X	X	X	X	X	X	X	1	1	1	X	X	X	X
Time Stamp in microseconds	X	X	X	X	X	X	X	X	0	X	X	X	X	X	X	X
Time Stamp in milliseconds	X	X	X	X	X	X	X	X	1	X	X	X	X	X	X	X
No Errors	0	0	0	0	X	X	X	X	X	X	X	X	X	X	X	X
UTR1 Delta Error (16, 32, 64)	0	0	0	1	X	X	X	X	X	X	X	X	X	X	X	X
UTR2 Delta Error (32, 64)	0	0	1	0	X	X	X	X	X	X	X	X	X	X	X	X
UTR3 Delta Error (64)	0	1	0	0	X	X	X	X	X	X	X	X	X	X	X	X
UTR4 Delta Error (64)	1	0	0	0	X	X	X	X	X	X	X	X	X	X	X	X

CHANNEL STATUS BYTE

Bits 0 - 4 Thermocouple Type
 Bits 5 - 11 Not Used
 Bits 12 - 15 Error Codes

CHANNEL STATUS BYTE

Bit	15	14	13	12	11	10	9	8	7	6	5	4	3	2	1	0
Type J	X	X	X	X	X	X	X	X	X	0	0	0	0	0	0	0
Type E	X	X	X	X	X	X	X	X	X	0	0	0	0	0	0	1
Type K	X	X	X	X	X	X	X	X	X	0	0	0	0	0	1	0
Type N	X	X	X	X	X	X	X	X	X	0	0	0	0	0	1	1
Type R	X	X	X	X	X	X	X	X	X	0	0	0	0	1	0	0
Type S	X	X	X	X	X	X	X	X	X	0	0	0	0	1	0	1
Type T	X	X	X	X	X	X	X	X	X	0	0	0	0	1	1	0
Type B	X	X	X	X	X	X	X	X	X	0	0	0	0	1	1	1
A/D Disabled	0	0	0	1	X	X	X	X	X	X	X	X	X	X	X	X
Open T/C	0	0	1	0	X	X	X	X	X	X	X	X	X	X	X	X
High Range Error	0	0	1	1	X	X	X	X	X	X	X	X	X	X	X	X
Low Range Error	0	1	0	0	X	X	X	X	X	X	X	X	X	X	X	X
High Limit Exceeded	0	1	0	1	X	X	X	X	X	X	X	X	X	X	X	X
Low Limit Exceeded	0	1	1	0	X	X	X	X	X	X	X	X	X	X	X	X

RTD UNITS

UNITS	RTD Units
A	millivolts
C	Degrees C
F	Degrees C
K	Degrees C
M	Degrees C
R	Degrees C
V	millivolts
0	A/D counts

ASCII DATA PACKET

This packet will be transmitted when the host issues one of the following commands:

- 1) SCAN with BIN set to 0
- 2) LIST n
- 3) ERROR
- 4) STATUS

ASCII data can be output in three different basic forms;

- 1) Unformatted
- 2) Unformatted with PTP data
- 3) Formatted

FUNCTION DESCRIPTION	BYTES	DATA TYPE	VALUE
ASCII Data (The first two bytes must NOT be 1Hex through 1FHex). Refer to the Command Section of this manual for the proper Command return formats.	1 to 1492 (Variable length)	String	Unique to Packet. Each line is terminated with a CR, LF, CR-LF, or LF-CR.

UNFORMATTED WITHOUT PTP DATA

Unformatted data is output in a streaming, multi-column format. Each frame of data has a header with the frame number, RTD readings and temperature units listed. The data columns are: Channel, Reading, Status Code.

Example:

```

Frame # 3
Rtd1  33.71 C
Rtd2  33.72 C 0
Rtd3  25.00 C
Rtd4  25.00 C 1
Units C
01  21.89 0
02 -9999.99 4000
03  9999.99 3000
04 -9999.99 4000
05  9999.99 3000
06  9999.99 3000
07  9999.99 5000
08  9999.99 3000
09  9999.99 3000
10  9999.99 3000
11 -9999.99 4000
12 -9999.99 4000
13  9999.99 3000
14 -9999.99 4000
15  9999.99 3000
16  9999.99 3000
17  28.62 0
18  29.15 0
19  29.09 0
20  29.51 0
21  29.34 0
22  29.63 0
23  29.87 0
24  30.74 0
25  30.63 0
26  31.02 0
27  30.71 0
28  31.57 0
29  31.12 0
30  31.30 0
31  31.59 0
32  32.15 0

```

UNFORMATTED WITH PTP DATA

Unformatted with PTP data is output in a streaming, multi-column format. Each frame of data has a header with the frame number, PTP time, RTD readings and temperature units listed. The data columns are: Channel, Reading, Status Code. This output configuration is exactly the same as unformatted without PTP data with the only difference being the addition of the PTP time in the second line of the header.

Example:

```

Frame # 2
PTP Time 2013/04/24 15:09:26.585355
Rtd1  33.69 C
Rtd2  33.70 C 1
Rtd3  25.00 C
Rtd4  25.00 C 1
Units C
01  22.06 0
02 -9999.99 4000
03  9999.99 3000
04 -9999.99 4000
05  9999.99 3000
06  9999.99 3000
07  9999.99 3000
08  9999.99 3000
09  9999.99 3000
10  9999.99 3000
11 -9999.99 4000
12 -9999.99 4000
13  9999.99 3000
14 -9999.99 4000
15  9999.99 3000
16  9999.99 3000
17  28.62 0
18  29.15 0
19  29.09 0
20  29.51 0
21  29.34 0
22  29.63 0
23  29.87 0
24  30.74 0
25  30.63 0
26  31.02 0
27  30.71 0
28  31.57 0
29  31.12 0
30  31.30 0
31  31.59 0
32  32.15 0

```

FORMATTED

If data formatting is enabled (variable SET FORMAT 1), the data is displayed in a block-style format. This configuration is preferred for manual viewing but is not desirable for data collection. PTP data is not available in formatted data.

Example:

```

Frame=0000000
Rtd1=  19.70 C Rtd2=  19.71 C Rtd3=  19.72 C
Rtd4=  19.71 C Units=C

01= -9999.99 02= -9999.99 03= -9999.99 04=
-9999.99 05=  9999.99 06= -9999.99
07=  9999.99 08= -9999.99 09= -9999.99 10=
-9999.99 11= -9999.99 12= -9999.99
13= -9999.99 14= -9999.99 15=  9999.99 16=
-9999.99 17= -9999.99 18= -9999.99
19= -9999.99 20= -9999.99 21= -9999.99 22=
9999.99 23= -9999.99 24= -9999.99
25=  9999.99 26= -9999.99 27= -9999.99 28=
9999.99 29= -9999.99 30= -9999.99
31= -9999.99 32=  9999.99

```

NETWORK PROTOCOLS SUPPORTED

Physical Layer : 10Base-T IEEE 802.3
Link Layer: INTERNET Protocol (IP)
Transport Layer: Transmission Control Protocol (TCP)
User Datagram Protocol (UDP)

SECTION 6: MAINTENANCE

CALIBRATION

All DTS4050 modules are calibrated before they are shipped. The calibration performed at Scanivalve is traceable to NIST. Scanivalve recommends subsequent calibrations at 6 month intervals in order to maintain accuracy. Calibrations may be performed at the Scanivalve factory or by a customer in the field. Customers who wish to perform their own calibrations can use Scanivalve's free calibration software, TempCal. TempCal can be downloaded at no cost from the Scanivalve website at www.scanivalve.com.

The TempCal software calibrates the voltage A/Ds in the DTS4050 module. It can be operated in either automatic or manual mode depending on the voltage standard being used. In order to calibrate a DTS using TempCal, a calibration harness is required. The calibration harness can be ordered from Scanivalve using the following part numbers:

- 21079-1 (for 16 channel DTS modules)
- 21079-2 (for 32 channel DTS modules)
- 21079-3 (for 64 channel DTS modules)

In addition to the calibration harness, a host computer running Windows XP or Windows 7 and a DC voltage standard with a range of -10mV to +131mV and an accuracy of $\pm 1.5\mu\text{V}$ or better is required. The procedure for performing a voltage calibration on a DTS using TempCal can be found in the TempCal software manual.

TempCal does not perform a recalibration of the RTDs. Calibration of the RTDs should be completed on a five year interval. Consult Scanivalve directly for a copy of the "full" calibration procedure including calibrating the RTDs. In order to perform a complete calibration, the following additional equipment is required:

- Digital Volt/Ohmmeter - $\pm 10\mu\text{V}$ accuracy from 95 to 105mVdc
- 100 Ω standard resistor - accurate within $\pm 0.001\%$
- Ice point reference
- Thermocouple simulator

A/D CALIBRATION (ADCAL)

The DTS4050 includes an internal A/D self-calibration function called "ADCAL." This is automatically performed at powerup and whenever the PERIOD variable is changed however it is recommended that the ADCAL be performed periodically in certain situations. Scanivalve recommends that an ADCAL be performed after the module has warmed

up and reached a stable temperature. An ADCAL should also be performed if the DTS is subjected to an ambient temperature change of more than 5°C. Finally, if the DTS has been running continuously for more than a 1 week period, an ADCAL should be performed. For more information on the ADCAL, see "A/D Calibration" on page 27.

INTERNET EXPLORER SETUP FOR FTP

The firmware and coefficient procedures that follow may not function correctly if Windows Internet Explorer is not set up correctly. A user should verify these settings before attempting these procedures.

1. Open Internet Explorer.
2. Click on Tools
3. Select Internet Options from the drop down menu. The Internet Options window will open.

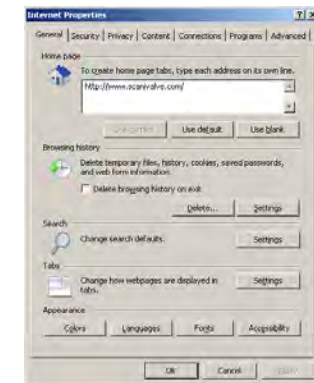

4. Click on the Advanced Tab.
5. Scroll down to the Heading marked "Browsing"
6. Make sure that the line "Enable FTP Folder View (Outside of Internet Explorer)" is checked. If this is not enabled, Internet Explorer will block FTP file transfers.



7. Click OK to accept the settings.

[This page intentionally left blank]

DTS4050 FIRMWARE INSTALLATION (WINDOWS XP & 7)

NOTE: Some firewalls may block file transfers. We recommend that firewalls be shut down for the procedures in this section.

1. Connect a host computer to the Ethernet port.
 2. Install the disk with the New or updated firmware (Dts4000.Hex) into a drive.
 3. Open My Computer
 4. In the Address Bar, type: ftp://<IPAddress><Enter>
- Where: <IPAddress> is the IP Address of the DTS4050.
5. The host computer should connect, If the connection is successful, the contents of the DTS4050 Flash chip will be displayed in a folder format.

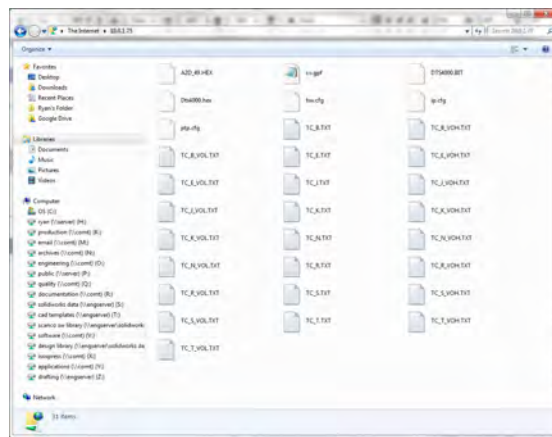

6. Highlight the existing Dts4000.Hex file. Right Click on it and select Delete. A window will open to confirm the delete. Click Yes to delete the file.

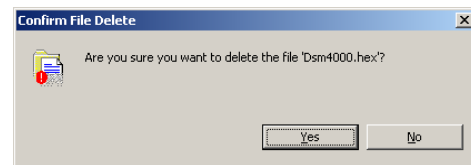

7. Open Windows Explorer in another window. Find the directory where the new Dts4000.Hex file is stored. Highlight the file and
 - Click: Edit
 - Click: Copy
8. Select the DTS4050 window and,
 - Click: Edit
 - Click: Paste

The file will be copied to the DTS4050. A progress window will provide progress information.

9. When the copy function is complete, the DTS4050 window will show the new file. The time and date will show the Time and Date of the transfer. This is the only time this date will be shown. All files on the DTS4050 will show the same date and time after a reboot or power cycle: August 1, 2008 00:00
10. Cycle the AC power or execute a Reboot command to complete the process.

OPERATING IN BOOTLOADER MODE

If the DTS4050 will not boot, or appears to have lost communications with a Host, the system may be operated in the Bootloader Mode. In this mode of operation, the application will not start. A list of commands that may be used in the bootloader mode can be found in "DSP Boot Loader" on page 18. All commands may be entered by the Ethernet or Configuration ports.

This mode may be set by switching Dip Switch 1 to the on position.



CAUTION! ESD PROTECTION REQUIRED. The proper use of grounded work surfaces and personal wrist straps are required when coming into contact with exposed circuits to prevent static discharge from damaging sensitive electronic components.

1. Switch the input power off, and remove the DTS4050 top insulating cover. In order to access the Dip Switches, the connector end cover must be removed. Removed the nine phillips screws shown and carefully pull the end cover off of the unit.

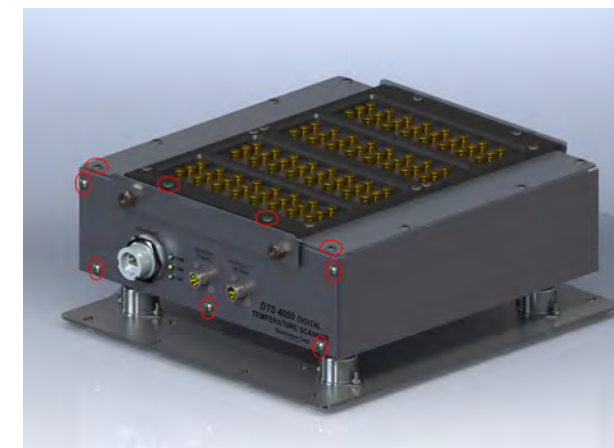

2. The dip switches are located on the front edge of the processor board. For reference purposes, OFF is towards the bottom of the DTS4050, and on is towards the top of the DTS4050 (towards the circuit board). Slide DIP switch #1 up to turn it on.



3. Re-apply power to the DTS4050. The application will not run, but the bootloader commands can be used to troubleshoot system problems.
4. The most common reason to enter the bootloader is to check or change the IP address of the unit. Once the unit has booted up in the bootloader, send the command "LIST IP" The variable IPADD sets the device IP address. If desired, it can be modified and then saved with the SAVEIP command. Once the save has completed, cycling the power on the unit will implement the new IP address.
5. When troubleshooting is complete, remove power and reset switch #1 to the off position (towards the bottom of the unit). Reinstall the top cover and re-apply power.

REFORMATTING THE DTS4050

Should the file system on the DTS4050 become corrupted, the unit would have to be reformatted. This procedure will delete all data on the DTS4050. Before performing this operation, ensure that all files can be recovered. This can be done by copying the files off of the DTS before reformatting it, or by retrieving the files from the Resource Disk supplied with the unit.

1. Begin by powering the DTS unit down and configuring it to operate in bootloader mode (see "Operating in Bootloader Mode" on page 85).
2. Power the DTS4050 up and establish an Ethernet connection as normal. Because the DIP switches have been reconfigured, you will boot in the bootloader instead of the application. Verify the connection is good by sending the VER command. The DTS4050 should respond with the version of the bootloader (not the application!).
3. To format the SD card, send the command:

FDISK

Followed by:

FDISKCONFIRM

It will take about 5-10 seconds for the disk to completely format.

4. When the DTS4050 was formatted, all information including the IP Address was lost. To reset a new IP address, send the command:

SET IPADD xxx.xxx.xxx.xxx

*(where xxx.xxx.xxx is the new IP address)

Verify the IP address is set properly by sending the LIST S command and checking the setting of the IPADD variable. If it is correct, save the new IP address by sending the command:

SAVEIP

Followed by:

SAVEIPCONFIRM

If the IP Address is not set at this point and the DTS4050 is powered down, the default IP address will be used. At this point, the flash memory has been formatted and the DTS4050's IP address has been re-established.

5. Power the DTS4050 down. Remove the processor

board assembly and reconfigured the DIP switches for normal operation.

6. Power the DTS4050 back up. Establish an Ethernet connection to is using the IP address established in step 4 as normal. At this point, the DTS4050 will be operating completely on factory defaults with no calibration coefficients loaded. FTP to the unit using your preferred method and restore the application file (DTS4000.hex), factory coefficients and the CV.GPF (basic configuration file). All of the configuration files and the application file can be found on the DTS4050 Resource Disk supplied with the DTS4050. If there is not an archived copy of this file, each of the configuration variables can be reconfigured manually through the SET commands and then saved with the SAVE command.

APPENDIX**APPENDIX A: THERMOCOUPLE****INFORMATION****THERMOCOUPLE BASICS**

When two dissimilar metals are joined together to form a closed loop, and if one junction is held at a different temperature from the other, an Electromotive Force (EMF) is generated. The amount of EMF generated is predictable based on the materials used and the temperature of the junction.

The EMF is generated by the wires, not the junction. A temperature gradient must exist before the EMF can be generated.

Three laws have been established that govern thermoelectric circuits.

Law of Homogeneous Materials:

A thermoelectric current cannot be sustained in a circuit of a single homogeneous material, however it varies in cross section, by the application of heat alone. Simply stated, two different materials are required for any thermocouple circuit. If current can be detected in a homogeneous wire when it is heated, this is evidence that the wire is in-homogeneous.

Law of Intermediate Materials:

The algebraic sum of the thermoelectromotive forces in a circuit composed of any number of dissimilar materials is zero if all of the circuit is at a uniform temperature. This law states that a third homogeneous material can be added to a circuit with no effect on the net EMF of the circuit as long as temperature of the junctions remain the same.

Law of Successive or Intermediate Temperature:

If two dissimilar homogeneous materials produce a thermal EMF of E_1 when the junctions are at temperature T_1 and T_2 , and a thermal EMF of E_2 when the junctions are at T_2 and T_3 , the EMF generated when the junctions are at T_1 and T_3 will be $E_1 + E_2$. This law states that a thermocouple calibrated for one reference temperature can be used with any other reference temperature with a correction. Also, extension wires having the same characteristics as those of the thermocouple wires can be introduced to the circuit without affecting the circuit.

Thermocouple Circuits:

A basic thermocouple circuit consists of two dissimilar homogenous materials extending from the measuring junction to the reference junction.

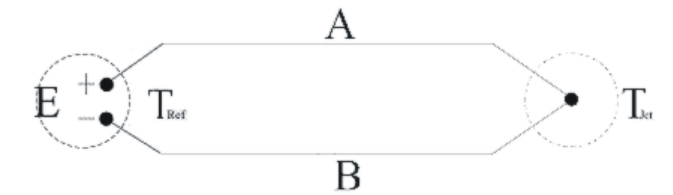

When more than one thermocouple is to be measured, each thermocouple should be two continuous wires between the measuring and reference junctions. This is the most common circuit for thermoelectric testing.

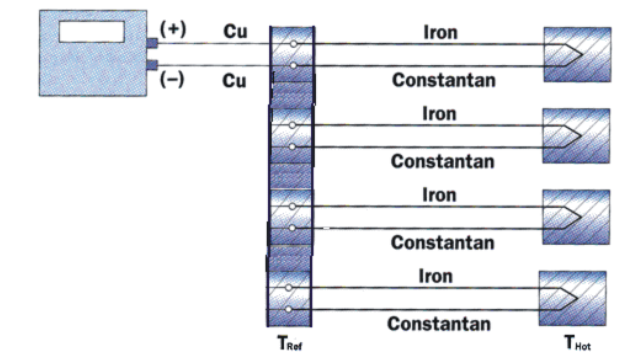
**Thermocouple Accuracy:**

Thermocouple accuracy can be defined as relative and absolute accuracy.

Relative Accuracy

This is the ability of the system to repeat a given measurement. This depends upon the quality of the sensors, the measuring system used and how the system is installed.

Absolute Accuracy

This is the ability of the system to determine a standard accepted value. This can be achieved by calibration relative accepted and recognized standards.

Thermocouple Calibration:

Calibration will not change the characteristics of a thermocouple. It does validate the system and ensure proper readings by allowing corrections to be entered for each thermocouple in the system. Calibrations should conform to ISO 10012-1:1992.

SOURCES OF ERROR IN THERMOCOUPLE MEASUREMENTS

Measuring Junction

The thermocouple junction at the temperature measuring point is the measuring junction. Errors at this point depend upon the age of the junction, the method of joining and materials used to form the junction. Generally, errors from the measuring junction are small.

Extension Wires

Extension wires are any elements inserted between the measuring junction and the reference junction. Extension wires should have the same characteristics as the thermocouple wire. Extension wires introduce four junctions to each circuit. This can cause errors as large as $\pm 2^\circ\text{C}$. The errors can be minimized by calibrating the system with the extension wires in place. If possible, extension wires should not be used.

Reference Junctions

The thermocouple junction maintained at a known temperature is the reference junction. Reference junctions can introduce errors as large as $\pm 0.6^\circ\text{C}$.

Copper Connecting Wires

These wires are used to connect the reference junction to the measuring device. The errors caused by these wires are very small.

Thermocouple Switches

When used, these devices can induce errors as large as $\pm 1^\circ\text{C}$. Switching should occur in the copper wires between the reference junction and the measuring device.

NOISE IN THERMOCOUPLE CIRCUITS

The external effects that can cause errors in thermocouple circuits include: electrical and magnetic fields, cross-talk, and common mode voltage.

Electric fields radiated from voltage sources are capacitively coupled to thermocouple extension wires. This imposes an AC voltage on the thermoelectric EMF. This can be minimized by shielding the thermocouple extension wire and grounding the shield.

Magnetic fields produce noise current in the thermocouple extension wire. This can be minimized by twisting the thermocouple extension wire pairs.

In a multipair thermocouple extension wire, adjacent pairs can pick up noise from a pulsating signal. This can be minimized by shielding the individual pairs.

Common mode noise will be generated if a grounded

thermocouple is connected to a grounded instrument. This can be minimized by grounding the thermocouple and shield as close as possible to the measuring point.

THERMOCOUPLE DESIGN

The thermocouple used in an application should be selected specifically for the application.

Size: The temperature sensed will be the average temperature across the length of the sensor.

Shape: The shape must conform to the shape of the surface if the thermocouple is measuring surface temperatures.

Response: The response time of a thermocouple is mass dependent. Therefore the size of the thermocouple must be small in relation to the object being measured. The response time should be approximately 5 times shorter than the fastest rate of temperature change to be monitored.

Heat Conduction: Thermocouple extension wires can conduct heat into or out of the thermocouple. The wire must be insulated from the environment if this can occur.

Sensor Position: The thermocouple measures the temperature of the object it is touching or the environment in which it is installed. Therefore the thermocouple must be positioned very carefully to insure that the temperature is being sensed at the correct point.

THERMOCOUPLE TYPES AND DESCRIPTIONS

The DTS family of Temperature Scanners will accept inputs from Type E, J, K, N, R, S, and T Thermocouples. The accuracy of the measurement will depend upon the type of thermocouple and the quality of the extension wire used for the measurement.

Type B

Positive leg 70% platinum, 30% rhodium
 Negative leg 94% platinum, 6% rhodium
 Range 0 to 1800C
 Usable range 400 to 1704C
 Notes Easily contaminated and damaged by reducing atmospheres. This thermocouple should be protected with a gas tight ceramic tube, a secondary tube of porcelain and a silicon carbide or metal outer tube.

Type E - Chromel Constantan

Positive leg 90% nickel, 10% chromium
 Negative leg 43% nickel, 57% copper
 Range -270 to 1000C
 Usable range 0 to 900C
 Notes Highest EMF output per degree of all recognized thermocouples. Has similar drift between 316 and 593C as a Type K thermocouple

Type J - Iron Constantan

Positive leg 100% iron
 Negative leg 43% nickel, 57% copper
 Range -210 to 1200C
 Usable range 0 to 816C
 Notes Not susceptible to aging from 371 to 538C. Very stable, should be used with a 96% pure MgO insulation and stainless steel sheath to prevent corrosion of the iron lead. Most commonly used thermocouple.

Type K - Chromel Alumel

Positive leg 90% nickel, 10% chromium
 Negative leg 95% nickel, 2% aluminum, 2% manganese, 1% silicon
 Range -270 to 1372C
 Usable range -36 to 1260C
 Notes Not recommended from 316 to 593C because of aging that can cause drift rates of 2C in a few hours. Best used when corrosion may be a problem.

Type N

Positive leg 14% chromium, 1.4% silicon, 84.6% nickel
 Negative leg 95.6% nickel, 4.4% silicon
 Range -270 to 1372C
 Usable range 0 to 1260C
 Notes Less aging from 316 to 593C than a Type K thermocouple.

Type R

Positive leg 87% platinum, 13% rhodium
 Negative leg 100% platinum
 Range -50 to 1767C
 Usable range 0 to 1482C
 Notes Has a higher output than Type S thermocouples. Easily contaminated. This thermocouple should be protected by compacted mineral insulation and a metal outer sheath.

Type S

Positive leg 90% platinum, 10% rhodium
 Negative leg 100% platinum
 Range -50 to 1767C
 Usable range 0 to 1482C
 Notes Easily contaminated. This thermocouple should be protected with a gas tight ceramic tube, a secondary tube of porcelain and a silicon carbide or metal outer tube.

Type T - Copper Constantan

Positive leg Pure copper
 Negative leg 43% nickel, 57% copper
 Range -270 to 400C
 Usable range -262 to 350C
 Notes Good for low temperature and cryogenic applications

INTERNATIONAL THERMOCOUPLE AND EXTENSION WIRE COLOR CODES

Country	USA	USA	United Kingdom	United Kingdom	Germany	Japan	Fance
Standard	ANSIMC96.1 T/C	ANSI MC96.1 Extension	BS 1843	BS 4937	DIN 43714	JIS C1610-1981	NFE C42-323
B Overall B Positive B Negative	-	Gray Gray Red	-	-	Gray Red Gray	Gray Red Gray	-
E Overall E Positive E Negative	Brown Purple Red	Purple Purple Red	Brown Brown Blue	Brown Brown Blue	Black Red Black	Purple Red White	-
J Overall J Positive J Negative	Brown White Red	Black White Red	Black Yellow Blue	Black Black White	Blue Red Blue	Yellow Red White	Black Yellow Black
K Overall K Positive K Negative	Brown Yellow Red	Yellow Yellow Red	Red Brown Blue	Green Green White	Green Red Green	Blue REd White	Yellow Yellow Purple
N Overall N Positive N Negative	Brown Orange Red	Orange Orange Red	-	-	-	-	-
R Overall R Positive R Negative	-	Green Black Red	Green White Blue	Orange Orange White	White Red White	Black Red White	Green Yellow Green
S Overall S Positive S Negative	-	Breen Black Red	Green White Blue	Orange Orange White	White Red White	Black Red White	Green Yellow Green
T Overall T Positive T Negative	Brown Blue Red	Blue Blue Red	Blue White Blue	Brown Brown White	Brown Red Brown	Brown Red White	Blue Yellow Blue

APPENDIX B - SOFTWARE CHANGE LIST

Version 1.00 - Initial software release. (08/26/2013)

Version 1.01 - Updated to add MINRATE variable (4/21/14)

Version 1.02 - Changed the rate of the RTD A/D to 3x the T/C A/D rate. (6/11/14)

[This page intentionally left blank]

Scanivalve

1722 N. MADSON ST.
LIBERTY LAKE, WA 99019

PHONE: 1-800-935-5151
1-509-891-9970
FAX: 1-509-891-9481

SCANCO@SCANIVALVE.COM
WWW.SCANIVALVE.COM