

NOTES:

1. MATERIALS: CENTER BLOCK IS ALUMINUM AND TUBULATIONS ARE STAINLESS STEEL. FITTINGS ARE ASSEMBLED USING EPOXY.

2. REF: PRODUCT PART NUMBERS:

- 5958-X FOR .031 TUBULATIONS
- 5073-X FOR .040 TUBULATIONS
- 5083-X FOR .063 TUBULATIONS
- 5088-x FOR .093 TUBULATIONS
- 5093-X FOR .125 TUBULATIONS

REVISIONS				
ZONE	REV.	DESCRIPTION	DATE	APPROVED

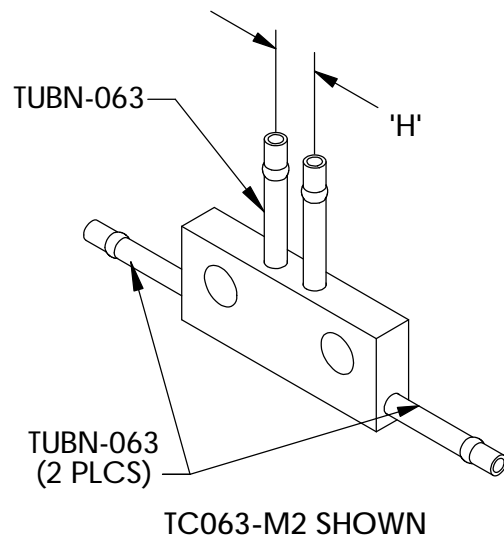
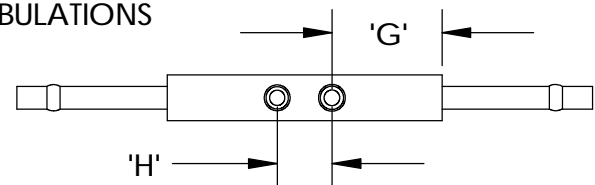

NOTE: .031 TUBES ARE NON-BULGED.

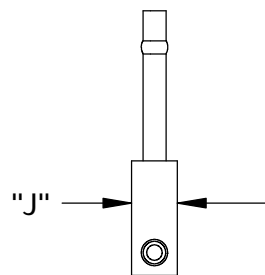
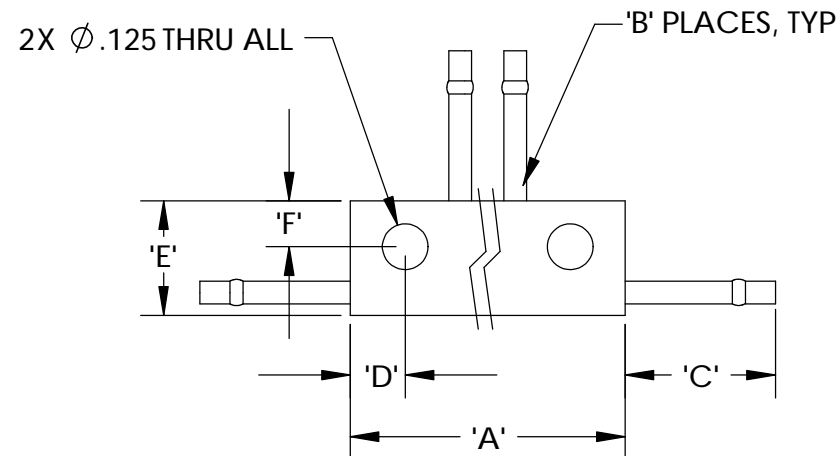

TC031-M2 COLOR (5958-1)

TC040-M2 COLOR (5073-1)

EXAMPLE: FOR A CONNECTOR WITH 5ea .093 TUBULATIONS (GOLD ANODIZE) TC093-M5 GLD

CATALOG #	'A'-.031	'A'-.040	'A'-.063	'A'-.093	'A'-.125	'B'
TCxxx-M2 COLOR	0.750	0.750	0.750	0.900	1.050	2
TCxxx-M3 COLOR	0.900	0.900	0.900	1.100	1.300	3
TCxxx-M4 COLOR	1.050	1.050	1.050	1.300	1.550	4
TCxxx-M5 COLOR	1.200	1.200	1.200	1.500	1.800	5
TCxxx-M6 COLOR	1.350	1.350	1.350	1.700	2.050	6
TCxxx-M7 COLOR	1.500	1.500	1.500	1.900	2.300	7
TCxxx-M8 COLOR	1.650	1.650	1.650	2.100	2.550	8
TCxxx-M9 COLOR	1.800	1.800	1.800	2.300	2.800	9
TCxxx-M10 COLOR	1.950	1.950	1.950	2.500	3.050	10
TCxxx-M11 COLOR	2.100	2.100	2.100	2.700	3.300	11
TCxxx-M12 COLOR	2.250	2.250	2.250	2.900	3.550	12

COLOR
GLD
BLK
GRN
RED
BLU
CLR

TC063-M2 COLOR (5083-x)

TC093-M2 COLOR (5088-1)

TC125-M2 COLOR (5093-1)

-1 TCxxx-Mxx SUMMARY DRAWING

UNLESS OTHERWISE SPECIFIED: DIMENSIONS ARE IN INCHES TOLERANCES: TWO PLACE DECIMAL ± .015 THREE PLACE DECIMAL ± .005 SHEETMETAL PARTS ± .010	DATE	11/8/2004	NAME	BCB
	DRAWN	11/8/2004	BCB	
	CHECKED	11/8/2004	AP	
	ENG APPR.	11/8/2004	DF	
	MFG APPR.	11/8/2004		
Q.A.	11/8/2004			
MATERIAL	COMMENTS:			
FINISH				
DO NOT SCALE DRAWING				

Scanivalve Corp. <small>LIBERTY LAKE, WA</small>		
TITLE: TCxxx-Mxx		
SUMMARY DRAWING		
SIZE	DWG. NO.	REV
B	81077	
SCALE: 1:1	ERO#:	SHEET 1 OF 1