

REVISIONS				
ZONE	REV.	DESCRIPTION	DATE	APPROVED

NOTES:
 1. ALL .031 DIAMETER TUBES ARE NON-BULGED.
 2. MATERIALS: CENTER BLOCK IS ALUMINUM AND TUBULATIONS ARE STAINLESS STEEL. FITTINGS ARE ASSEMBLED USING EPOXY.

CATALOG #
TC031-X
TC040-X
TC063-X
TC093-X
TC125-X

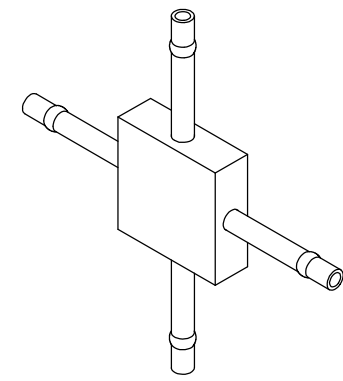

TC063-X SHOWN (5082-X)

CATALOG #
TC031-T
TC040-T
TC063-T
TC093-T
TC125-T

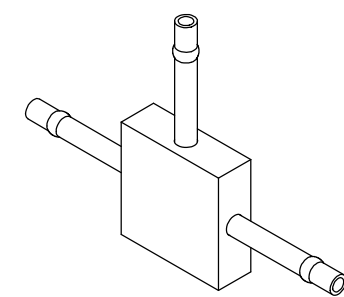

TC063-T SHOWN (5081-X)

CATALOG #
TC031-I
TC040-I
TC063-I
TC093-I
TC125-I

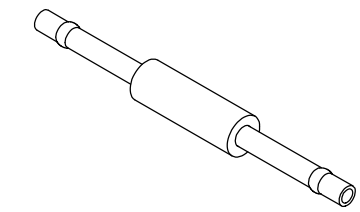

TC063-I SHOWN (5080-X)

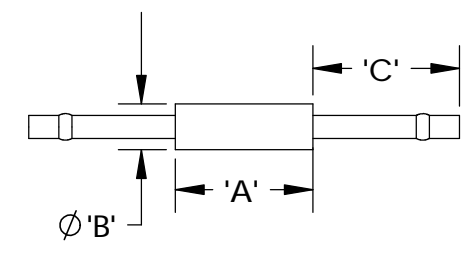
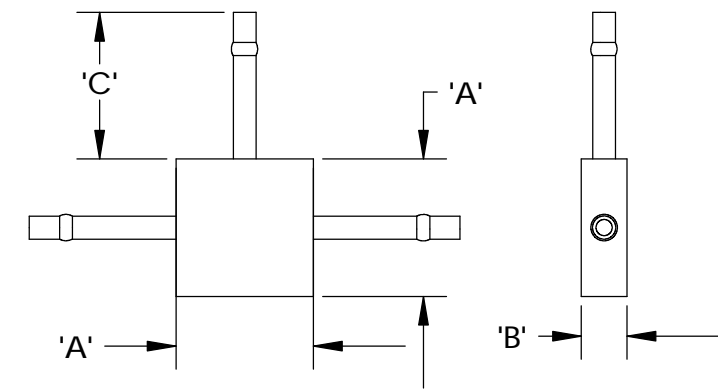
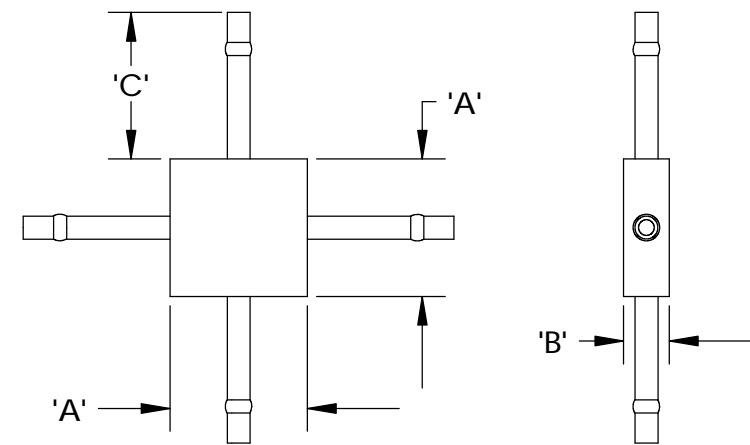

CATALOG #
TC031-P
TC040-P
TC063-P
TC093-P
TC125-P

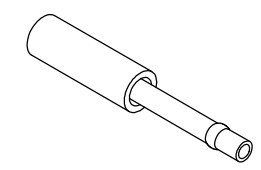

TC063-P SHOWN (5175-X)

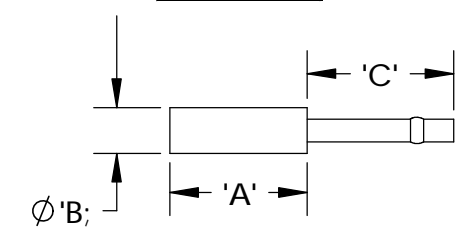

CATALOG #	'A'	'B'	'C'
TC031-	0.375	0.125	0.360
TC040-	0.375	0.125	0.400
TC063-	0.375	0.125	0.400
TC093-	0.500	0.187	0.400
TC125-	0.625	0.250	0.500

FINISH
GOLD
BLK
GRN
RED
BLU
CLR

-1 TC-xxx-X,T,P,I SUMMARY DRAWING

UNLESS OTHERWISE SPECIFIED: DIMENSIONS ARE IN INCHES TOLERANCES: TWO PLACE DECIMAL ± .015 THREE PLACE DECIMAL ± .005 SHEETMETAL PARTS ± .010	DRAWN	11/8/2004	BCB	
	CHECKED	11/8/2004	AE	
	ENG APPR.	11/8/2004	AP	
	MFG APPR.	11/8/2004	DF	
	Q.A.	11/8/2004		
MATERIAL	COMMENTS:			TITLE: TCxxx-X,T,P,I SUMMARY DRAWING
FINISH				SIZE B DWG. NO. 81079 REV
DO NOT SCALE DRAWING				SCALE: 2:1 ERO#: SHEET 1 OF 1