

**DTS3250/16Tx**  
SN 1100 and Higher  
**DTS3250/32Tx**  
**DTS3250/64Tx**  
**Thermocouple Scanners**  
**Instruction and Service Manual**  
Software Version DTS V4.19

8/2014

---

1722 North Madson Street  
Liberty Lake, WA 99019  
Tel: (800) 935-5151  
(509) 891-9970  
Fax: (509) 891-9481  
web site: [www.scanivalve.com](http://www.scanivalve.com)  
e-mail: [scanco@scanivalve.com](mailto:scanco@scanivalve.com)

***Scanivalve Corp.***

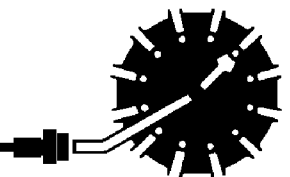

# Table of Contents

|  |                    |
|--|--------------------|
| Specifications.....                      | <a href="#">1</a>  |
| General Description.....                 | <a href="#">3</a>  |
| DTS3250 Versions.....                    | <a href="#">5</a>  |
| <b>Screw Terminal Version</b> .....      | <a href="#">5</a>  |
| <b>Panel Jack Version</b> .....          | <a href="#">5</a>  |
| <b>Panel Mount Version</b> .....         | <a href="#">5</a>  |
| Temperature Measurement Basics.....      | <a href="#">6</a>  |
| DTS Network/Firmware.....                | <a href="#">7</a>  |
| DTS3250/16Tx Dimensions.....             | <a href="#">8</a>  |
| DTS3250/32Tx Dimensions.....             | <a href="#">9</a>  |
| DTS3250/64Tx Dimensions.....             | <a href="#">10</a> |
| Calibration Requirements.....            | <a href="#">12</a> |
| Introduction.....                        | <a href="#">12</a> |
| Equipment Required.....                  | <a href="#">12</a> |
| Power Requirements.....                  | <a href="#">13</a> |
| Trigger Requirements.....                | <a href="#">14</a> |
| Hardware Trigger.....                    | <a href="#">14</a> |
| Software Trigger.....                    | <a href="#">14</a> |
| RS 232 Communications.....               | <a href="#">15</a> |
| Ethernet Connections.....                | <a href="#">16</a> |
| 10Base-T.....                            | <a href="#">16</a> |
| DTS Control and Configuration.....       | <a href="#">17</a> |
| DTS Commands.....                        | <a href="#">17</a> |
| Command List.....                        | <a href="#">18</a> |
| A/D CALIBRATION.....                     | <a href="#">18</a> |
| AUTOSTATUS.....                          | <a href="#">18</a> |
| CLEAR.....                               | <a href="#">19</a> |
| CLOSE HOST BINARY SERVER CONNECTION..... | <a href="#">19</a> |
| CONNECT TO HOST BINARY SERVER.....       | <a href="#">20</a> |
| CORRECT RTD VOLTAGE TABLES.....          | <a href="#">20</a> |
| ENTER CHANNEL CALIBRATION SETPOINTS..... | <a href="#">20</a> |
| ENTER CHANNEL CALIBRATION SETPOINTS..... | <a href="#">21</a> |
| ENTER RTD CALIBRATION SETPOINTS.....     | <a href="#">21</a> |
| ERROR.....                               | <a href="#">22</a> |
| FILL.....                                | <a href="#">22</a> |
| HOST BINARY SERVER COMMAND.....          | <a href="#">23</a> |
| ICE POINT OFFSET ADJUSTMENT.....         | <a href="#">23</a> |
| LIST CALIBRATION.....                    | <a href="#">23</a> |

|  |                    |
|--|--------------------|
| LIST CHANNEL CORRECTION SETPOINTS. ....      | <a href="#">24</a> |
| LIST CHANNEL CORRECTION SETPOINTS. ....      | <a href="#">24</a> |
| LIST CHANNEL DEFINITIONS. ....               | <a href="#">25</a> |
| LIST CONFIGURATION VARIABLES. ....           | <a href="#">25</a> |
| LIST GAIN. ....                              | <a href="#">25</a> |
| LIST IDENTIFICATION. ....                    | <a href="#">26</a> |
| LIST LABELS. ....                            | <a href="#">26</a> |
| LIST LIMITS. ....                            | <a href="#">27</a> |
| LIST NETWORK IDENTIFICATION. ....            | <a href="#">27</a> |
| LIST OFFSET. ....                            | <a href="#">28</a> |
| LIST RTD CORRECTION VALUES. ....             | <a href="#">28</a> |
| LIST RTD CONVERSION VALUES. ....             | <a href="#">29</a> |
| LIST RTD CURRENT CONVERSION VALUES. ....     | <a href="#">29</a> |
| LIST SCAN. ....                              | <a href="#">30</a> |
| LIST TYPE. ....                              | <a href="#">30</a> |
| LIST UTR CALIBRATION VARIABLES. ....         | <a href="#">31</a> |
| OPEN THERMOCOUPLE TEST. ....                 | <a href="#">31</a> |
| REBOOT. ....                                 | <a href="#">31</a> |
| SAVE. ....                                   | <a href="#">32</a> |
| SCAN. ....                                   | <a href="#">32</a> |
| SCAN TRIGGER. ....                           | <a href="#">34</a> |
| SET. ....                                    | <a href="#">34</a> |
| STATUS. ....                                 | <a href="#">35</a> |
| STOP. ....                                   | <a href="#">35</a> |
| UPLOAD. ....                                 | <a href="#">36</a> |
| VERSION. ....                                | <a href="#">36</a> |
| Configuration Variables. ....                | <a href="#">37</a> |
| Scan Variables (Group S). ....               | <a href="#">37</a> |
| AVG. ....                                    | <a href="#">37</a> |
| BIN. ....                                    | <a href="#">37</a> |
| FORMAT. ....                                 | <a href="#">37</a> |
| FPS. ....                                    | <a href="#">37</a> |
| PERIOD. ....                                 | <a href="#">38</a> |
| QPKTS. ....                                  | <a href="#">38</a> |
| RANGET. ....                                 | <a href="#">38</a> |
| RANGEV. ....                                 | <a href="#">38</a> |
| RATE. ....                                   | <a href="#">39</a> |
| TIME. ....                                   | <a href="#">39</a> |
| UNITS. ....                                  | <a href="#">39</a> |
| XSCANTRIG. ....                              | <a href="#">40</a> |
| Channel Correction Variables (Group P). .... | <a href="#">41</a> |
| PT. ....                                     | <a href="#">41</a> |
| PT. ....                                     | <a href="#">42</a> |
| Identification Variables (Group I). ....     | <a href="#">43</a> |
| AUTOCON. ....                                | <a href="#">43</a> |
| ECHO. ....                                   | <a href="#">43</a> |
| HOST. ....                                   | <a href="#">43</a> |
| HOSTCMD. ....                                | <a href="#">43</a> |
| PORT. ....                                   | <a href="#">44</a> |
| RTDMAXSLEW . ....                            | <a href="#">44</a> |
| TCMAXSLEW . ....                             | <a href="#">44</a> |
| TITLE1. ....                                 | <a href="#">44</a> |
| TITLE2. ....                                 | <a href="#">44</a> |
| Calibration Variables (Group C). ....        | <a href="#">45</a> |

|  |    |
|--|----|
| CALAVG.....  | 45 |
| NUMPTS.....  | 45 |
| NUMCOEF.....                                       | 45 |
| NUMTEMPS.....                                      | 45 |
| Network Identification Variables (Group ID).....   | 46 |
| IPADDRESS.....                                     | 46 |
| MODEL.....   | 46 |
| SERNUM.....  | 46 |
| VER.....   | 46 |
| Channel Identification Variables (Group DEF).....  | 46 |
| DEF <channel>.....                                 | 46 |
| Limit Variables (Group LI).....                    | 47 |
| LIMIT.....   | 47 |
| Channel Labels (Group LA).....                     | 47 |
| LABEL.....   | 47 |
| Thermocouple Variables (Group T).....              | 48 |
| TYPE <channel> <type> [shield connect].....        | 48 |
| RTD Correction Variables (Group RPC).....          | 50 |
| RPC <channel>.....                                 | 50 |
| RTD Conversion Volts to Ohms (Group RTD).....      | 51 |
| RTD 1 <R0>.....                                    | 51 |
| RTD 2 <R0>.....                                    | 51 |
| RTD 3 <R0>.....                                    | 51 |
| RTD 4 <R0>.....                                    | 51 |
| RTD 5 <R0>.....                                    | 52 |
| RTD 6 <R0>.....                                    | 52 |
| RTD 7 <R0>.....                                    | 52 |
| RTD 8 <R0>.....                                    | 52 |
| Channel Gain Correction Variables (Group G).....   | 53 |
| GAIN.....  | 53 |
| Channel Offset Correction Variables (Group O)..... | 53 |
| OFFSET.....  | 53 |
| RTD Calibration Variables (Group U).....           | 54 |
| ARPC.....  | 54 |
| ARPCON.....  | 54 |
| MAXDELTA.....                                      | 54 |
| RNUMPTS.....                                       | 54 |
| RNUMCOEF.....                                      | 54 |
| DTS Packet Definitions.....                        | 55 |
| Packet Type Table.....                             | 55 |
| Host Control Packets.....                          | 55 |
| Command Packet.....                                | 55 |
| DTS to HOST.....                                   | 56 |
| Binary Data Packets.....                           | 56 |
| DTS3250/16 Channel Module.....                     | 56 |
| DTS3250/32 Channel Module.....                     | 57 |
| DTS3250/64 Channel Module.....                     | 58 |
| General Status Byte.....                           | 59 |
| Channel Status Byte.....                           | 60 |
| ASCII Data Packet.....                             | 61 |
| Network Protocols Supported.....                   | 61 |

|  |                    |
|--|--------------------|
| Operation.....   | <a href="#">62</a> |
| Ethernet Connections.....  | <a href="#">62</a> |
| IP Address.....  | <a href="#">62</a> |
| Network Identification.....                                      | <a href="#">62</a> |
| TelNet Host Operation - Windows 95 and 98.....                   | <a href="#">63</a> |
| HyperTerminal Ethernet Operation - Windows NT, 2000, and XP..... | <a href="#">63</a> |
| DTS3250 Recommended Operation.....                               | <a href="#">64</a> |
| Special Operational Notes.....                                   | <a href="#">64</a> |
| DTS3250 Boot Parameter Modification.....                         | <a href="#">65</a> |
| Boot parameters and their functions.....                         | <a href="#">67</a> |
| DTS3250 Operating System Upload.....                             | <a href="#">68</a> |
| DTS3250 Buffer Description.....                                  | <a href="#">68</a> |
| WarFTP Server.....   | <a href="#">69</a> |
| Installation.....  | <a href="#">69</a> |
| Configuration and Setup.....                                     | <a href="#">71</a> |
| Appendix A - Accessories.....                                    | <a href="#">76</a> |
| Power Supply - PDM 1500.....                                     | <a href="#">76</a> |
| Power Supply - PDM 3200.....                                     | <a href="#">77</a> |
| Appendix B - Thermocouple Information.....                       | <a href="#">78</a> |
| Thermocouple Basics.....   | <a href="#">78</a> |
| Law of Homogeneous Materials.....                                | <a href="#">78</a> |
| Law of Intermediate Materials.....                               | <a href="#">78</a> |
| Law of Successive or Intermediate Temperature.....               | <a href="#">78</a> |
| Thermocouple Circuits.....                                       | <a href="#">78</a> |
| Thermocouple Accuracy.....                                       | <a href="#">79</a> |
| Relative Accuracy.....   | <a href="#">79</a> |
| Absolute Accuracy.....   | <a href="#">79</a> |
| Thermocouple Calibration.....                                    | <a href="#">79</a> |
| Sources of Error in Thermocouple Measurements.....               | <a href="#">79</a> |
| Measuring Junction.....  | <a href="#">79</a> |
| Extension Wires.....   | <a href="#">79</a> |
| Reference Junctions.....   | <a href="#">80</a> |
| Copper Connecting Wires.....                                     | <a href="#">80</a> |
| Thermocouple Switches.....                                       | <a href="#">80</a> |
| Noise in Thermocouple Circuits.....                              | <a href="#">80</a> |
| Thermocouple Design.....   | <a href="#">81</a> |
| Size.....  | <a href="#">81</a> |
| Shape.....   | <a href="#">81</a> |
| Response.....  | <a href="#">81</a> |
| Heat Conduction.....   | <a href="#">81</a> |
| Sensor Position.....   | <a href="#">81</a> |
| Thermocouple Types and Descriptions.....                         | <a href="#">81</a> |
| Type B.....  | <a href="#">81</a> |
| Type E - Chromel Constantan.....                                 | <a href="#">81</a> |
| Type J - Iron Constantan.....                                    | <a href="#">82</a> |
| Type K - Chromel Alumel.....                                     | <a href="#">82</a> |
| Type N.....  | <a href="#">82</a> |

|   |                    |
|---|--------------------|
| Type R. ....  | <a href="#">82</a> |
| Type S. ....  | <a href="#">82</a> |
| Type T - Copper Constantan. ....                                | <a href="#">82</a> |
| International Thermocouple and Extension Wire Color Codes. .... | <a href="#">83</a> |
| Appendix C - DTS3250 Error List. ....                           | <a href="#">84</a> |
| Bootup/Initialization Errors. ....                              | <a href="#">84</a> |
| Configuration Variable Errors. ....                             | <a href="#">84</a> |
| Command Errors. ....  | <a href="#">91</a> |
| Communication/Hardware Errors. ....                             | <a href="#">91</a> |
| Appendix D - Software Change Log. ....                          | <a href="#">94</a> |

## Figures and Illustrations

|   |                    |
|---|--------------------|
| Figure 1 - DTS3250/16Tx Both Versions. ....                             | <a href="#">3</a>  |
| Figure 2 - DTS3250/32Tx Screw Terminal Version. ....                    | <a href="#">4</a>  |
| Figure 3 - DTS3250/64Tx Screw Terminal Version. ....                    | <a href="#">4</a>  |
| Figure 4 - DTS3250 Block Diagram. ....                                  | <a href="#">6</a>  |
| Figure 5 - Typical Pressure/Temperature Scanning System. ....           | <a href="#">7</a>  |
| Figure 6 - DTS3250/16 Dimensions. ....                                  | <a href="#">8</a>  |
| Figure 7 - DTS3250/32Tx Dimensions. ....                                | <a href="#">9</a>  |
| Figure 8 - DTS3250/64TX Dimensions. ....                                | <a href="#">10</a> |
| Figure 9 - DTS3250/64Tx Panel Mount. ....                               | <a href="#">11</a> |
| Figure 10 - Digital Sensor Array Power Wiring. ....                     | <a href="#">13</a> |
| Figure 11 - DTS3250/16 Typical Inrush Current. ....                     | <a href="#">13</a> |
| Figure 12 - Trigger wiring. ....  | <a href="#">14</a> |
| Figure 13 - RS232/ External Trigger Test Cable. ....                    | <a href="#">15</a> |
| Figure 14 - DTS3250 10Base-T cables. ....                               | <a href="#">16</a> |
| Figure 15 - Bonded Thermocouple, No Shield. ....                        | <a href="#">48</a> |
| Figure 16 - Unbonded Thermocouple, No Shield. ....                      | <a href="#">48</a> |
| Figure 17 - Shielded Thermocouple, Shield connected at the DTS. ....    | <a href="#">49</a> |
| Figure 18 - Shielded Thermocouple, Shield connected at the source. .... | <a href="#">49</a> |
| Figure 19 - Unterminated Probe. ....                                    | <a href="#">49</a> |

## Tables

|                                     |                    |
|-------------------------------------|--------------------|
| Table 1 - General Status Byte. .... | <a href="#">59</a> |
| Table 2 - Channel Status Byte. .... | <a href="#">60</a> |
| Table 3 - RTD Units. ....           | <a href="#">60</a> |

## Command List

|   |                    |
|---|--------------------|
| ADCAL.....  | <a href="#">18</a> |
| AUTOSTATUS.....   | <a href="#">18</a> |
| CLEAR.....  | <a href="#">19</a> |
| CLOBIN.....   | <a href="#">19</a> |
| CONBIN.....   | <a href="#">20</a> |
| ARPC <Reference Temperature> <board> .....                            | <a href="#">20</a> |
| PT <index> <volts> [channel] .....                                    | <a href="#">21</a> |
| PT <T    R> <chan/board> <temp ndx> <temp> <pt ndx> <act volts> ..... | <a href="#">21</a> |
| RPC <index> <volts> <board> .....                                     | <a href="#">22</a> |
| ERROR .....   | <a href="#">22</a> |
| FILL.....   | <a href="#">22</a> |
| HOST <command>.....   | <a href="#">23</a> |
| IPO <start channel> <end channel>.....                                | <a href="#">23</a> |
| LIST C.....   | <a href="#">23</a> |
| LIST P <channel>.....   | <a href="#">24</a> |
| LIST P [<T    R> <chan/board>.....                                    | <a href="#">24</a> |
| LIST DEF <channel>.....   | <a href="#">25</a> |
| LIST A.....   | <a href="#">25</a> |
| LIST G.....   | <a href="#">25</a> |
| LIST I.....   | <a href="#">26</a> |
| LIST LA.....  | <a href="#">26</a> |
| LIST LI.....  | <a href="#">27</a> |
| LIST ID.....  | <a href="#">27</a> |
| LIST O.....   | <a href="#">28</a> |
| LIST RPC <board>.....   | <a href="#">28</a> |
| LIST RTDP.....  | <a href="#">29</a> |
| LIST RTDX.....  | <a href="#">29</a> |
| LIST S.....   | <a href="#">30</a> |
| LIST T.....   | <a href="#">30</a> |
| LIST U.....   | <a href="#">31</a> |
| OTC.....  | <a href="#">31</a> |
| REBOOT .....  | <a href="#">31</a> |
| SAVE .....  | <a href="#">32</a> |
| SCAN .....  | <a href="#">32</a> |
| TRIG .....  | <a href="#">34</a> |
| SET <name> <value>.....   | <a href="#">34</a> |
| STATUS.....   | <a href="#">35</a> |
| STOP .....  | <a href="#">35</a> |
| UPLOAD <S or C><filepath/filename> .....                              | <a href="#">36</a> |
| VER .....   | <a href="#">36</a> |

# Configuration Variables

|  |    |
|--|----|
| Scan Variables (Group S)                               | 37 |
| AVG <value>  | 37 |
| BIN <code>   | 37 |
| FORMAT <code>  | 37 |
| FPS <value>  | 37 |
| PERIOD <value>   | 38 |
| QPKTS <code>   | 38 |
| RANGET <low range temp value> <high range temp value>  | 38 |
| RANGEV <low range volt value> <high range volt value>  | 38 |
| RATE <value>   | 39 |
| TIME <code>  | 39 |
| UNITS <type>   | 39 |
| XSCANTRIG <code>                                       | 40 |
| Channel Correction Variables (Group P)                 | 41 |
| PT <channel> <index> <volts applied> <counts applied>  | 41 |
| PT <T    R> <chan/board> <temp ndx> <temp>             | 42 |
| Identification Variables (Group I)                     | 43 |
| AUTOCON <code>   | 43 |
| ECHO <code>  | 43 |
| HOST <IP address> <port> <protocol>                    | 43 |
| HOSTCMD <ASCII string>                                 | 43 |
| PORT xxxx  | 44 |
| RTD_MAXSLEW <value>                                    | 44 |
| TC_MAXSLEW <value>                                     | 44 |
| TITLE1 <title>   | 44 |
| TITLE2 <title>   | 44 |
| Calibration Variables (Group C)                        | 45 |
| CALAVG <value>   | 45 |
| NUMPTS <points>  | 45 |
| NUMCOEF <coef>   | 45 |
| NUMTEMPS <numtemps>                                    | 45 |
| Network Identification Variables (Group ID)            | 46 |
| IPADDRESS <ip address>                                 | 46 |
| MODEL <model number/channels>                          | 46 |
| SERNUM <serial number>                                 | 46 |
| VER <version number>                                   | 46 |
| Channel Identification Variables (Group DEF)           | 46 |
| DEF <channel> <definition>                             | 46 |
| Limit Variables (Group LI)                             | 47 |
| LIMIT <channel> <enable> [<high limit> <low limit>]    | 47 |
| Channel Labels (Group LA)                              | 47 |
| LABEL <channel> <label>                                | 47 |
| Thermocouple Variables (Group T)                       | 48 |
| TYPE <channel> <type> [shield connect]                 | 48 |
| RTD Correction Variables (Group RPC)                   | 50 |
| RPC <channel> <index> <volts applied> <counts applied> | 50 |
| RTD Conversion Volts to Ohms (Group RTD)               | 51 |
| RTD 1 <R0> <A> <B>                                     | 51 |
| RTD 2 <R0> <A> <B>                                     | 51 |
| RTD 3 <R0> <A> <B>                                     | 51 |
| RTD 4 <R0> <A> <B>                                     | 51 |
| RTD 5 <R0> <A> <B>                                     | 52 |
| RTD 6 <R0> <A> <B>                                     | 52 |



|  |                    |
|--|--------------------|
| RTD 7 <R0> <A> <B>.....                            | <a href="#">52</a> |
| RTD 8 <R0> <A> <B>.....                            | <a href="#">52</a> |
| Channel Gain Correction Variables (Group G).....   | <a href="#">53</a> |
| GAIN <channel> <gain value>.....                   | <a href="#">53</a> |
| Channel Offset Correction Variables (Group O)..... | <a href="#">53</a> |
| OFFSET <channel> <gain value>.....                 | <a href="#">53</a> |
| RTD Calibration Variables (Group U).....           | <a href="#">54</a> |
| ARPC <board> <value>.....                          | <a href="#">54</a> |
| ARPCON <value>.....                                | <a href="#">54</a> |
| MAXDELTA <value>.....                              | <a href="#">54</a> |
| RNUMPTS <points>.....                              | <a href="#">54</a> |
| RNUMCOEF <coef>.....                               | <a href="#">54</a> |

## Specifications

|                                      |  |
|--------------------------------------|--|
| <b>Inputs (Tx):</b>                  | 16, 32 , or 64 pairs of screw terminals plus shields.<br>Optional Panel Jack connections available |
| <b>Thermocouple Types:</b>           | B, E, J, K, N, R, S, and T   |
| <b>DTS3250 Accuracy<sup>1</sup>:</b> |  |
| E, J, K, N and T                     | ±0.5°C   |
| R and S                              | ±2.0°C   |
| B (400°C to 1800°C)                  | ±4.0°C   |
| <b>UTR Accuracy:</b>                 | ±0.1°C   |
| <b>A/D Resolution:</b>               | 22 Bit (Each channel)  |
| <b>Scan Rate:</b>                    |  |
| DTS3250/16Tx                         | 40 samples/channel/second  |
| DTS3250/32Tx                         | 20 samples/channel/second  |
| DTS3250/64Tx                         | 10 samples/channel/second  |
| <b>Operating Temperature:</b>        |  |
| Without Heater                       | -10°C to 60°C  |
| With Heater                          | -20°C to 60°C (16 and 32 channel versions only)  |
| <b>Communication:</b>                | Ethernet 10Base-T (standard)<br>RS-232 (Configuration Only)  |
| <b>Communication Protocol:</b>       | TCP/IP or UDP  |
| <b>Mating Connector Type:</b>        |  |
| Ethernet                             | Bendix PT06A-8-4S-SR, 4 pin female   |
| Power                                | Bendix PTO6A-8-3S-SR, 3 pin female   |
| Trigger/Configuration                | Bendix JTO6RE8-6S-SR, 6 pin female   |
| <b>Power (21-36Vdc):</b>             |  |
| DTS3250/16Tx                         |  |
| Standard                             | 28Vdc nominal @, 9 VA quiescent  |
| With Heater                          | 28Vdc nominal @, 70 VA during warmup   |
| DTS3250/32Tx                         |  |
| Standard                             | 28Vdc nominal @, 14 VA quiescent   |
| With Heater                          | 28Vdc nominal @, 140 VA during warmup  |
| DTS3250/64Tx                         |  |
| Standard                             | 28Vdc nominal @, 27 VA quiescent   |
| With Heater                          | Heater Option not available for 64 channel models  |
| <b>External Trigger:</b>             | 9 to 15 Vdc @ 6.5 mA minimum, leading edge sensing   |
| <b>Common Mode Rejection:</b>        | 160 db @ 0 - 60 Vdc  |

**Weight:**

|              |                                      |
|--------------|--------------------------------------|
| DTS3250/16Tx | Standard Unit: 13.0 pounds(5.91 kg)  |
|              | Panel Jacks: 12.0 pounds(5.45 kg)    |
| DTS3250/32Tx | Standard Unit: 14.5 pounds(6.59 kg)  |
|              | Panel Jacks: 14.0 pounds(6.36 kg)    |
| DTS3250/64Tx | Standard Unit: 25.0 pounds(11.36 kg) |
|              | Rack Mount: 28.0 pounds(12.73 kg)    |

**Input/Output Isolation:** 1000 Vdc

**CE Mark Standards<sup>2</sup>:** IEC 1000-4.2, 1000-4.3, 1000-4.5

<sup>1</sup> System accuracy specifications are valid after a three(3) hour warm up period.

Accuracy does not include Thermocouples, Thermocouple Extension Wire, or the Panel Jack option.

<sup>2</sup> CE Mark certification applies to the screw terminal versions only.

## General Description

The DTS3250 series thermocouple acquisition system represents the next generation of Intelligent temperature scanning. This Digital Thermocouple Scanner incorporates 16, 32 or 64 pair of thermocouple inputs, An 22 bit A/D converter for each input channel, RAM, and a micro-processor, in a rugged temperature controlled stand alone module.

An Isothermal block is incorporated for the Uniform Temperature Reference (UTR), with a  $\pm 0.1^{\circ}\text{C}$  accuracy. NIST thermocouple tables for standard thermocouple types are stored in Flash Memory. The microprocessor uses these look-up tables to convert mV inputs to Engineering units. Temperature data may be output in  $^{\circ}\text{C}$ ,  $^{\circ}\text{F}$ ,  $^{\circ}\text{R}$ , K, Volts, or A/D counts .

The DTS3250 total system error is  $\pm 0.2^{\circ}\text{C}$  for E, J, K, and N thermocouples, not including extension wire and external connectors, or panel jacks..

Multiple standard thermocouple types may be used with this intelligent thermocouple scanner. The DTS 3250 can accept grounded and un-grounded thermocouples.



Figure 1 - DTS3250/16Tx Both Versions



Figure 2 - DTS3250/32Tx Screw Terminal Version



Figure 3 - DTS3250/64Tx Screw Terminal Version

## **DTS3250 Versions**

### **Screw Terminal Version**

This is the standard configuration for all DTS3250 modules. DTS3250 modules are available in versions that will accept 16, 32 or 64 shielded thermocouples. The top cover and insulation isolate the UTR from small temperature changes giving this unit the best accuracy. This unit also has CE Mark certification for both Heavy and Light Industrial. The 16 channel version is shown in Figure 1. Dimensions of the DTS3250/16Tx are shown in Figure 6. Dimensions of the DTS3250/32Tx are shown in Figure 7. Dimensions of the DTS3250/64Tx are shown in Figure 8.

### **Panel Jack Version**

DTS 3250 modules may have panel jacks installed as an option in all versions. This option is available for type E, J, K, and T Thermocouples only. This option has a reduced accuracy of  $\pm 2.0^{\circ}\text{C}$ . This error may be calibrated out by a user using the Gain and Offset terms. CE Mark certification is not available for this configuration. A 16 channel type K panel jack version is shown in Figure 1. Unused panel jacks must be plugged to prevent “cold spots” on the UTR which will cause errors.

### **Panel Mount Version**

DTS 3250/64Tx modules may be ordered in either the standard shock mount configuration or in an optional Panel mount configuration.. The Panel Mount configuration is designed to be mounted in a standard 19 inch rack mount cabinet. The mounting ears may be reversed to facilitate mounting. This configuration is shown in Figure 9.

## Temperature Measurement Basics

A thermocouple is a temperature sensor consisting of two leads made from different materials. The two leads are connected at one end, which is the measuring point of the thermocouple. The other end of the leads is connected to the DTS3250 cold junction (UTR).

The thermocouple output is a mV signal, typically called Electromotive Force (EMF). The EMF is a function of the difference of the dissimilar metals at the temperature source. The relation between EMF and temperature difference depends on the materials in the two thermocouple leads.

There are a number of standardized thermocouple types available on the market. Each has different properties, which makes them more or less suitable for different temperature ranges and applications.

Accuracy of a thermocouple measurement is highly dependent upon the reference junction connection, its material installation techniques, and temperature.

The DTS3250 intelligent thermocouple scanner measures the mV signal from the thermocouples and compensates for the temperature of the cold junction .

NIST ITS-90 mV-temperature tables for each type thermocouple listed in this manual are stored in the DTS3250 memory. The DTS3250 microprocessor utilizes the compensated EMF and the NIST look-up table for conversion to engineering units. Temperature data are then output via Ethernet with TCP/IP protocol.

Refer to Appendix A for more information on Thermocouples.

Figure 4 below shows a function block diagram of the DTS 3250.

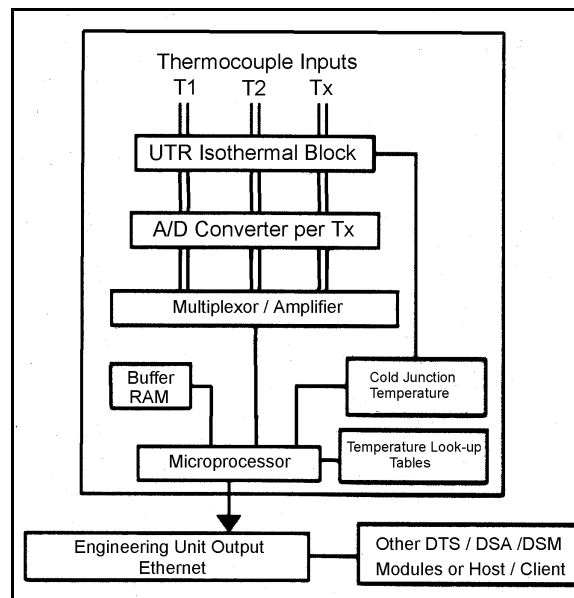

Figure 4 - DTS3250 Block Diagram

## DTS Network/Firmware

DTS3250 modules accept software commands via Ethernet only. The DTS3250 modules may be controlled with an external hardware or software scan trigger.

Each DTS module has a unique factory set 48 bit MAC address. When running TCP/IP protocol, the DTS3250 modules support ARP (Address Resolution Protocol) to enable the client/host to determine the relationship between the IP address and the Ethernet address. The IP address is user assignable.

All scan and calibration variables are configured through software by the user. This includes number of frames per scan, number of averages per frame, sampling speed, etc.

The DTS3250 firmware includes an open thermocouple test and an A/D re-zero function. The firmware contains Field calibrations which can be used to modify coefficients which can improve end to end accuracy. The RS232 communication connection may be used for firm ware uploads and network configuration only. This connector also contains the external trigger input connections.

Figure 5 below shows a typical Pressure and Temperature Scanning system.

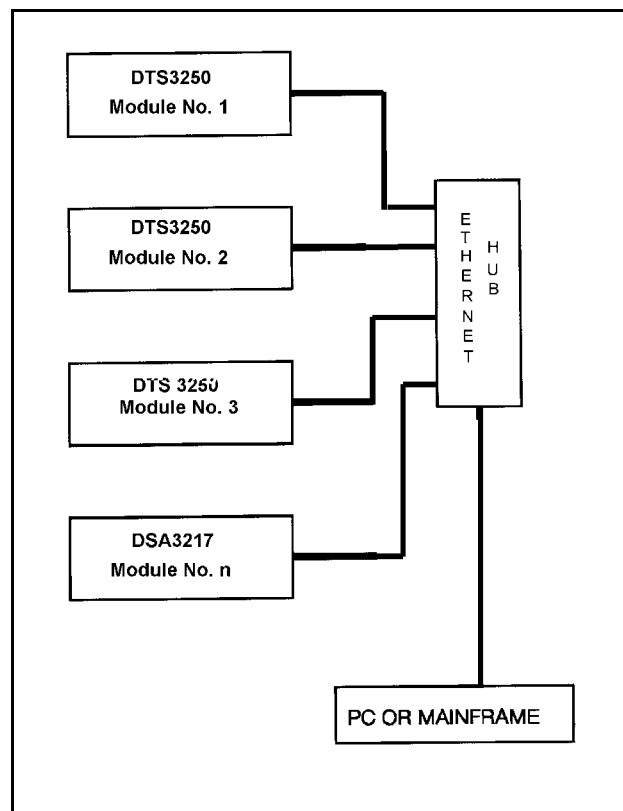
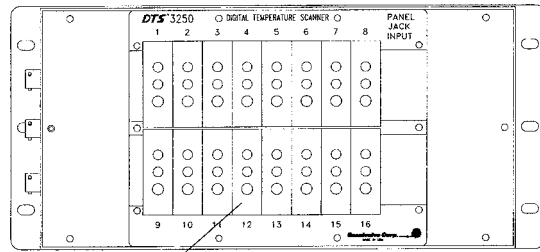
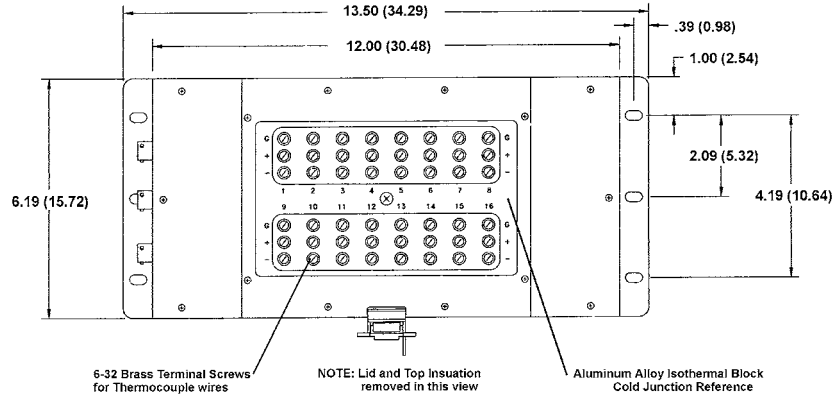

Figure 5 - Typical Pressure/Temperature Scanning System



# DTS3250/16Tx Dimensions



Three terminal Panel Jack connectors mounted directly to the Aluminum IsoThermal Block  
NOTE: Lid and Top Insulation are removed in this configuration

Standard Version End View  
Not Shown

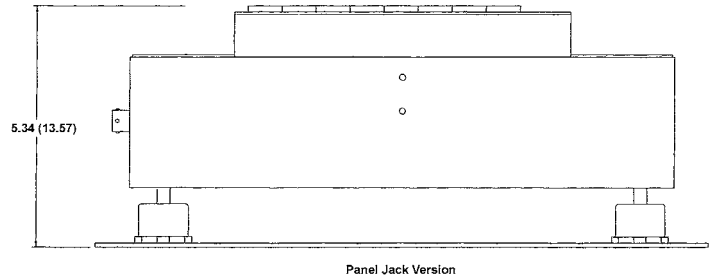
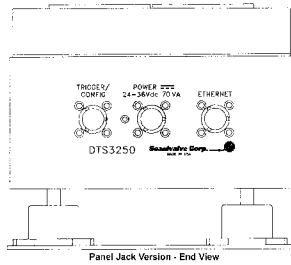
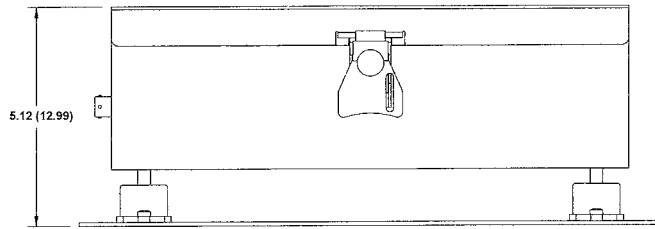

Figure 6 - DTS3250/16 Dimensions

# DTS3250/32Tx Dimensions

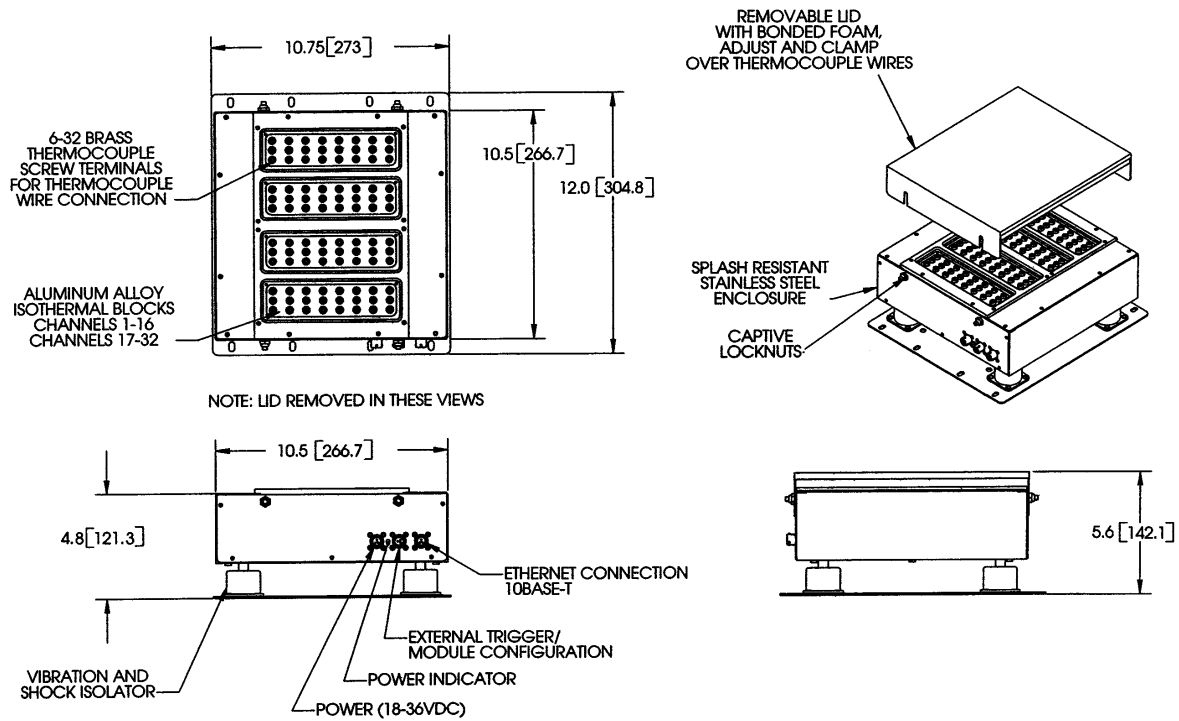

Figure 7 - DTS3250/32Tx Dimensions

# DTS3250/64Tx Dimensions

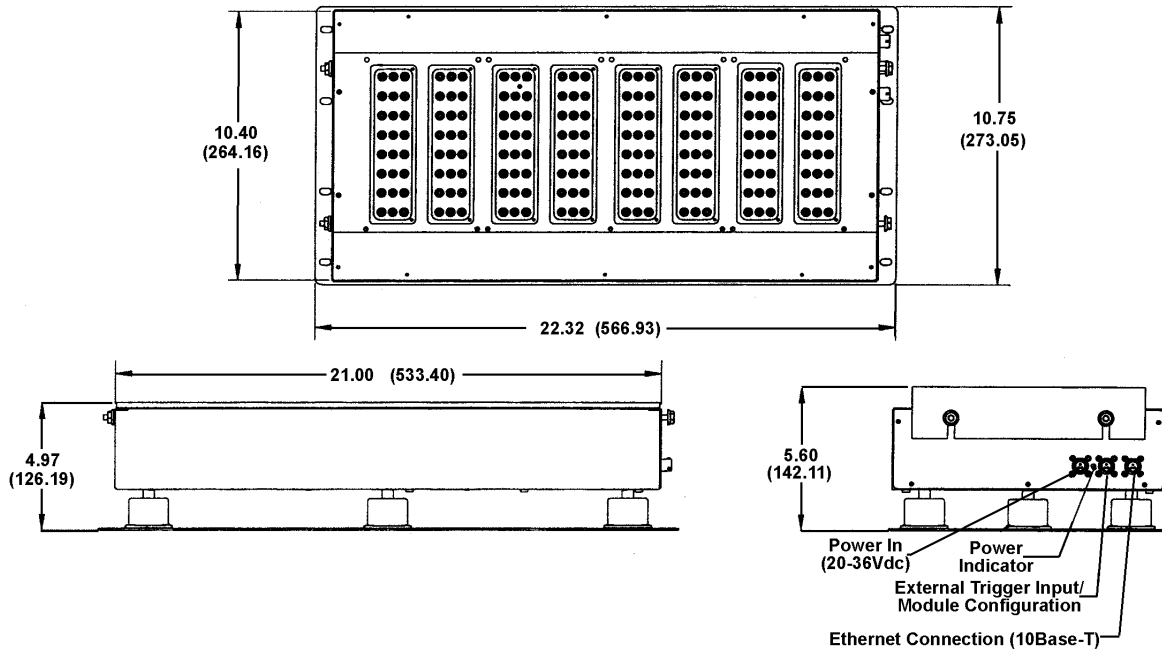

Figure 8 - DTS3250/64TX Dimensions

**DTS3250/64Tx Panel Mount**

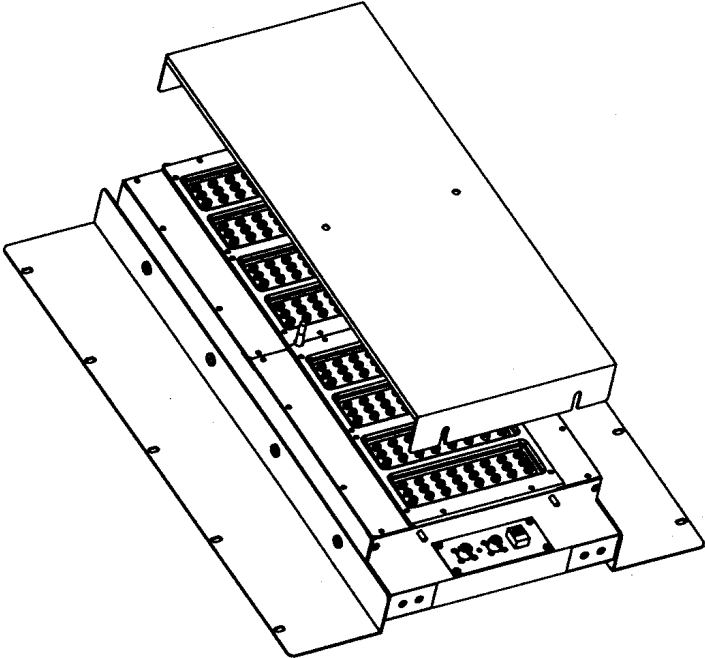

Figure 9 - DTS3250/64Tx Panel Mount

# Calibration Requirements

## Introduction

All DTS 3250 Thermocouple Scanner Modules are calibrated before they are shipped. The calibration is traceable to NIST. A certificate of Conformance is provided with each unit. Calibration data for each module are maintained in a history file at Scanivalve Corp. These data will be supplied to a customer , if requested.

All DTS3250 Thermocouple Scanner modules must be re-calibrated every six months in order to maintain accuracy. Calibrations may be performed at the Scanivalve factory, or by a customer. Customers who wish to perform their own calibrations should use a free Scanivalve Corp utility program, **TEMPCAL**. This program may be downloaded from the Scanivalve Corp website: [www.scanivalve.com](http://www.scanivalve.com)

## Equipment Required

In order to maintain NIST traceability, customer standards must meet the following criteria:

|                              |  |
|------------------------------|--|
| Secondary Voltage Standard - | Accuracy equal to or better than $\pm 1.5 \mu\text{V}$ from -10 mV to 131 mVdc |
| Digital Volt/Ohmmeter -      | Accuracy equal to or better than $\pm 10 \mu\text{V}$ from 95 mV to 105 mV dc  |
| 100 ohm Standard Resistor -  | Measured value accurate to $\pm 0.001\%$                                       |

Additional equipment required:

- Ice Point Reference
- Thermocouple Simulator
- DTS3250 Hardware and Software Manual
- Scanivalve Field Calibration Kit - Scanco P/N: 21079, Consisting of:
  - 155870-1 DTS Calibration Board Set (a)
  - 155868-1 DTS RTD Extension Cable
  - 155869-1 RTD Measurement Cable
  - 21089-1 Calibration Insulation
  - 155386-1 TempCal software

**Warning:** It is very important that proper ESD precautions are followed when the DTS calibration board set is being installed or removed, or whenever cables are connected and disconnected.

## Power Requirements

All DTS3250 modules require  $+28\pm 4\text{Vdc}$  for an input voltage. The current requirements for each model may be found on the Specifications Pages. For modules with optional heaters used in an environment where the ambient temperature is  $10^\circ\text{C}$  or less, current requirements could remain high. Power connections are made through a three pin connector located on the side of the module. The pinouts of the connector may be found in figure 10. The mating connector is a PT06A-8-3S-SR.

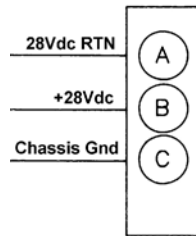

CO-613

Figure 10 - Digital Sensor Array Power Wiring

The power supply used to drive the DTS3250/16 must be capable of providing up to 2.5A initially at power up. The figure below shows the typical current inrush for a 16 channel DTS3250.

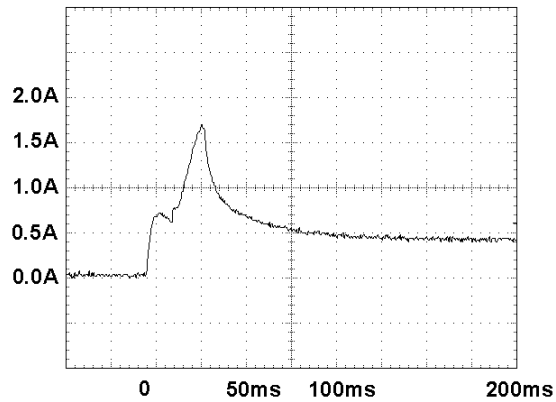

Figure 11 - DTS3250/16 Typical Inrush Current

# Trigger Requirements

## Hardware Trigger

The DTS3250 scan functions may be synchronized with other data acquisition devices by using the external trigger. The external trigger input is opto-isolated to prevent grounding problems. It is a TTL level, edge sensing device. It requires a minimum signal of 9Vdc @ 6.5 mA. It may accept voltages as high as 15 Vdc.

The external trigger will only be active if the XSCANTRIG variable is set to 1. When a SCAN command is issued by the Client/Host, the module will enter the SCAN mode and wait for a trigger. An averaged frame of data will be output as soon as the minimum trigger edge level is achieved. Data will be output with each successive trigger pulse to the FPS variable (Frames per Scan) value or until a STOP command is issued.

DTS3250 Modules use a 6 pin connector for a combination Trigger and Serial Communications Interface. The wiring is shown in figure 12. The mating connector is a JT06RE8-6S-SR (Scanco Pn CO-737) .

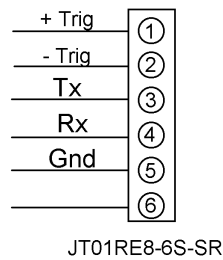

Figure 12 - Trigger wiring

## Software Trigger

The DTS3250 may also be triggered with a software trigger. The software trigger will only be active if the XSCANTRIG variable is set to 1. When a SCAN command is issued by the Client/Host, the module will enter the SCAN mode and wait for a trigger. An averaged frame of data will be output as soon as the TRIG command or a <TAB> character (9 HEX or Control I) is received. Data will be output with each successive trigger command to the FPS variable (Frames per Scan) value or until a STOP command is issued.

## RS 232 Communications

Every DTS3250 Module has a RS 232 output. It is available at the Serial Communications/Trigger Connector. It is required to configure the module IP address, or upload operating system upgrades. The wiring of the RS 232 output is shown in figure 13.

The RS232 inputs and outputs are not opto-isolated. Therefore, the RS232 connection could cause ground loops if it is connected during data acquisitions. Because the RS232 connection is only used for initial configuration, there is no need to maintain the connection after that setup is completed unless the external trigger function will be used.

If the RS232 connection is part of a combination Serial/Trigger cable, the RS232 connection at the host computer should be disconnected during data operations to prevent problems.

A combination RS232 and External Trigger test cable(Scanco PN 155829) is available as an option. The cable is shown below along with a wiring diagram.

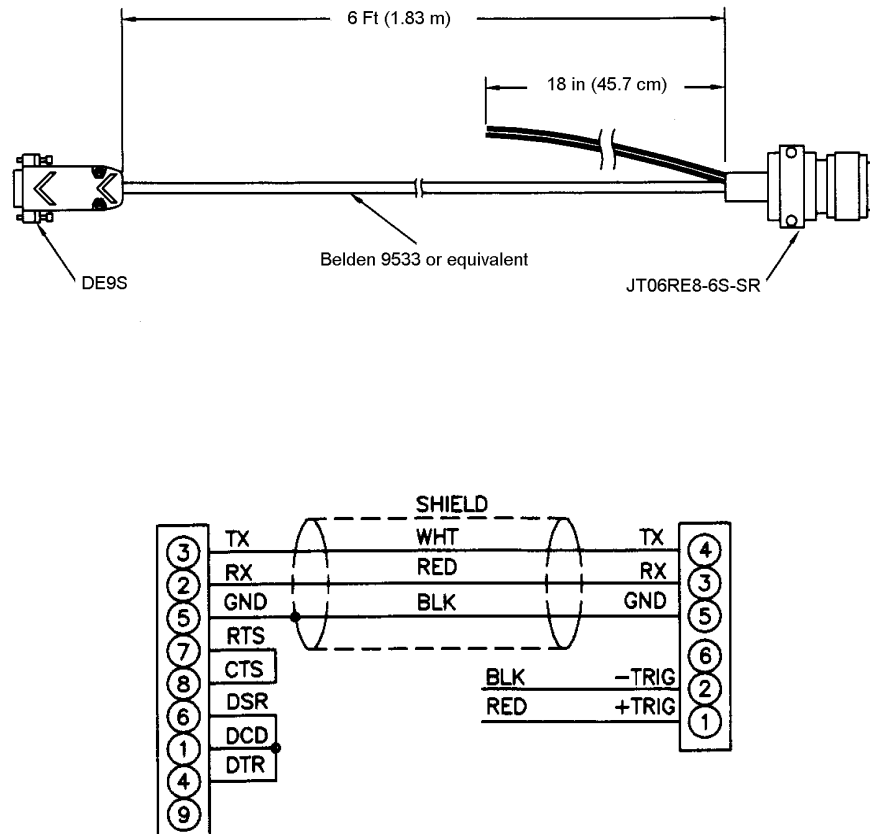

Figure 13 - RS232/ External Trigger Test Cable



# Ethernet Connections

The DTS3250 has provisions for 10Base-T Ethernet connections only. Ethernet 10Base-2 connections may be made with media converters.

## 10Base-T

The 10Base-T connection uses a Bendix connector at the module, which must be interfaced to the standard RJ-45 connector. A 10Base-T connection may be straight through (pin to pin) or crossover. A straight through cable must be used if the module is connected to a hub. Crossover connections are used if the module is connected directly to the host computer. It is recommended that Category Five cables be used. The maximum length for 10Base-T cables is 100 meters, but signal strength can be attenuated at this distance. A repeater is required for 10Base-T cable runs greater than 100 meters. Cables may be ordered from Scanivalve Corp. The pin to pin cable part number is 155820-01. The crossover cable part number is 155859-01. The cable length must be specified when the cable is ordered.

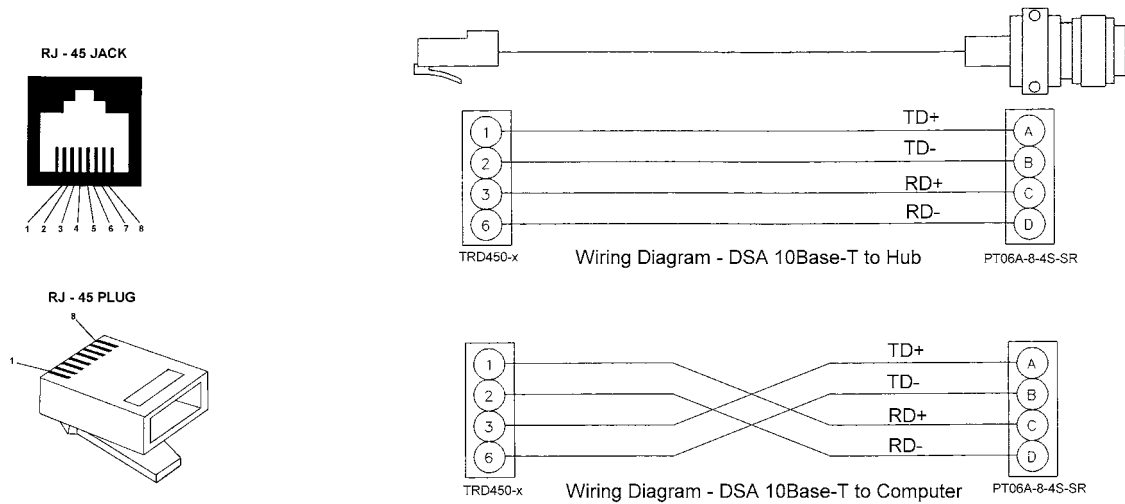

Figure 14 - DTS3250 10Base-T cables

## DTS Control and Configuration

The operation of each DTS is controlled by sending ASCII commands over the TelNet port(port 23) to units selected by network addressing. The DTS returns any data or information over the network to the requesting client/host in ASCII or Binary format depending upon the settings of a configuration variable. Binary data transfers are delivered across an additional binary transfer port.

Binary transfers may be in TCP or UDP protocol. TCP requires that a Host provide a Host Binary Server program. When a DTS initiates the connection to the binary port, it can send data to the host in packet form. The port and IP address are configurable. When UDP protocol is used, no connection is required.

## DTS Commands

The DTS software runs as embedded software on the DTS 3250 temperature scanner hardware. It performs the following general tasks:

- 1) Read and filter the raw A/D counts that represent temperature.
- 2) Convert the A/D counts to user chosen temperature units.
- 3) Receive and execute commands from the Ethernet Link.
- 4) Allow the configuration to be saved through power down.
- 5) Output converted data, status, setup and calibration data over the Ethernet Link.
- 6) Set the DTS Physical Ethernet Address(MAC Address).
- 7) Protocol to be TCP/IP.
- 8) Support the user in troubleshooting the DTS hardware and system.

When operating in the ASCII mode or UDP, the DTS is the client. In Binary or TCP mode, the DTS is the Host.

When a DTS module is in a "NOT READY" mode, all commands are disabled except STATUS and STOP.

TCP/IP does not guarantee that packet boundaries will be maintained between a Host and a DTS module. Therefore, **ALL** commands from a Host **MUST** be terminated properly with one of four options. The DTS will detect and adjust to the termination option being used by a Host.

The four options are:

- CR (ASCII 13)
- LF (ASCII 10)
- LF-CR (ASCII 10 - ASCII 13)
- CR-LF (ASCII 13 - ASCII 10)

The current DTS RS232 interface is designed for initial boot configuration only.

# Command List

|                |  |
|----------------|--|
| COMMAND        | <b>A/D CALIBRATION</b>   |
| COMMAND SYNTAX | <b>ADCAL</b>   |
| ARGUMENTS      | None   |
| DESCRIPTION    | Commands the DTS to calibrate the A/D converters. The A/D converters are calibrated automatically at power up and whenever the period configuration variable is set. It is possible for errors in the conversion if the temperature of the DTS has changed significantly since power up. In this case, the A/D converters can be calibrated by issuing this command. |
| RETURNS        | <code>&lt;n/&gt;</code><br><code>&lt;n/&gt;</code> - end of line.  |
| EXAMPLE        | To calibrate the A/D converters after several hours of operation, the following command would be issued:<br><code>ADCAL &lt;CR&gt;</code><br>The A/D converters will be calibrated. The time depends upon the setting of CALAVG. If CALAVG is set to 1, the time will be several seconds. If CALAVG is set to 64 this can require several minutes.                   |
| NOTE           | It is recommended that a user check for A/D errors after the execution of this command. If an A/D times out or does not respond correctly, it will be disabled in software and an error will be logged. The error log is the only indication that this has occurred.   |
| COMMAND        | <b>AUTOSTATUS</b>  |
| COMMAND SYNTAX | <b>AUTOSTATUS &lt;enable&gt;</b>   |
| ARGUMENTS      | <b>AS &lt;enable&gt;</b> (Optional)  |
| DESCRIPTION    | Enable - 0 or 1<br>If autostatus enable is set to 1, the DTS will automatically output the status of the DTS whenever the status changes. When set to 0, status can only be determined by issuing a STATUS command. The condition at power up and after a reboot is AUTOSTATUS disabled.   |
| RETURNS        | <code>&lt;n/&gt;</code><br><code>&lt;n/&gt;</code> - end of line.  |
| EXAMPLE        | To enable automatic output of the DTS status, the following command would be issued:<br><code>AUTOSTATUS 1</code><br>To disable automatic output of the DTS status, the following command would be issued:<br><code>AUTOSTATUS 0</code>  |
| NOTE           | AUTOTATUS was not set up as a configuration variable that could be saved to prevent conditions where the DTS would be talking on a network when it was not expected to be talking.<br>An optional syntax is available. Either syntax will enable or disable Autostatus.  |

|                |  |
|----------------|--|
| COMMAND        | <b>CLEAR</b>   |
| COMMAND SYNTAX | <b>CLEAR</b>   |
| ARGUMENTS      | None   |
| DESCRIPTION    | Commands the DTS to clear any errors that have occurred. The errors are sent to the client in an ASCII Packet. ASCII Packets are described in a subsequent sections. |
| RETURNS        | <nl><br><nl> - end of line.  |
| EXAMPLE        | To clear any errors listed in the ERROR Buffer, the following command would be issued:<br>CLEAR <CR><br><br>The ERROR buffer will be cleared                         |

|                |   |
|----------------|---|
| COMMAND        | <b>CLOSE HOST BINARY SERVER CONNECTION</b>  |
| COMMAND SYNTAX | <b>CLOBIN</b>   |
| ARGUMENTS      | None  |
| DESCRIPTION    | Commands the DTS to close the connection to the Host Binary Server. This command will only be accepted by the DTS when the DTS is in the <b>READY</b> mode. |
| RETURNS        | <nl><br><nl> - end of line.   |
| EXAMPLE        | To close the connection to the Host Binary Server, the following command would be issued:<br>CLOBIN <CR><br><br>The connection will be terminated           |

|                |   |
|----------------|---|
| COMMAND        | <b>CONNECT TO HOST BINARY SERVER</b>  |
| COMMAND SYNTAX | <b>CONBIN</b>   |
| ARGUMENTS      | None  |
| DESCRIPTION    | Commands the DTS to connect to the Host Binary Server configured through the HOST configuration variable. If the DTS is in the UDP mode or if a TCP connection is already established, an Error will be generated. This command will only be accepted when the DTS is in the <b>READY</b> mode.   |
| RETURNS        | <nl><br><nl> - end of line.   |
| EXAMPLE 1      | A DTS is not connected to a server, is not in the UDP mode and is in the READY mode. A CONBIN command is generated to open a connection to the Host. The following command would be issued:<br>CONBIN <CR><br>The DTS will be connected to the Host.  |
| EXAMPLE 2      | A DTS is not connected to a server, is in the UDP mode and is in the READY mode. A CONBIN command is generated to open a connection to the Host. The following command would be issued:<br>CONBIN <CR><br>The DTS will not connect to the Host and an Error will be generated.  |
| EXAMPLE 3      | A DTS is not connected to a server, is in the UDP mode and is in the SCAN mode. A CONBIN command is generated to open a connection to the Host. The following command would be issued:<br>CONBIN <CR><br>The DTS will not connect to the Host and an Error will be generated.   |
| COMMAND        | <b>CORRECT RTD VOLTAGE TABLES</b>   |
| COMMAND SYNTAX | <b>ARPC &lt;Reference Temperature&gt; &lt;board&gt;</b>   |
| ARGUMENTS      | Reference Temperature -           The indicated temperature of the standard RTD.<br>Board                   -           The board set to be corrected. ( 1 to 4)  |
| DESCRIPTION    | This command calculates the voltage difference, in microvolts between the Reference RTD value and the voltage value of the RTDs in the board set entered in the command. The calculated value is stored in the ARPC variable for that board set. If ARPCON is set to 1, this value will be used to correct the board set RTD voltages before the Calander Van-Duse correction is applied to the RTDs. The ARPC command may only be entered for the number of board sets installed. Board values outside the allowed number will result in an error. |
| EXAMPLES       | To calculate a correction for board 1 in a 16 channel module when the reference RTD is 29.95 degrees C:<br>Type:  ARPC 29.95 1<Enter>   |
| NOTE           | This command will update the ARPC variables, but the data will not be saved until a SAVE command is issued. Scanivalve Corp recommends that a user verify that the correction generated is valid before issuing a SAVE command. The values stored in the ARPC variables will be lost if power is cycled before a SAVE command is executed.  |
| COMMAND        | <b>ENTER CHANNEL CALIBRATION SETPOINTS</b>  |

COMMAND SYNTAX  
ARGUMENTS

**PT <index> <volts> [channel]**

Index - The setpoint number, 0 to 7 for setpoints 1 to 8.  
Volts- The applied voltage.  
Channel - Optional, If a channel is not specified, the setpoint voltage will be applied to all channels.

DESCRIPTION

This command syntax is only used when NUMTEMPS is set to 0. This command enters the voltage correction to be applied at a given setpoint for one or more channels. The values for the setpoints do not have specific limitations.

EXAMPLES

To enter a value for setpoint 1 for all channels:  
Type: PT 1 1.256<Enter>  
To enter a value for setpoint 2 for channel 9:  
Type: PT 2 1.744 9<Enter>

NOTE

This command syntax is used only if NUMTEMPS is set to 0. The value of NUMTEMPS **MUST NOT** be modified by an end user without detailed and specific training from Scanivalve Corp. If the value of NUMTEMPS is modified after the unit has been calibrated, **ALL** current calibration coefficients will be **LOST**.

COMMAND  
COMMAND SYNTAX  
ARGUMENTS

**ENTER CHANNEL CALIBRATION SETPOINTS**

**PT <T || R> <chan/board> <temp ndx> <temp> <pt ndx> <act volts>**

T || R - T/C or RTD  
Chan/board - A single channel, 1 to 64 for T/C or 1 to 4 for RTD  
A range of channels, start chan..end chan  
Temp ndx - The temperature index, from 1 to NUMTEMPS.  
Temp - The temperature of this point.  
Pt ndx - The index of this point from 1 to NUMPTS.  
Act volts - The actual applied volts.

DESCRIPTION

This command syntax is only used when NUMTEMPS is set to 1 or greater. This command enters the voltage correction at the temperature entered for a given setpoint for one or more T/C or RTD channels. The values for the setpoints do not have specific limitations.

EXAMPLES

To enter a value for Temperature channels 1 through 16 at 23 degrees C if NUMTEMPS is set to 5 and NUMPTS is set to 8:  
Type: PT T 1 1..16 5 23 3 .256<Enter>

NOTE

This command syntax is used only if NUMTEMPS is set to 1 or greater. The value of NUMTEMPS **MUST NOT** be modified by an end user without detailed and specific training from Scanivalve Corp. If the value of NUMTEMPS is modified after the unit has been calibrated, **ALL** current calibration coefficients will be **LOST**.

COMMAND

**ENTER RTD CALIBRATION SETPOINTS**

COMMAND SYNTAX  
ARGUMENTS

**RPC <index> <volts> <board>**

Index - The setpoint number, 0 to 7 for setpoints 1 to 8.  
Volts - The applied voltage.  
Board - The A/D board, 1, 2, 3 or 4

DESCRIPTION

This command enters the voltage correction to be applied at a given setpoint for the RTD's. The values for the setpoints must be between 0.095 Vdc and 0.131 Vdc which represents temperatures from -13 ° C to 80 ° C . The voltage for board 1 must be inserted in the RTD1 input. The voltage for board 2 must be inserted in the RTD3 input. The voltage for board 3 must be inserted in the RTD5 input. The voltage for board 4 must be inserted in the RTD7 input.

EXAMPLES

To enter a value for setpoint 1 for the RTD's on board 2:  
Type: RPC 1 0.095 2<Enter>

To enter a value for setpoint 2 for the RTD's on board 1:  
Type: RPC 2 0.998 1<Enter>

COMMAND  
COMMAND SYNTAX  
ARGUMENTS  
DESCRIPTION

**ERROR**

**ERROR**

None

Lists the errors that are stored and listed after a CLEAR. Only the first 72 errors will be listed. If more than 72 errors have occurred, the message: "ERROR: Max Errors exceeded "will appear at the end of the list. The return format is:

ERROR: error

EXAMPLE

To read the contents of the Error Buffer:  
Type: ERROR<Enter>

The DTS will return the last 72 errors in the format::

If no errors have been logged, the DTS will return:  
ERROR: No errors

COMMAND  
COMMAND SYNTAX  
ARGUMENTS  
DESCRIPTION

**FILL**

**FILL**

None

Activates the setpoint data. If Setpoints are configured, a FILL will be executed automatically at power-up. A FILL can be executed manually at any time.

EXAMPLE

To execute a FILL and activate the setpoints:  
Type: FILL<CR>

COMMAND  
COMMAND SYNTAX  
ARGUMENTS

DESCRIPTION

RETURNS

### HOST BINARY SERVER COMMAND

#### HOST <command>

Command - An ASCII command that would be recognized by the Host Binary Server.

This command will pass a Host Binary Server command through the DTS to the Host Binary Server

<nl>

<nl> - end of line.

COMMAND  
COMMAND SYNTAX  
ARGUMENTS

DESCRIPTION

### ICE POINT OFFSET ADJUSTMENT

#### IPO <start channel> <end channel>

<start channel> - the first channel to be adjusted.

<end channel> - the last channel to be adjusted

Commands the DTS to calculate and adjust the offset settings for the channels specified. If an end channel is not specified, only the start channel will be modified. This command assumes that 0 degrees C is applied to the specified channels. A SAVE command must be issued when this command is completed to make the changes permanent

COMMAND  
COMMAND SYNTAX  
ARGUMENTS  
DESCRIPTION  
EXAMPLE

### LIST CALIBRATION

#### LIST C

None

Lists the calibration configuration variables.

To view the calibration configuration variable settings:

Type: LIST C<CR>

The DTS will return the calibration configuration variable settings. They could appear as follows.

SET NUMCOEF 3

SET NUMPTS 8

SET CALAVG 4



COMMAND  
COMMAND SYNTAX  
ARGUMENTS

DESCRIPTION

EXAMPLE

NOTE1

NOTE2

### LIST CHANNEL CORRECTION SETPOINTS

#### LIST P <channel>

Channel - is any valid channel number from 0 to 16, 32 or 64 depending on the module type.

Lists the calibration setpoints for the channel listed. If channel 0 is specified, the setpoints for all channels will be listed.

To view the calibration setpoints for channel 1:

Type: LIST P 1<CR>

The DTS returns:

```
SET PT 1 0 -0.010000 -275283
SET PT 1 1 0.000000 1288
SET PT 1 2 0.012000 333064
SET PT 1 3 0.024000 664759
SET PT 1 4 0.036000 996312
SET PT 1 5 0.048000 1327909
SET PT 1 6 0.060000 1659352
SET PT 1 7 0.070000 1935411
```

The values shown here are values a typical one module. The actual calibration setpoints in a different module may be different.

This syntax is used only when NUMTEMPS is set to 0.

COMMAND  
COMMAND SYNTAX  
ARGUMENTS

DESCRIPTION

EXAMPLE

NOTE1

NOTE2

### LIST CHANNEL CORRECTION SETPOINTS

#### LIST P [<T || R> <chan/board> <temp>]

T || R - T/C or RTD

Chan/board - A single channel, 1 to 64 for T/C or 1 to 4 for RTD  
A range of channels, start chan..end chan.

Temp - a single temp,  
A range of temperature indexes, start temp..end temp.

Lists the calibration setpoints with the following conditions:

1. If no variables are specified, the setpoints for all T/C and RTD channels will be listed.
2. If only T or R is specified, all T/C or all RTD channels will be listed.
3. If T or R and chan/board are specified, a single channel or range of channels for T/Cs or RTDs will be specified.
4. If T or R and chan/board and temp are specified, a single channel or range of channels, and a single temperature or range of temperatures

To view the calibration setpoints for RTD channel 1 at 23 degrees C:

Type: LIST P R 1 23<CR>

The DTS returns:

```
SET PT 1 0 -0.010000 -275283
```

The values shown here are values a typical one module. The actual calibration setpoints in a different module may be different.

This syntax is used only when NUMTEMPS is set to 1 or greater.

COMMAND  
COMMAND SYNTAX  
ARGUMENTS

DESCRIPTION

EXAMPLE

## **LIST CHANNEL DEFINITIONS**

### **LIST DEF <channel>**

Channel - is a valid channel number 1 through 64, depending on the module type.

Lists the channel definitions for the specified channel. Only one channel may be specified at a time because of the size of the returned ASCII string. The definition for each channel may be 2048 bytes

To view the calibration setpoints for channel 1:

Type: LIST DEF 1<CR>

The DTS returns:

DEF 1 < ASCII String up to 2048 bytes>

COMMAND  
COMMAND SYNTAX  
ARGUMENTS

DESCRIPTION

EXAMPLE

## **LIST CONFIGURATION VARIABLES**

### **LIST A**

None

Lists all of the Configuration Variables.

To view or log the configuration variables:

Type: LIST A<CR>

The DTS will return all configuration variables

COMMAND  
COMMAND SYNTAX  
ARGUMENTS  
DESCRIPTION

EXAMPLE

## **LIST GAIN**

### **LIST G**

None.

Lists the thermocouple gain correction assigned to the channel listed.

To view the thermocouple gain settings in a 16 channel module:

Type: LIST G <CR>

The DTS will return all of the thermocouple gain settings. They could appear as follows.

```
SET GAIN 1 1.11
SET GAIN 2 1.01
SET GAIN 3 0.98
SET GAIN 4 1.12
SET GAIN 5 1.01
SET GAIN 6 1.15
SET GAIN 7 1.00
SET GAIN 8 1.11
SET GAIN 9 0.99
SET GAIN 10 0.98
SET GAIN 11 1.10
SET GAIN 12 1.01
SET GAIN 13 1.06
SET GAIN 14 1.00
SET GAIN 15 0.99
SET GAIN 16 1.10
```

COMMAND  
COMMAND SYNTAX  
ARGUMENTS  
DESCRIPTION  
EXAMPLE

## **LIST IDENTIFICATION**

### **LIST I**

None

Lists the IDENTIFICATION configuration variables.  
To verify the general module configuration settings:

Type: LIST I<CR>

The DTS will return:

```
SET ECHO 0
SET AUTOCON 0
SET HOST 0 0 T
SET HOSTCMD 0
SET TCMAXSLEW 50000
SET RTDMAXSLEW 64000
SET TITLE1 DTS3250/64Tx
SET TITLE2 Version 4.12
SET PORT 23
```

NOTE

A user must be very careful when modifying one of these variables. An incorrect value in one of these variables could have a detrimental affect on the operation of the module.

COMMAND  
COMMAND SYNTAX  
ARGUMENTS  
DESCRIPTION  
EXAMPLE

## **LIST LABELS**

### **LIST LA**

None

Lists the channel labels.

To view the channel labels:

Type: LIST LA<CR>

The DTS will return:

```
SET LABEL 1 T/C1
SET LABEL 2 T/C2
SET LABEL 3 T/C3
SET LABEL 4 T/C4
SET LABEL 5 T/C5
SET LABEL 6 T/C6
SET LABEL 7 T/C7
SET LABEL 8 T/C8
SET LABEL 9 T/C9
SET LABEL 10 T/C10
SET LABEL 11 T/C11
SET LABEL 12 T/C12
SET LABEL 13 T/C13
SET LABEL 14 T/C14
SET LABEL 15 T/C15
SET LABEL 16 T/C16
```

COMMAND  
COMMAND SYNTAX  
ARGUMENTS  
DESCRIPTION

## LIST LIMITS

### LIST LI

None

Lists the channel high and low limits for alarms

### EXAMPLE

To verify the channel limit settings for a 16 channel module:

Type: LIST LI<CR>

The DTS will return:

```
SET LIMIT 1 1 500.00 -50.00
SET LIMIT 2 1 500.00 -50.00
SET LIMIT 3 1 500.00 -50.00
SET LIMIT 4 1 500.00 -50.00
SET LIMIT 5 1 500.00 -50.00
SET LIMIT 6 1 500.00 -50.00
SET LIMIT 7 1 500.00 -50.00
SET LIMIT 8 1 500.00 -50.00
SET LIMIT 9 1 500.00 -50.00
SET LIMIT 10 1 500.00 -50.00
SET LIMIT 11 1 500.00 -50.00
SET LIMIT 12 1 500.00 -50.00
SET LIMIT 13 1 500.00 -50.00
SET LIMIT 14 1 500.00 -50.00
SET LIMIT 15 1 500.00 -50.00
SET LIMIT 16 1 500.00 -50.00
```

### NOTE

For more information, refer to the SET LIMIT configuration variable in the LI Group.

COMMAND  
COMMAND SYNTAX  
ARGUMENTS  
DESCRIPTION

## LIST NETWORK IDENTIFICATION

### LIST ID

None

Lists the MODULE NETWORK IDENTIFICATION configuration variables to support the Network ID command.

### EXAMPLE

To verify the Network Identification configuration settings:

Type: LIST ID<CR>

The DTS will return:

```
SET IPADDR <IP Address>
SET MODEL <Model/channels>
SET SERNUM <Serial number>
SET VER <Firmware Version>
```

COMMAND  
COMMAND SYNTAX  
ARGUMENTS  
DESCRIPTION

### LIST OFFSET

#### LIST O

None

Lists the thermocouple offset correction assigned to the channel specified. If channel 0 is specified, all 16 offsets will be returned. The OFFSET values are A/D counts.

EXAMPLE

To view all of the thermocouple offset settings in a 16 channel module:

Type: LIST O <CR>

The DTS will return the thermocouple offset settings. They could appear as follows.

```
SET OFFSET 1 120
SET OFFSET 2 77
SET OFFSET 3 78
SET OFFSET 4 112
SET OFFSET 5 101
SET OFFSET 6 115
SET OFFSET 7 60
SET OFFSET 8 11
SET OFFSET 9 99
SET OFFSET 10 101
SET OFFSET 11 44
SET OFFSET 12 57
SET OFFSET 13 16
SET OFFSET 14 124
SET OFFSET 15 81
SET OFFSET 16 25
```

COMMAND  
COMMAND SYNTAX  
ARGUMENTS  
DESCRIPTION

### LIST RTD CORRECTION VALUES

#### LIST RPC <board>

Board - The A/D board 1, 2, 3 or 4

Lists the RTD correction values

EXAMPLE

This command is used to verify the RTD correction values for each A/D board. To view the RTD correction values for A/D board 3:

Type: LIST RPC 3<CR>

The DTS will return:

```
SET RPC 3 0 0.095000 1271278
SET RPC 3 1 0.100000 1338897
SET RPC 3 2 0.105000 1406643
SET RPC 3 3 0.110000 1474311
SET RPC 3 4 0.115000 1542011
SET RPC 3 5 0.120000 1609718
SET RPC 3 6 0.125000 1677418
SET RPC 3 7 0.131000 1758718
```

**NOTE:**

The values shown here are values for a standard module. The actual calibration setpoints for another module may be different.

COMMAND  
COMMAND SYNTAX  
ARGUMENTS  
DESCRIPTION

**LIST RTD CONVERSION VALUES**  
**LIST RTDP**

None

Lists the RTD conversion values for all RTD channels. There will be two values for a 16 channel module, 4 values for a 32 channel module and 8 values for a 64 channel module

EXAMPLE

This command is used to verify the RTD correction values of the DTS.

Type: LIST RTD<CR>

A 64 channel DTS will return:

SET RTD 1 100.0000 3.908e-03 -5.775e-07

SET RTD 2 100.0000 3.908e-03 -5.775e-07

SET RTD 3 100.0000 3.908e-03 -5.775e-07

SET RTD 4 100.0000 3.908e-03 -5.775e-07

SET RTD 5 100.0000 3.908e-03 -5.775e-07

SET RTD 6 100.0000 3.908e-03 -5.775e-07

SET RTD 7 100.0000 3.908e-03 -5.775e-07

SET RTD 8 100.0000 3.908e-03 -5.775e-07

NOTE

The values shown here are values for an ideal module. The actual calibration setpoints may be different.

COMMAND  
COMMAND SYNTAX  
ARGUMENTS  
DESCRIPTION

**LIST RTD CURRENT CONVERSION VALUES**  
**LIST RTDX**

None

Lists the RTD current conversion values for all RTD channels. There will be two values for a 16 channel module, 4 values for a 32 channel module and 8 values for a 64 channel module

EXAMPLE

This command is used to verify the RTD current correction values of the DTS. This variable corrects for errors in the RTD excitation circuit.

Type: LIST RTDX<CR>

A 64 channel DTS will return:

SET RTDX1 1.0000000

SET RTDX2 1.0000000

SET RTDX3 1.0000000

SET RTDX4 1.0000000

SET RTDX5 1.0000000

SET RTDX6 1.0000000

SET RTDX7 1.0000000

SET RTDX8 1.0000000

NOTE

The values shown here are values for an ideal RTD excitation circuit. The actual values may be different.

COMMAND  
COMMAND SYNTAX  
ARGUMENTS  
DESCRIPTION

**LIST SCAN**  
**LIST S**  
None  
Lists the SCAN configuration variables

EXAMPLE

This command is used to verify the general scan settings of the DTS

Type: LIST s<CR>

The DTS will return:

SET PERIOD 6250  
SET AVG 1  
SET FPS 0  
SET XSCANTRIG 0  
SET FORMAT 0  
SET TIME 2  
SET BIN 0  
SET QPKTS 0  
SET UNITS C  
SET RANGEV -9999.999 9999.999  
SET RANGET -9999.99 9999.99  
SET RATE <value>

This value will be a function of Period, Average and the number of channels.

COMMAND  
COMMAND SYNTAX  
ARGUMENTS  
DESCRIPTION

**LIST TYPE**  
**LIST T**  
None

EXAMPLE

Lists the thermocouple TYPE assigned to the channel specified. If channel 0 is specified, all channels will be listed.

To view the thermocouple type settings:

Type: LIST T <CR>

The DTS will return the thermocouple type settings. They could appear as follows in a 16 channel DTS

SET TYPE 1 K 1  
SET TYPE 2 K 1  
SET TYPE 3 K 1  
SET TYPE 4 N 1  
SET TYPE 5 N 1  
SET TYPE 6 E 0  
SET TYPE 7 R 0  
SET TYPE 8 R 0  
SET TYPE 9 S 1  
SET TYPE 10 S 1  
SET TYPE 11 T 1  
SET TYPE 12 T 1  
SET TYPE 13 E 1  
SET TYPE 14 J 1  
SET TYPE 15 K 1  
SET TYPE 16 E 1

COMMAND  
COMMAND SYNTAX  
ARGUMENTS  
DESCRIPTION

## LIST UTR CALIBRATION VARIABLES

### LIST U

None

Lists the RTD calibration configuration variables

#### EXAMPLE

This command is used to verify the calibration configuration settings of the DTS.

Type: LIST U<CR>

The DTS will return:

SET RNUMCOEF 3

SET RNUMPTS 8

SET MAXDELTA 1.000000

SET ARPCON 0

SET ARPC x 0.000      Where x is the board number

#### NOTES:

The values shown here are values for a standard module. The actual calibration setpoints for a different module may be different.

A 16 channel module will only display ARPC 1, A 32 channel module will display ARPC 1 and ARPC 2, A 64 channel module will display ARPC 1, ARPC 2, ARPC 3, and ARPC 4

COMMAND  
COMMAND SYNTAX  
ARGUMENTS  
DESCRIPTION

## OPEN THERMOCOUPLE TEST

### OTC

None

Commands the DTS to test for open thermocouples. The command causes a small current to be applied to each thermocouple. If a thermocouple is found to be open, an error is logged and bit 12 in the channel status element of the data packet is set to a 1 (1000Hex). Also, the channel status code for an open channel will be 2000 if scanning with FORMAT set to 0. This command is NOT performed automatically at power up.

#### RETURNS

<n/ >

<n/ > - end of line.

#### EXAMPLE

To test for open thermocouples, the following command would be issued:

OTC<CR>

COMMAND  
COMMAND SYNTAX  
ARGUMENTS  
DESCRIPTION

## REBOOT

### REBOOT

None

Commands the DTS to reboot. Any coefficients and configuration variables that have not been saved will be reset to the last saved values.

#### RETURNS

<n/ >

<n/ > - End of line.

#### EXAMPLE

To reboot from the network,

Type: REBOOT<CR>



COMMAND  
COMMAND SYNTAX  
ARGUMENTS  
DESCRIPTION

**SAVE**

**SAVE**

None

Commands the DTS to save the RAM image of Non Volatile Memory(NVM). Any change to a configuration variable must be followed by a SAVE command if the change is to be permanent.

RETURNS

<nl>

<nl> - End of line.

EXAMPLE

To save the current configuration variable settings and conversion coefficients,

Type: SAVE<CR>

COMMAND  
COMMAND SYNTAX  
ARGUMENTS  
RETURNS

**SCAN**

**SCAN**

None

Scan data formatted by the setting of EU, BIN, and FORMAT. Refer to the examples for more information. When FORMAT is set to 0, a channel status code will be returned with the data for each channel. If multiple errors exist the code with the highest priority will be the only code displayed

| Status Code | Description             | Priority |
|-------------|-------------------------|----------|
| 1000        | Channel A/D is disabled | 1        |
| 2000        | Channel T/C is open     | 2        |
| 3000        | Channel is over range   | 3        |
| 4000        | Channel is under range  | 4        |
| 5000        | Channel is over limit   | 5        |
| 6000        | Channel is under limit  | 6        |

DESCRIPTION

Commands the DTS to scan the pressure sensors and send Scan packets to the client. Data are returned immediately if XSCANTRIG is set to 0. If XSCANTRIG is set to 1, data will be returned after a hardware trigger, or a software trigger. For more information on software triggers, refer to the SCAN TRIGGER command. For Hardware trigger requirements, refer to the Trigger Requirements section.

EXAMPLE 1

EU = 1

BIN = 0

FORMAT= 0.

Data are scrolled and will be displayed as follows:

Frame # <number>

Time <time> <µs or ms>

Rtd1 <temp>

“ ”

RtdMax <temp>

Units <unit>

<chan 1> <temp eu> <channel status code>

“ ”

“ ”

<chan Max> <temp eu> <channel status code>

EXAMPLE 2

```

EU = 0
BIN = 0
FORMAT= 0
Data are scrolled and will be displayed as follows:
Frame # <number>
Time <time> <µs or ms>
Rtd1  <temp counts>
      "      "
      "      "
RtdMax <temp counts>
Units  <unit>
<chan 1> <temp counts> <channel status code>
      "      "
      "      "
<chan Max> <temp counts> <channel status code>

```

EXAMPLE 3

```

EU = 1
BIN = 0
FORMAT = 1
Data are scrolled in place and will be displayed as follows:
Frame = <number> Time = <time> <µs or ms> Units = <unit>
RTD1 <temp> ..... RTDMax <temp>
<chan> <temp eu> <chan><temp eu> <chan> <temp eu> <chan> <temp eu>
<chan> <temp eu> <chan><temp eu> <chan> <temp eu> <chan> <temp eu>
<chan> <temp eu> <chan><temp eu> <chan> <temp eu> <chan> <temp eu>
      "      "      "      "      "      "      "      "
<chan> <temp eu> <chan><temp eu> <chan> <temp eu> <chan> <temp eu>

```

EXAMPLE 4

```

EU = 0
BIN = 0
FORMAT = 1
Data are scrolled and will be displayed as follows:
Frame = <number> Time = <time> <µs or ms> Units = <unit>
RTD1 <counts>.....RTDMax <counts>
<chan> <temp cts> <chan><temp cts> <chan> <temp cts> <chan> <temp cts>
<chan> <temp cts> <chan><temp cts> <chan> <temp cts> <chan> <temp cts>
<chan> <temp cts> <chan><temp cts> <chan> <temp cts> <chan> <temp cts>
      "      "      "      "      "      "      "      "
<chan> <temp cts> <chan><temp cts> <chan> <temp cts> <chan> <temp cts>

```

COMMAND  
COMMAND SYNTAX  
ARGUMENTS  
DESCRIPTION

## SCAN TRIGGER

### TRIG

None

This command acts as a software trigger to the DTS. When XSCANTRIG is set to 1, an averaged frame of data will be output when the DTS receives the TRIG command or a <TAB> character code (9 HEX or Control I). This will continue until a STOP command is issued or the Frames per Scan variable is met. The data format will depend upon the setting of EU, BIN and FORMAT.

### EXAMPLE 1

A scan command is executed with EU set to 1, BIN set to 0, XSCANTRIG set to 1, and FORMAT set to 0. The DTS will wait for a Hardware trigger, the TRIG command or a <TAB> character (9 HEX or Control I). When one of the Data are scrolled and will be displayed as follows:

```
Frame # <number>  
Time <time> <µs or ms>  
<chan> <temp eu>  
  "      "  
  "      "  
<chan> <temp eu>
```

For information on other formats, refer to the SCAN command .

COMMAND  
COMMAND SYNTAX  
ARGUMENTS  
DESCRIPTION

## SET

### SET <name> <value>

<name> - the Configuration Variable to be set or modified.

<value> - the value of that Configuration Variable

Commands the DTS to set one of the many Configuration Variables. Configuration Variables are described in a subsequent section.

### NOTE

Listing the Configuration Variables with the LIST command outputs the data in the format required by the SET command. This enables the user to upload data from a file that has been created by a LIST download.

COMMAND  
COMMAND SYNTAX  
ARGUMENTS  
DESCRIPTION

**STATUS**

**STATUS**

None

Commands the DTS to send a Status Packet to the client. The Status Packet is described in a subsequent section.

The STATUS command may be entered at any time. This is one of the commands that will not generate an error if entered while the DTS is not READY. The DSM could return one of the following status descriptions:

|         |   |
|---------|---|
| ADCAL   | The DTS is calibrating the A/D converters           |
| CAL     | The DTS is executing a PT or RPT command            |
| INVALID | The DTS is in an INVALID operating mode.            |
| LIST    | The DTS is outputting a configuration variable LIST |
| OTC     | The DTS is testing for open thermocouples           |
| PERIOD  | The DTS is executing a SET PERIOD command           |
| READY   | The DTS is operating and ready to accept a command. |
| SAVE    | The DTS is SAVING a configuration                   |
| SCAN    | The DTS is in the SCAN mode.                        |
| TYPE    | The DTS is setting the thermocouple type            |
| UPLOAD  | The DTS is UPLOADING a file.                        |

EXAMPLES

If the STATUS command is entered while the DTS is on, but inactive, the DSM will return:

Status: READY

If the STATUS command is entered while the DSM is executing a SAVE command, the DSM will return:

Status: SAVE

COMMAND  
COMMAND SYNTAX  
ARGUMENTS  
DESCRIPTION  
RETURNS

**STOP**

**STOP**

None

Commands the DTS to abort the current operation.

<n/ >

<n/ > - end of line.

EXAMPLE

To abort any function or operation:

Type: STOP<CR>

COMMAND  
COMMAND SYNTAX  
ARGUMENTS

DESCRIPTION

RETURNS

EXAMPLE

NOTE

COMMAND  
COMMAND SYNTAX  
ARGUMENTS  
DESCRIPTION  
RETURNS

EXAMPLE

## UPLOAD

**UPLOAD <S or C><filepath\filename>**

S System file to be uploaded

C Configuration file to be uploaded

Uploads the specified file to the DTS module. The DTS interprets the type of file based on the file type argument.

<nl>

<nl> - end of line.

To upload the configuration variable file cv.cfg, located in the DTS files subdirectory on drive c: of the host computer:

Type: UPLOAD C c:\DTSfiles\cv.cfg

This file will be downloaded from the machine defined by the configuration port settings. The term "host" might be more accurately described as an "FTP Server". This could be the same computer as the host or a different computer somewhere on a network. The relevant settings are:

Host Name

Host INET

User

FTP Password

S or C must be uppercase

Refer to the DTS3200 Boot Parameter Modification and DTS Operating System Upload Procedures for more information.

## VERSION

**VER**

None

Outputs the current software version number.

DTS Scanivalve © 2004 Ver x.xx y channels H/W ver z

x.xx is the software version number.

y is the number of channels ( 16, 32 or 64)

z is the hardware version number

To read the current software version in a 64 channel module:

Type: VER<CR>

The DTS returns:

Version: DTS Scanivalve © 2008 Ver 4.14 64 channels H/W Ver 9

## Configuration Variables

Configuration Variables control the way the DTS functions. The Variables are assigned to one of several groups: SCAN(S), IDENTIFICATION(I), NETWORK IDENTIFICATION(ID), CHANNEL DEFINITION(DEF), CALIBRATION(C), CHANNEL CORRECTION(P), GAIN(G), OFFSET(O), LABELS(LA), LIMIT(LI), THERMOCOUPLE(T), RTD CORRECTION(RP), RTD CONVERSION(RTDP), and RTD CALIBRATION(U). Each variable is assigned a "data type" description.

### Scan Variables (Group S)

|               |  |
|---------------|--|
| VARIABLE      | <b>AVG &lt;value&gt;</b>   |
| VALID VALUES  | 1 to 240   |
| DEFAULT VALUE | 4  |
| DATA TYPE     | integer  |
| DESCRIPTION   | This sets the number of raw samples to acquire before producing a filtered output. |

|               |   |
|---------------|---|
| VARIABLE      | <b>BIN &lt;code&gt;</b>   |
| VALID VALUES  | 1 or 0  |
| DEFAULT VALUE | 0   |
| DATA TYPE     | integer   |
| DESCRIPTION   | Sets the format of the data packet output.<br>1 = Binary<br>0 = ASCII |

|               |  |
|---------------|--|
| VARIABLE      | <b>FORMAT &lt;code&gt;</b>   |
| VALID VALUES  | 0, or 1  |
| DEFAULT VALUE | 1  |
| DATA TYPE     | Integer  |
| DESCRIPTION   | Determines if data are to be scrolled on the display. ASCII Output only<br>0 - data are scrolled<br>1 - data are displayed in place, formatted for a VT100 terminal. |

|               |   |
|---------------|---|
| VARIABLE      | <b>FPS &lt;value&gt;</b>  |
| VALID VALUES  | 0 to 4294967295   |
| DEFAULT VALUE | 0   |
| DATA TYPE     | long integer  |
| DESCRIPTION   | Sets the number of averaged frames to send to the client. If a 0 is entered, the scan will continue until a STOP command is received. |

**VARIABLE** **PERIOD <value>**  
**VALID VALUES** 781 to 262144 µsec (64 Channel versions)  
781 to 524288 µsec (32 Channel Versions)  
781 to 1048576 µsec (16 Channel Versions)  
**DEFAULT VALUE** 7812  
**DATA TYPE** integer  
**DESCRIPTION** Sets the interval between channel samples.  
The maximum settings for each version represent the rate limits when AVG is set to 1. The rate limits are:

|             |   |               |
|-------------|---|---------------|
| 16 Channels | - | 40 Hz/Channel |
| 32 Channels | - | 20 Hz/Channel |
| 64 Channels | - | 10 Hz/Channel |

**NOTE** For 16 channel DTS modules running software version 2.04 and lower, periods faster than 6250 microseconds will result in a greater measurement uncertainty. Instrument accuracies listed in the specifications are based on periods of 6250 microseconds or slower.

**VARIABLE** **QPKTS <code>**  
**VALID VALUES** 0 or 1  
**DEFAULT VALUE** 1  
**DATA TYPE** integer  
**DESCRIPTION** This switch will control the action the DTS will take when the data buffer is full.

|     |   |
|-----|---|
| 0 - | frames will be discarded when the data buffer is full. The DTS will continue to scan.             |
| 1 - | no frames will be lost. The DTS will stop scanning and log an error if the data buffer is filled. |

**VARIABLE** **RANGET <low range temp value> <high range temp value>**  
**VALID VALUES** -9999.99 to 9999.99  
**DEFAULT VALUE** Low range temp value - -9999.99  
High range temp value - 9999.99  
**DATA TYPE** Integer  
**DESCRIPTION** Sets the output when units is set to a temperature and the high and/or low range limits are exceeded. When a channel exceeds the low limit, the data display will be setting of the low range value and the channel status code will indicate 4000. When the high limit is exceeded, the data display will be setting of the high range value and the channel status code will indicate 3000.

**VARIABLE** **RANGEV <low range volt value> <high range volt value>**  
**VALID VALUES** -9999.99 to 9999.99  
**DEFAULT VALUE** Low range volt value - -9999.99  
High range volt value - 9999.99  
**DATA TYPE** Integer  
**DESCRIPTION** Sets the output when units is set to volts and the high and/or low range limits are exceeded. When a channel exceeds the low limit, the data display will be setting of the low range value and the channel status code will indicate 4000. When the high limit is exceeded, the data display will be setting of the high range value and the channel status code will indicate 3000.

**VARIABLE** **RATE <value>**  
**VALID VALUES** .01 to 40  
**DEFAULT VALUE** Depends on the number of channels  
**DATA TYPE** Integer  
**DESCRIPTION** Calculates and modifies the setting of PERIOD to give a data output rate in samples per channel per second. The setting of AVG is included in the calculation but is not modified. Conversely, if PERIOD is modified, RATE will be updated to show the data rate based on that setting of PERIOD. If AVG is modified, the value of RATE will be updated to show the new data rate, but PERIOD will not be modified. If the calculated RATE exceeds the maximum allowed for a DTS Version, the rate will not change and an ERROR will be logged.  
The maximum rate for each version is:  
16 Channel - 40 Hz/Channel  
32 Channel - 20 Hz/Channel  
64 Channel - 10 Hz/Channel  
Rate is calculated by the formula:

$$DataRate = 1 + (Period \times NumberofChannels \times Average)$$

**VARIABLE** **TIME <code>**  
**VALID VALUES** 0, 1, or 2  
**DEFAULT VALUE** 0  
**DATA TYPE** Integer  
**DESCRIPTION** Determines the format of the Time Stamp.  
0 - No Time Stamp  
1 - Time stamp data are in microseconds  
2 - Time stamp data are in milliseconds

**VARIABLE** **UNITS <type>**  
**VALID VALUES** see list below  
**DEFAULT VALUE** 0  
**DATA TYPE** string  
**DESCRIPTION** Engineering Unit conversion type. This can be :  
A - Volts(Vdc) corrected by the RTD voltage  
C - degrees Celsius(°C)  
F - degrees Fahrenheit(°F),  
K - Kelvin( K)  
M - "Mixed," provides T/C readings in RAW mV and RTD readings in °C  
R - degrees Rankin( °R)  
V - Volts(Vdc) Raw uncorrected  
0 - Zero(Raw Counts)

**NOTE** The setting of UNITS affects the RTD temperature units.  
**ASCII Output (BIN = 0)**  
When UNITS is set to 0, the RTD temperature is in A/D counts.  
When UNITS is set to V or A, the RTD temperature is in millivolts.  
When UNITS is set to C, F, K, M or R, the RTD temperature is in degrees C.  
**Binary Output (BIN = 1)**  
When UNITS is set to 0, the RTD temperature is in A/D counts  
When UNITS is set to any other value, the RTD temperature is in degrees C.



|               |   |
|---------------|---|
| VARIABLE      | <b>XSCANTRIG &lt;code&gt;</b>   |
| VALID VALUES  | 0 to 15   |
| DEFAULT VALUE | 0   |
| DATA TYPE     | integer   |
| DESCRIPTION   | Sets the External Trigger as the Frame Trigger.<br>0 - The internal clock is the frame trigger<br>1 - The external trigger is the frame trigger<br>2 to 15 - The external trigger is the frame trigger. The external trigger timing will be divided by the number entered. If |

NOTES

If XSCANTRIG is set to 2, the triggering will be whatever the input rate is divided by 2. If the trigger rate is 10 Hz, the DTS will be triggered at a 5 Hz rate. If XSCANTRIG is set to 10 and the trigger rate is 10 Hz, the DTS will be triggered at a 1 Hz rate.

The External Trigger may be a hardware trigger or a Software Trigger. The hardware trigger is a pulse 9 to 15 volts at 6.5 ma. The software trigger is a Tab(Control I) character.

## Channel Correction Variables (Group P)

**NOTE** The PT variable on this page is used only if NUMTEMPS is set to 0. If NUMTEMPS is set to 1 or greater, the PT variable on the next page should be used. Please refer to the description of the NUMTEMPS variable in the Calibration Variable Group for more detailed information on THE NUMTEMPS variable.

|               |  |
|---------------|--|
| VARIABLE      | <b>PT &lt;channel&gt; &lt;index&gt; &lt;volts applied&gt; &lt;counts applied&gt;</b>   |
| VALID VALUES  | Channel - 0 to 16, 32 or 64<br>Index - 0 to 7<br>Volts Applied - any valid number<br>Counts Applied - any valid number   |
| DEFAULT VALUE | Channel - 0<br>Index - 0<br>Volts Applied - 0<br>Counts Applied - 0  |
| DATA TYPE     | Channel - Integer<br>Index - Integer<br>Volts Applied - float<br>Counts Applied - Integer  |
| DESCRIPTION   | This is the list of setpoints used to calibrate each channel. If zero (0) is entered, all channels will be returned.   |
| EXAMPLE       | The List P command is used to view these variables. The variables for each channel are set before the initial factory calibration. To list the values for channel 2, Type: |

LIST P 2<Enter>

The DTS will return:

```

SET PT 2 0 -0.010000 -276468
SET PT 2 1 0.000000 517
SET PT 2 2 0.012000 332795
SET PT 2 3 0.024000 664988
SET PT 2 4 0.036000 997039
SET PT 2 5 0.048000 1329141
SET PT 2 6 0.060000 1661087
SET PT 2 7 0.070000 1937569
    
```

**NOTE** The values shown here are values for a standard module. The actual calibration setpoints for a given module may be different.

**NOTE** The PT variable on this page is used only if NUMTEMPS is set to 1 or greater. If NUMTEMPS is set to 0, the PT variable on the previous page should be used. Please refer to the description of the NUMTEMPS variable in the Calibration Variable Group for more detailed information on THE NUMTEMPS variable.

|               |   |
|---------------|---|
| VARIABLE      | <b>PT &lt;T    R&gt; &lt;chan/board&gt; &lt;temp ndx&gt; &lt;temp&gt; &lt;pt ndx&gt; &lt;act volts&gt; &lt;counts&gt;</b>   |
| VALID VALUES  | T    R - T/C or RTD<br>Chan/board - A single channel, 1 to 64 for T/C or 1 to 4 for RTD<br>A range of channels, start chan..end chan<br>Temp ndx - The temperature index from 1 to NUMTEMPS<br>Pt ndx - The index of this point from 1 to NUMPTS<br>Act volts - The actual applied volts<br>Counts - The A/D counts at this point |
| DEFAULT VALUE | T    R - T<br>Chan/board - 1<br>Temp ndx - 5<br>Pt ndx - 5<br>Act volts - 0<br>Counts - 0   |
| DATA TYPE     | T    R - char<br>Chan/board - string<br>Temp ndx - integer<br>Pt ndx - integer<br>Act volts - float<br>Counts - integer   |
| DESCRIPTION   | This is the list of setpoints used to calibrate each channel.   |
| EXAMPLE       | The List P command is used to view these variables. The variables for each channel are set before the initial factory calibration. To list the values for RTD channel 2at 23 degrees C, Type:<br><br>LIST P R 2 23<Enter><br><br>The DTS will return:<br>SET PT R 2 3 23 3 .256 -276468   |
| NOTE          | The values shown here are values for a typical module. The actual calibration setpoints for a given module may be different.  |

## Identification Variables (Group I)

|               |   |
|---------------|---|
| VARIABLE      | <b>AUTOCON &lt;code&gt;</b>   |
| VALID VALUES  | 0 or 1  |
| DEFAULT VALUE | 0   |
| DATA TYPE     | integer   |
| DESCRIPTION   | Determines if the DTS will automatically convert to a binary receiver.<br>0 - the DTS will not automatically convert.<br>1 - the DTS will automatically convert.  |
|               |   |
| VARIABLE      | <b>ECHO &lt;code&gt;</b>  |
| VALID VALUES  | 0 or 1  |
| DEFAULT VALUE | 0   |
| DATA TYPE     | integer   |
| DESCRIPTION   | Determines if characters received from an ethernet host will be echoed back to the host.<br>0 - the DTS will not echo characters<br>1 - the DTS will echo characters back to the host.  |
|               |   |
| VARIABLE      | <b>HOST &lt;IP address&gt; &lt;port&gt; &lt;protocol&gt;</b>  |
| VALID VALUES  | IP Address - Any valid IP address<br>Port - Any valid Port<br>Protocol - T = TCP<br>U = UDP   |
| DEFAULT VALUE | IP Address - 0<br>Port - 0<br>Protocol - T  |
| DATA TYPE     | varies  |
| DESCRIPTION   | Sets the value of the IP address and port number for binary data for the host computer. If IP Address and Port are set to 0, Binary data are sent out over the TelNet Port. If a server address and port number are defined, Binary data are sent out over that port. |
|               |   |
| VARIABLE      | <b>HOSTCMD &lt;ASCII string&gt;</b>   |
| VALID VALUES  | any valid host command  |
| DEFAULT VALUE | 0   |
| DATA TYPE     | ASCII Strings   |
| DESCRIPTION   | Sends the ASCII command string contained in this variable to the host computer binary receiver.   |

**VARIABLE**  
**VALID VALUES**  
**DEFAULT VALUE**  
**DATA TYPE**  
**DESCRIPTION**

**PORT xxxx**  
Any valid port number other than 0  
23  
integer  
Sets the Ethernet port. The default value is 23 which is the TelNet port. A change to this variable does not take effect until the module has been rebooted.

**VARIABLE**  
**VALID VALUES**  
**DEFAULT VALUE**  
**DATA TYPE**  
**DESCRIPTION**

**RTD\_MAX\_SLEW <value>**  
0 to 32000  
0  
Integer  
This is the maximum allowable step change in counts per second for an RTD input. If the step change exceeds this value, the DTS will output the last value before the step. If the DTS stays out of range for 5 samples, then the new range will be considered to be the new value.

Zero (0) disables this function.

**NOTE**

This feature is only functional in hardware version 1. The hardware version is reported with the software version when a VER command is executed.

**VARIABLE**  
**VALID VALUES**  
**DEFAULT VALUE**  
**DATA TYPE**  
**DESCRIPTION**

**TC\_MAX\_SLEW <value>**  
0 to 3000000  
0  
Integer  
This is the maximum allowable step change in counts per second for a thermocouple input. If the step change exceeds this value, the DTS will output the last value before the step. If the DTS stays out of range for 5 samples, then the new range will be considered to be the new value.

Zero (0) disables this function.

**NOTE**

This feature is functional in all hardware versions. The hardware version is reported with the software version when a VER command is executed.

**VARIABLE**  
**VALID VALUES**  
**DEFAULT VALUE**  
**DATA TYPE**  
**DESCRIPTION**

**TITLE1 <title>**  
any valid ASCII string up to 255 characters  
Scanivalve DTS3250  
ASCII String  
Sets the value of Title number 1.

**VARIABLE**  
**VALID VALUES**  
**DEFAULT VALUE**  
**DATA TYPE**  
**DESCRIPTION**

**TITLE2 <title>**  
any valid ASCII string up to 255 characters  
The current software version.  
ASCII String  
Sets the value of Title number 2.

## Calibration Variables (Group C)

VARIABLE **CALAVG <value>**  
VALID VALUES 1 to 64  
DEFAULT VALUE 4  
DATA TYPE integer  
DESCRIPTION Determines how much averaging to perform during an A/D Calibration. This setting will have an effect on boot up time.

VARIABLE **NUMPTS <points>**  
VALID VALUES 1 to 8  
DEFAULT VALUE 8  
DATA TYPE integer  
DESCRIPTION Determines the number of setpoints in the channel correction list.

VARIABLE **NUMCOEF <coef>**  
VALID VALUES 1 to 3  
DEFAULT VALUE 3  
DATA TYPE integer  
DESCRIPTION Determines the number of calibration coefficients for the channel corrections.  
1 - Offset only  
2 -  $y = mx + b$  correction curve  
3 -  $y = ax^2 + bx + c$  correction curve

VARIABLE **NUMTEMPS <numtemps>**  
VALID VALUES 0 to 8  
DEFAULT VALUE 0  
DATA TYPE integer  
DESCRIPTION When set to 0, system acts like original. If set to 1 or greater, the module will use the following variables:  
PT Option  
And the following commands:  
PT Option  
List P Option

NOTE The value of NUMTEMPS **MUST NOT** be modified by an end user without detailed and specific training from Scanivalve Corp. If the value of NUMTEMPS is modified after the unit has been calibrated, **ALL** current calibration coefficients will be **LOST**.

## Network Identification Variables (Group ID)

|               |  |
|---------------|--|
| VARIABLE      | <b>IPADDRESS &lt;ip address&gt;</b>          |
| VALID VALUES  | Any Valid IP Address                         |
| DEFAULT VALUE | Current IP Address stored in Flash Memory    |
| DATA TYPE     | integer                                      |
| DESCRIPTION   | Stores the IP Address stored in Flash Memory |

|               |  |
|---------------|--|
| VARIABLE      | <b>MODEL &lt;model number/channels&gt;</b>       |
| VALID VALUES  | Any valid model number/channel count             |
| DEFAULT VALUE | Null   |
| DATA TYPE     | integer  |
| DESCRIPTION   | Lists the module model number and channel count. |

|               |                                     |
|---------------|-------------------------------------|
| VARIABLE      | <b>SERNUM &lt;serial number&gt;</b> |
| VALID VALUES  | Any valid integer                   |
| DEFAULT VALUE | Null                                |
| DATA TYPE     | integer                             |
| DESCRIPTION   | The serial number of the module     |

|               |  |
|---------------|--|
| VARIABLE      | <b>VER &lt;version number&gt;</b>  |
| VALID VALUES  | any valid integer  |
| DEFAULT VALUE | null   |
| DATA TYPE     | integer  |
| DESCRIPTION   | The firmware version Sends the ASCII command string contained in this variable to the host computer binary receiver. |

## Channel Identification Variables (Group DEF)

|               |   |
|---------------|---|
| VARIABLE      | <b>DEF &lt;channel&gt; &lt;definition&gt;</b>   |
| VALID VALUES  | Channel            the channel number<br>Definition        any ASCII string up to 2048 bytes.   |
| DEFAULT VALUE | null  |
| DATA TYPE     | integer   |
| DESCRIPTION   | The variable DEF will be available for each channel in the module up to the highest channel number. The variable is intended to be used as a label or definition of the channel assignment. |

## Limit Variables (Group LI)

|               |  |
|---------------|--|
| VARIABLE      | <b>LIMIT &lt;channel&gt; &lt;enable&gt; [&lt;high limit&gt; low limit]</b>   |
| VALID VALUES  | Channel - 0 to 16, 32, or 64 if 0 is entered all channels will be set.<br>Enable - 0 disables limits<br>1 enables limits<br>High limit - optional, the high limit value<br>Low limit - optional, the low limit value |
| DEFAULT VALUE | Channel - 0<br>Enable - 0<br>High limit - 100<br>Low limit - 0   |
| DATA TYPE     | Integer  |
| DESCRIPTION   | Sets the high and low limits for each channel. When a channel exceeds the low limit, the channel status code will indicate 6000. When the high limit is exceeded, the channel status code will indicate 5000.        |

## Channel Labels (Group LA)

|               |  |
|---------------|--|
| VARIABLE      | <b>LABEL &lt;channel&gt; &lt;label&gt;</b>   |
| VALID VALUES  | Channel - 1 to 16, 32, or 64<br>Label - channel label up to 31 characters. Spaces are allowed. |
| DEFAULT VALUE | Channel - 1<br>Label - T/C <channel>   |
| DATA TYPE     | Channel - Integer<br>Label - ASCII string  |
| DESCRIPTION   | Sets the label for each channel..  |



## Thermocouple Variables (Group T)

| VARIABLE      | TYPE   | <channel> | <type>                                     | [shield connect] |
|---------------|--|-----------|--|------------------|
| VALID VALUES  | channel  | -         | the channel number, 0 through 16, 32 or 64 |                  |
|               | type   | -         | B, E, J, K, N, R, S, or T                  |                  |
| DEFAULT VALUE | channel  | -         | 0  |                  |
|               | type   | -         | K  |                  |
|               | shield connect   | -         | 0  |                  |
| DATA TYPE     | integer  |           |  |                  |
| DESCRIPTION   | Determines the thermocouple conversion for each channel. If the channel is entered as 0, all 16 channels will be set to the thermocouple type specified. The shield connection switch should be set based on the method used to ground or shield the thermocouple. If shield connect is set to 0, the switch will be open. The default setting is 1 or closed. Refer to the figures below for more information on how to properly define this parameter. |           |  |                  |

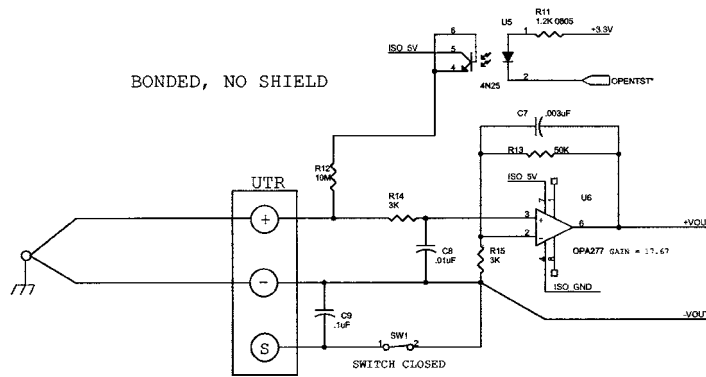

Figure 15 - Bonded Thermocouple, No Shield

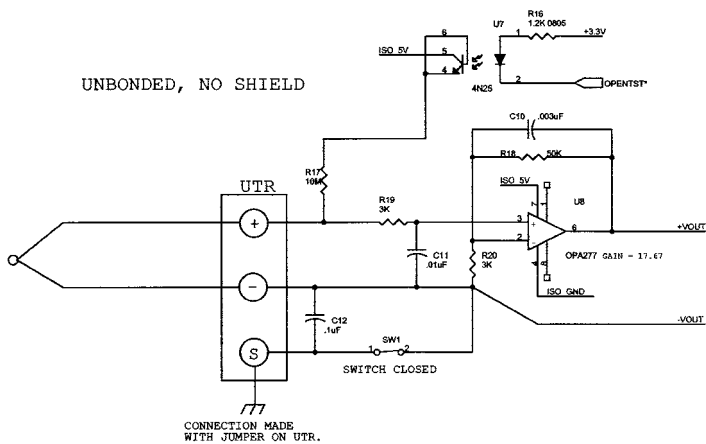

Figure 16 - Unbonded Thermocouple, No Shield

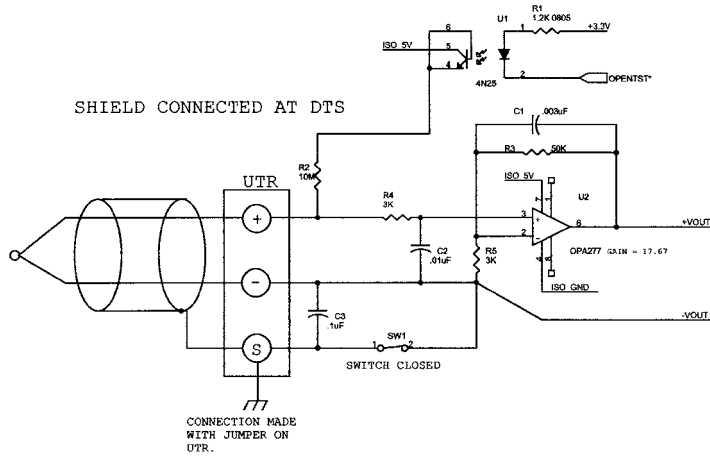

Figure 17 - Shielded Thermocouple, Shield connected at the DTS

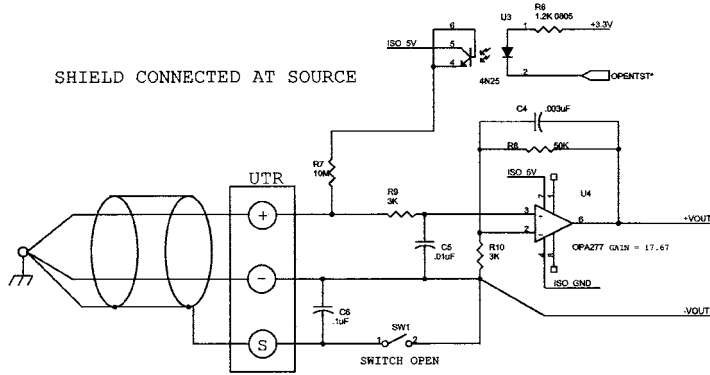

Figure 18 - Shielded Thermocouple, Shield connected at the source

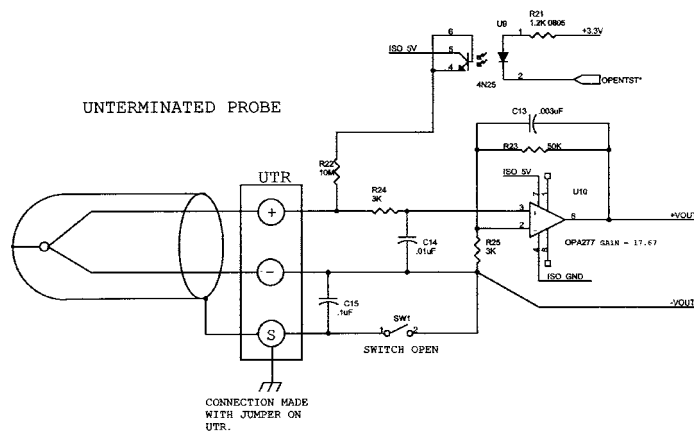

Figure 19 - Unterminated Probe

## RTD Correction Variables (Group RPC)

|               |  |
|---------------|--|
| VARIABLE      | <b>RPC &lt;channel&gt; &lt;index&gt; &lt;volts applied&gt; &lt;counts applied&gt;</b>  |
| VALID VALUES  | Channel - RTD channel, 1, 2, or 4<br>Index - 0 to 7<br>Volts Applied - any valid number<br>Counts Applied - any valid number   |
| DEFAULT VALUE | Channel - 1<br>Index - 0<br>Volts Applied - 0<br>Counts Applied - 0  |
| DATA TYPE     | Index - Integer<br>Volts Applied - float<br>Counts Applied - Integer   |
| DESCRIPTION   | This is the list of setpoints used to calibrate the RTD's. Each RTD pair is corrected by the same setpoints. Each module type has one (1) RTD A/D and consequently one (1) channel for each pair of RTD's. A 16 channel module has 1 channel, a 32 channel module has 2 channels and a 64 channel module has 4 channels. |
| EXAMPLE       | The List RP command is used to view these variables. The variables are set to the following before the initial factory calibration:<br>SET RPC 1 0 0.095000 1287022<br>SET RPC 1 1 0.115000 1557974<br>SET RPC 1 2 0.131000 1774736  |
| NOTE          | The values shown here are values for an ideal RTD channel. The actual calibration setpoints may be different.  |

## RTD Conversion Volts to Ohms (Group RTD)

VARIABLE **RTD 1 <R0> <A> <B>** All Versions  
VALID VALUES any real numbers  
DEFAULT VALUES R0 100.00000  
A 3.908E-03  
B -5.775E-07  
DATA TYPE float  
DESCRIPTION The conversion factors for RTD 1 to convert ohms to millivolts for temperature conversion. The actual values are provided by the manufacturer. The values for A and B must be entered as exponents.

VARIABLE **RTD 2 <R0> <A> <B>** All Versions  
VALID VALUES any real numbers  
DEFAULT VALUES R0 100.00000  
A 3.908E-03  
B -5.775E-07  
DATA TYPE float  
DESCRIPTION The conversion factors for RTD 2 to convert ohms to millivolts for temperature conversion. The actual values are provided by the manufacturer. The values for A and B must be entered as exponents.

VARIABLE **RTD 3 <R0> <A> <B>** 32 and 64 Channel Versions  
VALID VALUES any real numbers  
DEFAULT VALUES R0 100.00000  
A 3.908E-03  
B -5.775E-07  
DATA TYPE float  
DESCRIPTION The conversion factors for RTD 3 to convert ohms to millivolts for temperature conversion. The actual values are provided by the manufacturer. The values for A and B must be entered as exponents.

VARIABLE **RTD 4 <R0> <A> <B>** 32 and 64 Channel Versions  
VALID VALUES any real numbers  
DEFAULT VALUES R0 100.00000  
A 3.908E-03  
B -5.775E-07  
DATA TYPE float  
DESCRIPTION The conversion factors for RTD 4 to convert ohms to millivolts for temperature conversion. The actual values are provided by the manufacturer. The values for A and B must be entered as exponents.

|                |   |                     |
|----------------|---|---------------------|
| VARIABLE       | <b>RTD 5 &lt;R0&gt; &lt;A&gt; &lt;B&gt;</b>   | 64 Channel Versions |
| VALID VALUES   | any real numbers  |                     |
| DEFAULT VALUES | R0 100.00000<br>A 3.908E-03<br>B -5.775E-07   |                     |
| DATA TYPE      | float   |                     |
| DESCRIPTION    | The conversion factors for RTD 1 to convert ohms to millivolts for temperature conversion. The actual values are provided by the manufacturer. The values for A and B must be entered as exponents. |                     |

|                |   |                     |
|----------------|---|---------------------|
| VARIABLE       | <b>RTD 6 &lt;R0&gt; &lt;A&gt; &lt;B&gt;</b>   | 64 Channel Versions |
| VALID VALUES   | any real numbers  |                     |
| DEFAULT VALUES | R0 100.00000<br>A 3.908E-03<br>B -5.775E-07   |                     |
| DATA TYPE      | float   |                     |
| DESCRIPTION    | The conversion factors for RTD 2 to convert ohms to millivolts for temperature conversion. The actual values are provided by the manufacturer. The values for A and B must be entered as exponents. |                     |

|                |   |                     |
|----------------|---|---------------------|
| VARIABLE       | <b>RTD 7 &lt;R0&gt; &lt;A&gt; &lt;B&gt;</b>   | 64 Channel Versions |
| VALID VALUES   | any real numbers  |                     |
| DEFAULT VALUES | R0 100.00000<br>A 3.908E-03<br>B -5.775E-07   |                     |
| DATA TYPE      | float   |                     |
| DESCRIPTION    | The conversion factors for RTD 3 to convert ohms to millivolts for temperature conversion. The actual values are provided by the manufacturer. The values for A and B must be entered as exponents. |                     |

|                |   |                     |
|----------------|---|---------------------|
| VARIABLE       | <b>RTD 8 &lt;R0&gt; &lt;A&gt; &lt;B&gt;</b>   | 64 Channel Versions |
| VALID VALUES   | any real numbers  |                     |
| DEFAULT VALUES | R0 100.00000<br>A 3.908E-03<br>B -5.775E-07   |                     |
| DATA TYPE      | float   |                     |
| DESCRIPTION    | The conversion factors for RTD 4 to convert ohms to millivolts for temperature conversion. The actual values are provided by the manufacturer. The values for A and B must be entered as exponents. |                     |

## Channel Gain Correction Variables (Group G)

|               |  |
|---------------|--|
| VARIABLE      | <b>GAIN &lt;channel&gt; &lt;gain value&gt;</b>   |
| VALID VALUES  | any real number  |
| DEFAULT VALUE | 1  |
| DATA TYPE     | float  |
| DESCRIPTION   | Sets the GAIN correction for a given channel using the formula:<br>$\text{Adjusted Counts} = (\text{GAIN} * \text{counts}) + \text{OFFSET}.$ |

## Channel Offset Correction Variables (Group O)

|               |  |
|---------------|--|
| VARIABLE      | <b>OFFSET &lt;channel&gt; &lt;gain value&gt;</b>   |
| VALID VALUES  | any real number  |
| DEFAULT VALUE | 1  |
| DATA TYPE     | float  |
| DESCRIPTION   | Sets the OFFSET correction for a given channel using the formula:<br>$\text{Adjusted Counts} = (\text{GAIN} * \text{counts}) + \text{OFFSET}.$ |



## DTS Packet Definitions

When requested the DTS sends an application packet to the client. Each packet sent to the client starts with a Packet Type Word. This word defines the packet type.

### Packet Type Table

| PACKET NAME     | PACKET ID | BYTES    | NOTES  |
|-----------------|-----------|----------|--|
| 16 Channel Data | 0Hex      | 168      |  |
| Host Control    | 1Hex      | 168      | Command Packet   |
| 32 Channel Data | 2Hex      | 304      |  |
| 64 Channel Data | 3Hex      | 576      |  |
| ASCII           | 20Hex     | Variable | Text Packet may be formatted or un-formatted. The format is determined by the setting of the FORMAT Configuration Variable.<br><b>NOTE:</b> When the first integer of the packet is 20Hex or greater, the packet is assumed to be in ASCII FORMAT. |

## Host Control Packets

### Command Packet

| FUNCTION DESCRIPTION   | BYTES | DESCRIPTION  |
|--|-------|--|
| Packet Type  | 4     | 1Hex   |
| Host ASCII Command Data (Refer to the Command Section of this manual for more information) | 164   | ASCII string received by DTS as the Host command.<br>Each line must be terminated with a CR, LF, CR-LF or LF-CR. |



# DTS to HOST

## Binary Data Packets

### DTS3250/16 Channel Module

| FUNCTION               | BYTES | DATA TYPE | DESCRIPTION   |
|------------------------|-------|-----------|---|
| Packet Type            | 4     | Integer   | 0Hex  |
| General Status         | 4     | Integer   | Refer to Table 1 in this section  |
| Frame Number           | 4     | Integer   | The current frame number if in the scan mode                                    |
| Temperature 1 to 16    | 64    | Float     | Channel temperatures in units set by bits 4 - 6 of the General Status Byte.     |
| RTD1 Temperature       | 4     | Float     | Temperature in units defined by the setting of the variable: UNITS. See Table 3 |
| RTD2 Temperature       | 4     | Float     | Temperature in units defined by the setting of the variable: UNITS. See Table 3 |
| Time Stamp             | 4     | Integer   | Time Stamp in units set by bit 8 of the General Status Byte.                    |
| Channel Status 1 to 16 | 64    | Integer   | Refer to Table 2 in this section  |
| Spares                 | 16    | Integer   | Spares  |

## DTS3250/32 Channel Module

| FUNCTION               | BYTES | DATA TYPE | DESCRIPTION  |
|------------------------|-------|-----------|--|
| Packet Type            | 4     | Integer   | 2Hex   |
| General Status         | 4     | Integer   | Refer to Table 1 in this section   |
| Frame Number           | 4     | Integer   | The current frame number if in the scan mode                                     |
| Temperature 1 to 32    | 128   | Float     | Channel temperatures in units set by bits 4 - 6 of the General Status Byte.      |
| RTD1 Temperature       | 4     | Float     | Temperature in units defined by the setting of the variable: UNITS. See Table 3  |
| RTD2 Temperature       | 4     | Float     | Temperature in units defined by the setting of the variable: UNITS. See Table 3  |
| RTD3 Temperature       | 4     | Float     | Temperature in units defined by the setting of the variable: UNITS. See Table 3. |
| RTD4 Temperature       | 4     | Float     | Temperature in units defined by the setting of the variable: UNITS. See Table 3  |
| Time Stamp             | 4     | Integer   | Time Stamp in units set by bit 8 of the General Status Byte.                     |
| Channel Status 1 to 32 | 128   | Integer   | Refer to Table 2 in this section   |
| Spares                 | 16    | Integer   | Spares   |

## DTS3250/64 Channel Module

| FUNCTION               | BYTES | DATA TYPE | DESCRIPTION   |
|------------------------|-------|-----------|---|
| Packet Type            | 4     | Integer   | 3Hex  |
| General Status         | 4     | Integer   | Refer to Table 1 in this section  |
| Frame Number           | 4     | Integer   | The current frame number if in the scan mode                                    |
| Temperature 1 to 64    | 256   | Float     | Channel temperatures in units set by bits 4 - 6 of the General Status Byte.     |
| RTD1 Temperature       | 4     | Float     | Temperature in units defined by the setting of the variable: UNITS. See Table 3 |
| RTD2 Temperature       | 4     | Float     | Temperature in units defined by the setting of the variable: UNITS. See Table 3 |
| RTD3 Temperature       | 4     | Float     | Temperature in units defined by the setting of the variable: UNITS. See Table 3 |
| RTD4 Temperature       | 4     | Float     | Temperature in units defined by the setting of the variable: UNITS. See Table 3 |
| RTD5 Temperature       | 4     | Float     | Temperature in units defined by the setting of the variable: UNITS. See Table 3 |
| RTD6 Temperature       | 4     | Float     | Temperature in units defined by the setting of the variable: UNITS. See Table 3 |
| RTD7 Temperature       | 4     | Float     | Temperature in units defined by the setting of the variable: UNITS. See Table 3 |
| RTD8 Temperature       | 4     | Float     | Temperature in units defined by the setting of the variable: UNITS. See Table 3 |
| Time Stamp             | 4     | Integer   | Time Stamp in units set by bit 8 of the General Status Byte.                    |
| Channel Status 1 to 64 | 256   | Integer   | Refer to Table 2 in this section  |
| Spares                 | 16    | Integer   | Spares  |

## General Status Byte

Bits 0 - 3      Not used

Bits 4 - 6      Temperature Units

Bit 7            Not Used

Bit 8            Time Stamp

Bits 9 - 11     Not Used

Bits 12 - 15    RTD Delta Errors

**Table 1 - General Status Byte**

| Bit                              | 15 | 14 | 13 | 12 | 11 | 10 | 9 | 8 | 7 | 6 | 5 | 4 | 3 | 2 | 1 | 0 |
|----------------------------------|----|----|----|----|----|----|---|---|---|---|---|---|---|---|---|---|
| 0 - Raw A/D Counts (Uncorrected) | X  | X  | X  | X  | X  | X  | X | X | X | 0 | 0 | 0 | X | X | X | X |
| V - Raw Voltage (Uncorrected)    | X  | X  | X  | X  | X  | X  | X | X | X | 0 | 0 | 1 | X | X | X | X |
| A - Corrected Voltage            | X  | X  | X  | X  | X  | X  | X | X | X | 0 | 1 | 0 | X | X | X | X |
| C - Degrees C                    | X  | X  | X  | X  | X  | X  | X | X | X | 0 | 1 | 1 | X | X | X | X |
| F - Degrees F                    | X  | X  | X  | X  | X  | X  | X | X | X | 1 | 0 | 0 | X | X | X | X |
| K - Degrees K                    | X  | X  | X  | X  | X  | X  | X | X | X | 1 | 0 | 1 | X | X | X | X |
| R - Degrees R                    | X  | X  | X  | X  | X  | X  | X | X | X | 1 | 1 | 0 | X | X | X | X |
| Number of Temp Scales (Not Used) | X  | X  | X  | X  | X  | X  | X | X | X | 1 | 1 | 1 | X | X | X | X |
| Time Stamp in microseconds       | X  | X  | X  | X  | X  | X  | X | X | 0 | X | X | X | X | X | X | X |
| Time Stamp in milliseconds       | X  | X  | X  | X  | X  | X  | X | X | 1 | X | X | X | X | X | X | X |
| No Errors                        | 0  | 0  | 0  | 0  | X  | X  | X | X | X | X | X | X | X | X | X | X |
| UTR1 Delta Error (16, 32, 64)    | 0  | 0  | 0  | 1  | X  | X  | X | X | X | X | X | X | X | X | X | X |
| UTR2 Delta Error (32, 64)        | 0  | 0  | 1  | 0  | X  | X  | X | X | X | X | X | X | X | X | X | X |
| UTR3 Delta Error (64)            | 0  | 1  | 0  | 0  | X  | X  | X | X | X | X | X | X | X | X | X | X |
| UTR4 Delta Error (64)            | 1  | 0  | 0  | 0  | X  | X  | X | X | X | X | X | X | X | X | X | X |

## Channel Status Byte

Bits 0 - 4      Thermocouple Type  
 Bits 5 - 11    Not Used  
 Bits 12 - 15   Error Codes

**Table 2 - Channel Status Byte**

| Bit                 | 15 | 14 | 13 | 12 | 11 | 10 | 9 | 8 | 7 | 6 | 5 | 4 | 3 | 2 | 1 | 0 |
|---------------------|----|----|----|----|----|----|---|---|---|---|---|---|---|---|---|---|
| Type J              | X  | X  | X  | X  | X  | X  | X | X | X | 0 | 0 | 0 | 0 | 0 | 0 | 0 |
| Type E              | X  | X  | X  | X  | X  | X  | X | X | X | 0 | 0 | 0 | 0 | 0 | 0 | 1 |
| Type K              | X  | X  | X  | X  | X  | X  | X | X | X | 0 | 0 | 0 | 0 | 0 | 1 | 0 |
| Type N              | X  | X  | X  | X  | X  | X  | X | X | X | 0 | 0 | 0 | 0 | 0 | 1 | 1 |
| Type R              | X  | X  | X  | X  | X  | X  | X | X | X | 0 | 0 | 0 | 0 | 1 | 0 | 0 |
| Type S              | X  | X  | X  | X  | X  | X  | X | X | X | 0 | 0 | 0 | 0 | 1 | 0 | 1 |
| Type T              | X  | X  | X  | X  | X  | X  | X | X | X | 0 | 0 | 0 | 0 | 1 | 1 | 0 |
| Type B              | X  | X  | X  | X  | X  | X  | X | X | X | 0 | 0 | 0 | 0 | 1 | 1 | 1 |
| A/D Disabled        | 0  | 0  | 0  | 1  | X  | X  | X | X | X | X | X | X | X | X | X | X |
| Open T/C            | 0  | 0  | 1  | 0  | X  | X  | X | X | X | X | X | X | X | X | X | X |
| High Range Error    | 0  | 0  | 1  | 1  | X  | X  | X | X | X | X | X | X | X | X | X | X |
| Low Range Error     | 0  | 1  | 0  | 0  | X  | X  | X | X | X | X | X | X | X | X | X | X |
| High Limit Exceeded | 0  | 1  | 0  | 1  | X  | X  | X | X | X | X | X | X | X | X | X | X |
| Low Limit Exceeded  | 0  | 1  | 1  | 0  | X  | X  | X | X | X | X | X | X | X | X | X | X |

**Table 3 - RTD Units**

| UNITS | RTD Units  |
|-------|------------|
| A     | millivolts |
| C     | Degrees C  |
| F     | Degrees C  |
| K     | Degrees C  |
| R     | Degrees C  |
| V     | millivolts |
| 0     | A/D counts |

## ASCII Data Packet

This packet will be transmitted when the host issues one of the following commands:

- 1) SCAN with BIN set to 0
- 2) LIST n
- 3) ERROR
- 4) STATUS

| FUNCTION DESCRIPTION   | BYTES     | DATA TYPE | VALUE  |
|--|-----------|-----------|--|
| ASCII Data (The first two bytes must <b>NOT</b> be 1Hex through 1FHex). Refer to the Command Section of this manual for the proper Command return formats. | 1 to 1492 | String    | Unique to Packet.<br>Each line is terminated with a CR, LF, CR-LF, or LF-CR. |

## Network Protocols Supported

Physical Layer :       10Base-T       IEEE 802.3  
Link Layer:            INTERNET Protocol (IP)  
Transport Layer:      Transmission Control Protocol (TCP)  
                          User Datagram Protocol (UDP)

## Operation

This section contains information and procedures required for the proper operation of DTS3250 Modules.

### Ethernet Connections

All DTS3250 Modules are equipped with an Ethernet port. The Ethernet speed is 100Base-T connections.. No variables need to be modified to use this connection.

#### IP Address

All DTS3250 Modules have a preset IP address that can be modified by a user, if desired. The preset IP address for each type is:

|                |  |
|----------------|--|
| DTS3250/16Tx - | 191.30.55.xxx where xxx is the serial number of the unit.  |
| DTS3250/32Tx - | 191.30.60.xxx where xxx is the serial number of the unit.  |
| DTS3250/64Tx - | 191.30.160.xxx where xxx is the serial number of the unit. |

The IP Address in a DTS3250 module may be changed by the user. IP Address may only be modified using the Serial Port during the boot up process. A procedure for this may be found in the DTS3250 Boot Parameter Modification Section.

### Network Identification

DTS3250 Modules may be interrogated by a network host. This is similar to a “Whois” command. DTS3250 modules listen on port 7000 for a IP broadcast. The format of this broadcast must be 255.255.255.255 or any IP address with 255 set in the octet where the subnet mask is set to 0. When this is received, the DTS3250 will respond on port 7001 with the following:

<IP Address>, <Model/channels>, <Sernum> from ADDR: <IP Address>

For more information, please refer to the LIST ID command, or the Network Identification Group configuration variables.

## TelNet Host Operation - Windows 95 and 98

A host computer may be used to control a DTS3250 Module without special software. The host to DTS3250 connection should be made using an Ethernet connection.

Open a **TelNet** session.

Select: Terminal

Select: Preferences

Enable Local Echo

Set the Emulation to VT100/ANSI

Select: Connect

Select: Remote System

Host Name: Enter: 191.30.yyy.xxx Where: yyy is the model octet  
xxx is the serial number octet

Port: Select: Telnet

TermType: Select: vt100

If the computer opens a Dial Up Box,

Click on Cancel

When the TelNet session is open, any command listed in the Software Requirements Specification may be entered. Responses will be displayed in the TelNet Window. Please refer to the Software Section of this manual.

## HyperTerminal Ethernet Operation - Windows NT, 2000, and XP

Open the HyperTerminal program

Select: Start

Select: Programs

Select: Accessories

Click on Hyperterminal

A HyperTerminal Window will open

Double Click: Hyperterminal.exe

A New Connection Window will open

Enter a name for the session and Click OK

A Connect to Window will open

Click on the down arrow by the Connect Using Box and click on TCP/IP(Winsock)

Enter the IP address of the DTS3250 Module in the Host Address Box

The HyperTerminal window will indicate that a connection has been made.

Check the setup

Select: File

Select: Properties

A Properties Window will open.

Click on the Settings Tab

Emulation Mode should be Auto Detect

Terminal should be ANSI

Click on the ASCII Setup Button

For best operation, The check boxes for:

Send line ends with line feeds, and Echo typed characters locally may have to be checked



## DTS3250 Recommended Operation

1. Energize the unit and allow 3 hours for warm-up.
2. While the unit is warming up, connect the thermocouples to the inputs.
3. Verify that the thermocouple types are set correctly. The following command should be used:  
List T 0            All channels will be listed. The thermocouple type will be shown as well as the shield connection. Refer to the figures in Thermocouple variable group section for more information.
4. Enter labels for the thermocouples, if desired. The current label entries may be viewed by the following command:  
List LA            Labels may be changed by using the SET LABEL x function where x is the channel number.
5. Enter channel range limits. This is the number that will be displayed if the input exceeds the calibrated range of the unit. Refer to RANGEV and RANGET variables for more information.
6. Enter channel limits. These are the temperature limits that will be used for alarm outputs. The current channel limits may be viewed by typing:  
List LI
7. Verify the SCAN variable settings. Type:  
List S            The scan variables will be listed. Set PERIOD, AVG or RATE to obtain the desired scan rate
8. When the unit has completed the warmup, Issue the following commands:  
ADCAL            Re-zero the A/D converters  
OTC              Test for open thermocouples  
ERROR            Check for errors
9. If no errors are logged, the unit is ready for test.
10. It is also recommended that the user check for errors every time the ADCAL command is executed. If an A/D times out or does not respond correctly during the execution of that command, the A/D will be disabled in software. The only indication that this has occurred will be an error logged in the error buffer.

## Special Operational Notes

1. If any RTD reading is outside the range  $-10.0^{\circ}\text{C}$  to  $70.0^{\circ}\text{C}$ , the last good reading is used. NO error will be logged.
2. If any thermocouple reading is outside the range for that thermocouple type, the last good reading is used. NO error will be logged. Please refer to the standard NIST tables for the range of each supported thermocouple type.
3. If any A/D converters are disabled due to errors, an error will be logged and bit 12 of the channel status element in the data packet will be set.

## DTS3250 Boot Parameter Modification

The DTS3250 Series modules use an operating system licensed from VxWorks. The boot parameters are set at the factory, but these parameters may be modified to suit the needs of a specific installation. This section documents the modification of the boot parameters.

1. De-energize the DTS3250. Connect the DTS3250 trigger/serial test cable (Scanco part #155829) from the DTS3250 to a host PC.
2. Start HyperTerminal, or an equivalent communication program. Connect the DTS3250 to a COM port on the PC Host. Set the serial parameters to 9600 BAUD, no parity, 8 data bits and 1 stop bit.
3. Energize the DTS3250. The following sign-on information should be displayed.

```
VxWorks System Boot
Copyright 1984-1997 Wind River Systems, Inc.
```

```
CPU: HITACHI hs7709
Version: 5.3.1
BSP version: 1.1/0
Creation date: Feb 9 2000, 12:41:05
```

```
Scanivalve (c)2000, Boot loader version 1.01
Press any key to stop auto-boot...
```

4. Press any key within 3 seconds to stop the auto-boot process. If a key is not pressed within the 3 seconds time, the system will proceed to auto-boot with the existing operating system using the current setup.  
NOTE: The boot-loader will continue to reboot until stopped by pressing a key under the following conditions:
  - A. If boot-from-flash is selected, and no operating system is present in flash.
  - B. if boot-from-net is selected and the FTP server is not correctly set up.

5. When the auto-boot process is stopped, the boot-loader will prompt with:  
[VxWorks Boot]:

To get a list of the existing boot parameters:

```
Type: p <Enter>
```

The following list is the default setup:

```
boot device           : cs
processor number      : 0
host name             : host
file name             : c:/dsa_hs/vxWorks.st
inet on ethernet (e) : 191.30.60.100
host inet (h)        : 191.30.101.109
user (u)             : DSA_HS
ftp password (pw)    : scanivalve
flags (f)            : 0x0
other (o)            : flash,000.096.093.250.000.002,10baseT
```

6. Modify the parameters as required by typing the change command at the [VxWorks Boot] prompt  
Type: c<Enter>            The boot-loader prompts you for each parameter.  
  
If a particular field has the correct value and does not need to be changed,  
Press: <Enter>  
**NOTE:** If any other key is pressed, that will replace the existing information.  
  
To clear a field,  
Type: . <Enter>  
  
To quit before viewing all of the parameters,  
Type: CTRL+D.
7. After all changes have been made, verify the settings:  
Type: p<Enter>            The settings are saved in flash at this point.
8. Restart the operating system, with the new settings,  
Type: @<Enter>            This is the "Load and Go" command.
9. If the DTS3250 boots correctly, de-energize the DTS3250 and disconnect the serial test cable.
10. Re-apply power to the DTS3250.

## Boot parameters and their functions:

|                       |  |
|-----------------------|--|
| boot device           | Must not be changed from cs  |
| processor number      | Must not be changed from 0   |
| host name             | Must not be changed from host.   |
| file name             | The full pathname of the operating system file name to be booted from, when booting from the network. The default path and file in this line is the path and file used at Scanivalve.  |
| inet on ethernet(e)   | The IP address of this DTS3250.<br>Although it is not necessary, The subnet mask may be specified when entering this parameter by entering a colon followed by the subnet mask in hex notation. I.e. 191.30.85.100:FFFFFF00  |
| inet on backplane (b) | Must be left blank   |
| host inet (h)         | The IP address of the host for boot from net, or file upload   |
| gateway inet (g)      | The IP address of a gateway node if the host is not on the same network as the DTS3250.  |
| user (u)              | The user name that the DTS3250 uses to access the host. This is the name that must be set up in the FTP server on the host. The FTP server must be set up to provide that user name with the proper permission to read from the host directory and the password must be set correctly.   |
| ftp password (pw)     | The user password. This must be supplied to boot from host.  |
| flags (f)             | Must be 0x0  |
| target name (tn)      | Must be blank  |
| startup script (s)    | Must be blank  |
| other (o)             | This specifies the place to boot from, the MAC address, and the network media. The line must not contain any spaces and each parameter is separated by a comma. The syntax is:<br><bootloc>,<mac address>,<media type><br>Valid values are case sensitive and are as follows:<br><bootloc> net - Boot from network<br>flash - Boot from flash.<br><mac address> ddd.ddd.ddd.ddd.ddd.ddd<br><media type> 10base2 - 10Base2 type<br>10baset - 10BaseT type |

## DTS3250 Operating System Upload

This section describes the method for upgrading and uploading a new operating system to the DTS3250. Two programs are used in the DTS3250, the boot-loader and the operating system/DTS3250 application, referred to as the operating system.

The purpose of the boot-loader is to start the operating system from local flash or from a location on the network, such as a disk file on a host PC and to allow setting of certain key operating system parameters. The boot-loader can only be installed with special flash programming equipment. However, the boot-loader, under most normal upgrade conditions, would not need to be changed.

When upgrading a new DTS3250 operating system, the following procedure should be followed:

1. Install an FTP server, on your host PC. Scanivalve Corp recommends the War Daemon FTP Server. The installation is described in the FTP Server Installation/Configuration Procedure.
2. Use the boot parameter modification procedure to modify the boot parameters:
  - A. Change the file name parameter to the location of the vxWorks.st file.
  - B. Change the host IP address to match the host computer.
  - C. Insure that the user parameter is set to DSA\_HS. It must match the user in the FTP server. This name may be modified by a user
  - D. Set the password to scanivalve. It must match the password in the FTP server. The password may be modified by a user.
3. Connect to the DTS3250 using TelNet
4. Issue the "UPLOAD S <full file path>" command from TelNet. Only back slashes can be used in the path name and the S must be upper case.
5. Monitor the operation with the STATUS command. When it returns READY, the upload is complete. The upload will require about 2.5 minutes to complete. If READY is returned immediately, something has been entered incorrectly.
6. When the DTS3250 returns READY, The new operating system is installed in flash memory, but not in RAM.
7. The new operating system will be effective when power is recycled.

## DTS3250 Buffer Description

The DTS3250 buffer is a software buffer. It is set up as a FIFO. It is factory set to hold 10000 averaged frames of data. Each frame uses 292 bytes of memory.

The software buffer is always in use regardless of the setting of QPKTS variable. The effect of QPKTS occurs when the buffer is filled. If QPKTS is set to 1, the scan will stop when the buffer is full. If QPKTS is set to 0, subsequent frames will be discarded when the buffer is full.

The buffer is the liaison between the scan task and the scan output task. The scan output task has a higher priority than the scan task. Under initial conditions, when the buffer is empty, the scan task places one frame of data in the buffer. It then signals the scan output task to read the buffer until it is empty. However, when multiple frames of data are in the buffer, the output task continues until the buffer is empty. Multiple frames of data will accumulate if the scan output task is blocked by the network while outputting data.

## WarFTP Server

### Installation

Copy the file: Warftp.exe into a temporary directory.

Double click: Warftp.exe to unzip the installation files.

Double click: Setup.exe

A window will open prompting for an installation directory. Click Next.

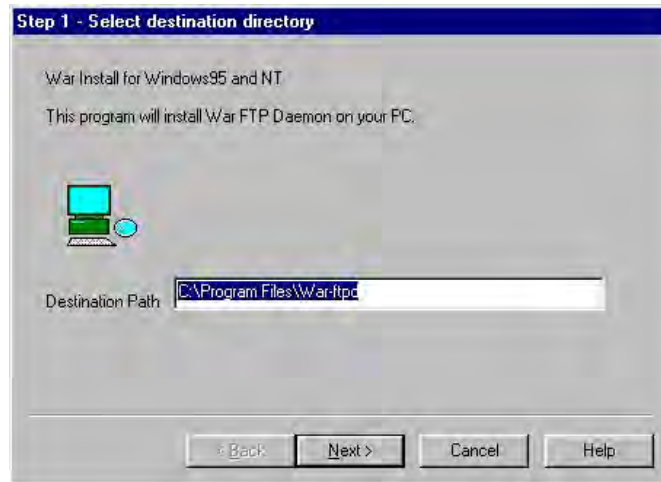

A window will open prompting for an installation type.

Select: Typical, and click Next.

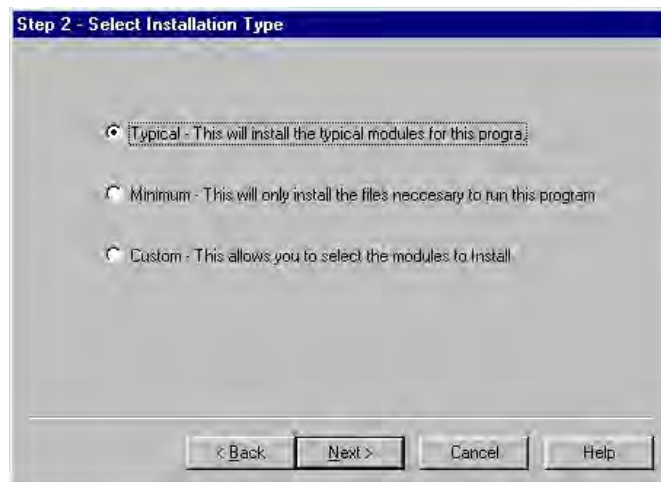

A Window will open prompting for a program folder. Use the default folder, and click Next.



A window will open prompting to finish the installation.  
Click: Finish to complete the installation.

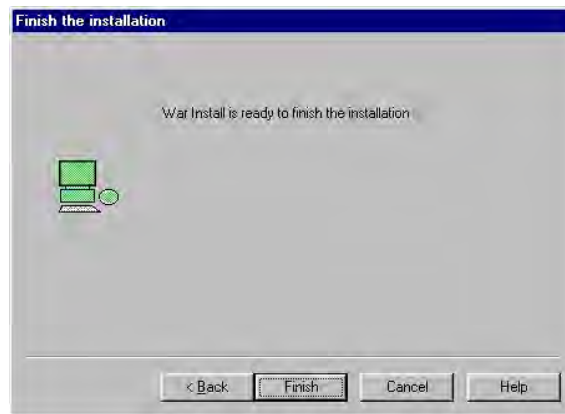

If the installation is successful, a window will open with this message. Click OK



Create a folder for the DTS files.

Create the directory: C:\DTS\_HS.

Copy the file: VxWorks into this directory.

## Configuration and Setup

Start the application by double clicking the war-ftp.exe icon in the C:\Program Files\War-ftp directory.



The War FTP Daemon information window will open  
Enable the "Do not show this banner again" check box and click OK.



The main display window will open. It will look similar to the window below.

Select: Properties  
Select: Options

From the General Tab, Enable the "Go online when started and minimize" check boxes.

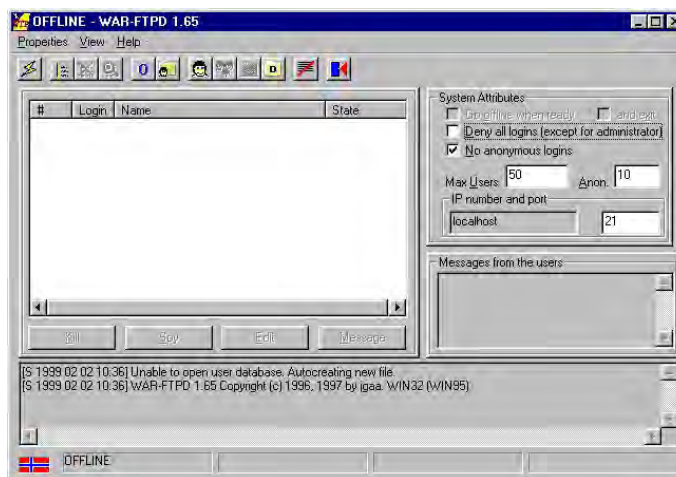



Select the Server Name Tab.

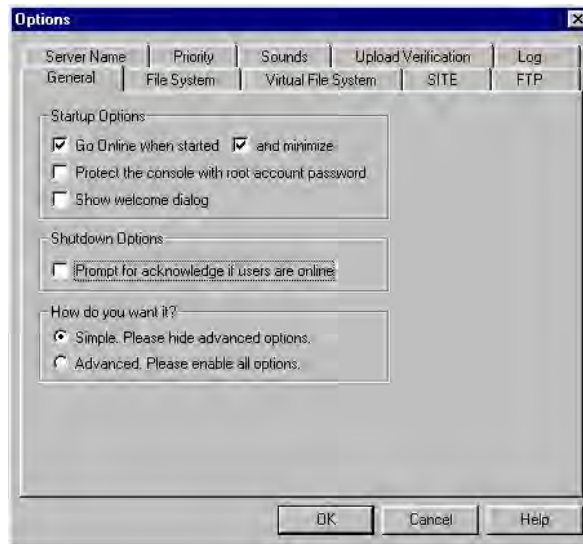

Enter a name for the FTP server.  
In this example the server will be named : host.  
Click OK.

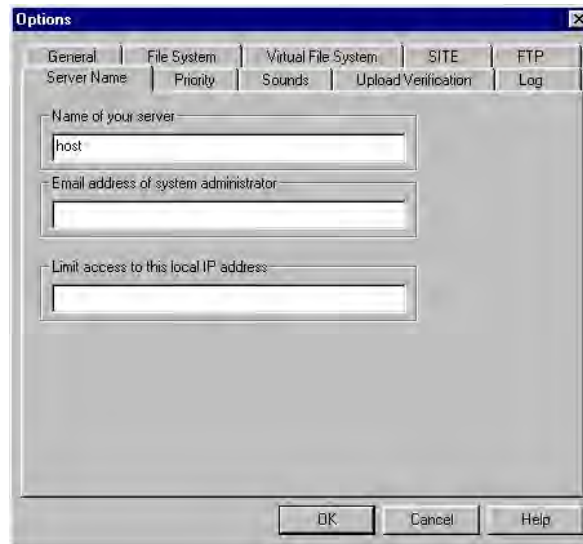

The main window will re-open

Open the User Maintenance window:  
Click on the large smiling face icon

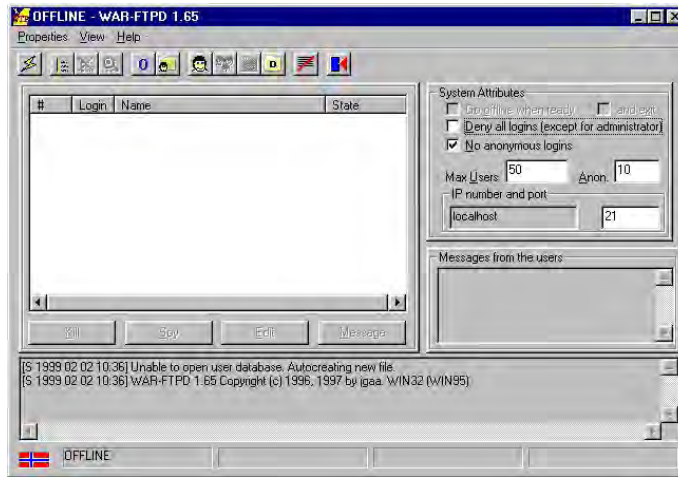

When the User Maintenance Window opens,  
Click the Add button

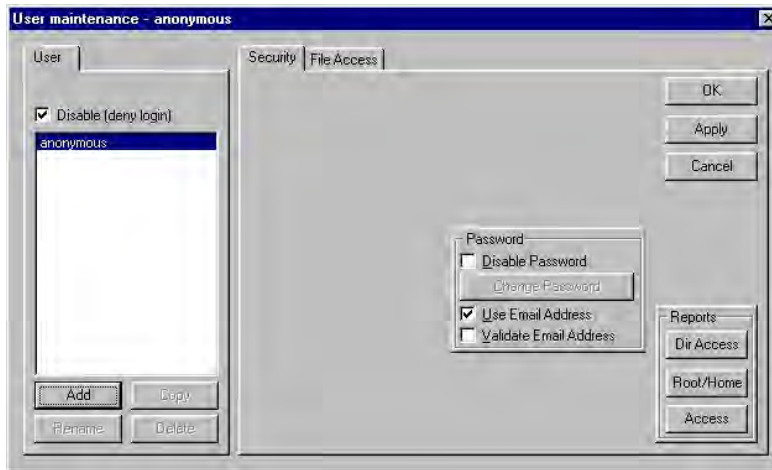

A window will open prompting a User name for the DTS.  
Enter a user name for the DTS.  
For this example, the User Name will be: DTS\_HS  
Click OK.



Another window will open prompting for a password  
Enter a password for the DTS.  
For this example, the password will be: scanivalve.  
Click OK.



The User Maintenance window will re-open.  
Highlight DTS\_HS  
Select the File Access Tab  
Click on the Add Button.

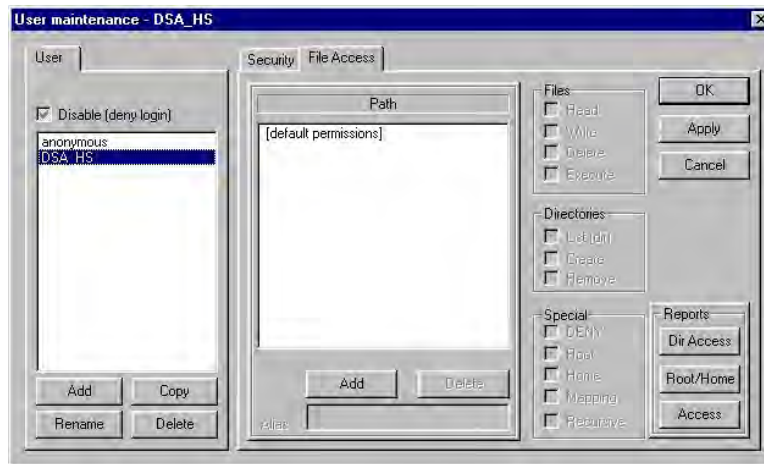

A Select Directory Window will open  
Highlight the DTS\_HS directory.  
Click OK.



Enable the Read and Write checkboxes in the Files frame.

Click : Apply

Click: OK

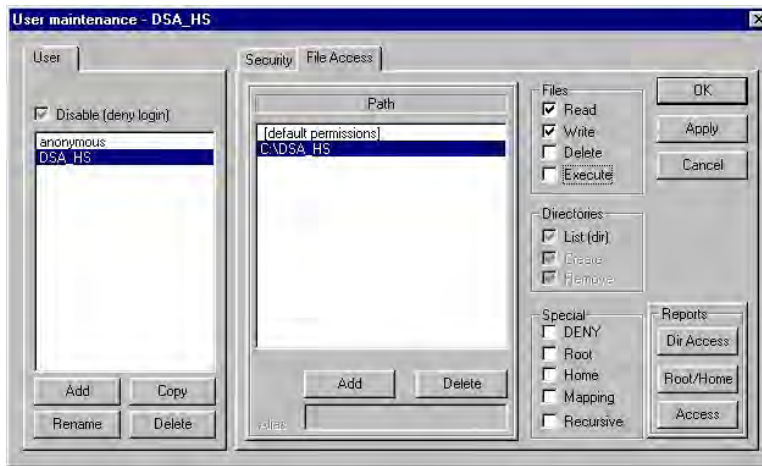

The Main Window will re-open

Put the server online:

Click on the lightning bolt..

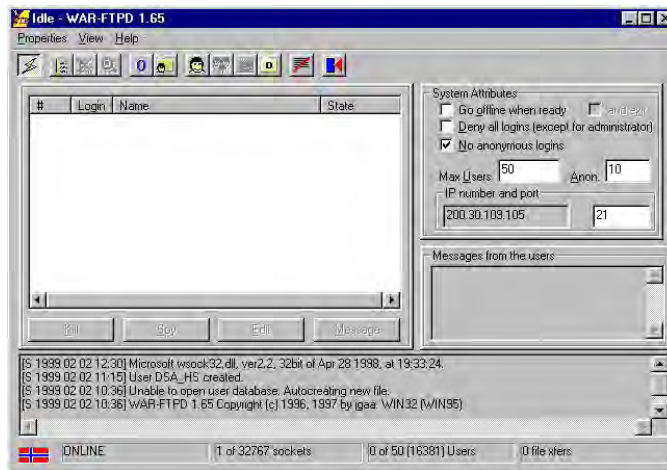

The WarFTP server is now ready

The server can be started manually as needed, or it could be configured to start automatically by placing a shortcut to War-Ftpd.exe in the Windows/Start Menu directory.

## Appendix A - Accessories

### Power Supply - PDM 1500

A single output 24 Vdc power supply is available as an accessory to the DTS3250. This power supply will drive one DTS3250. The Scanivalve part number is 145078-1. The unit will operate from 100 to 240 Vac at 47 to 63 Hz. The output is 24 Vdc at 2.5 A. A 10 foot (3 meter) interconnecting cable, Scanivalve part number 155819-1, is included. Longer cables are available. For more information on the power supply and cables, contact Scanivalve Corp, Customer Service Department.

NOTE: The PDM1500 is a direct replacement for the previous PDM1000 power supply.

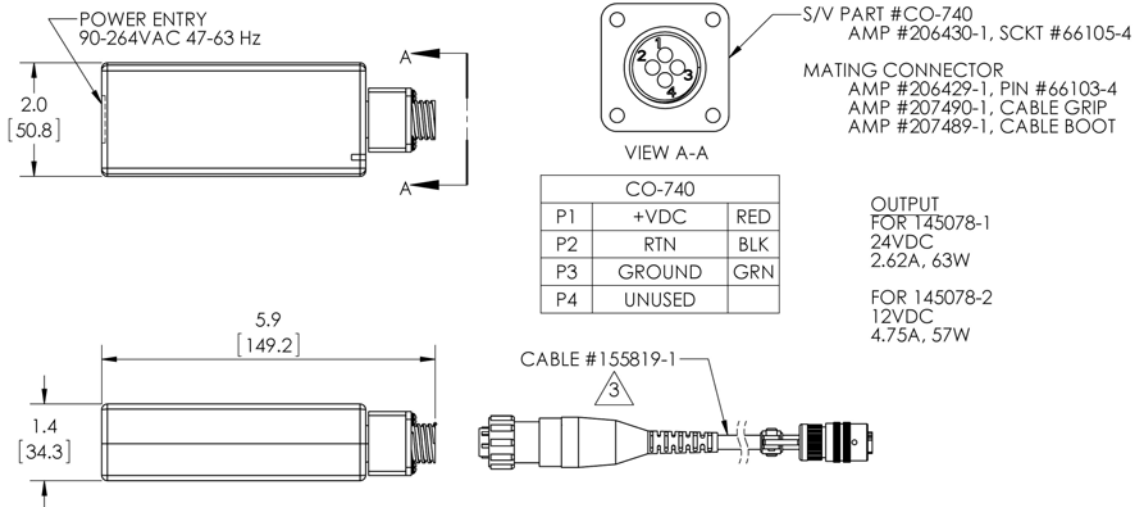



## Appendix B - Thermocouple Information

### Thermocouple Basics

When two dissimilar metals are joined together to form a closed loop, and if one junction is held at a different temperature from the other, an Electromotive Force (EMF) is generated. The amount of EMF generated is predictable based on the materials used and the temperature of the junction.

The EMF is generated by the wires, not the junction. A temperature gradient must exist before the EMF can be generated.

Three laws have been established that govern thermoelectric circuits.

#### Law of Homogeneous Materials

A thermoelectric current cannot be sustained in a circuit of a single homogeneous material, however it varies in cross section, by the application of heat alone.

Simply stated, two different materials are required for any thermocouple circuit. If current can be detected in a homogeneous wire when it is heated, this is evidence that the wire is inhomogeneous.

#### Law of Intermediate Materials

The algebraic sum of the thermoelectromotive forces in a circuit composed of any number of dissimilar materials is zero if all of the circuit is at a uniform temperature.

This law states that a third homogeneous material can be added to a circuit with no effect on the net EMF of the circuit as long as temperature of the junctions remain the same.

#### Law of Successive or Intermediate Temperature

If two dissimilar homogeneous materials produce a thermal EMF of  $E_1$  when the junctions are at temperature  $T_1$  and  $T_2$ , and a thermal EMF of  $E_2$  when the junctions are at  $T_2$  and  $T_3$ , the EMF generated when the junctions are at  $T_1$  and  $T_3$  will be  $E_1 + E_2$ .

This law states that a thermocouple calibrated for one reference temperature can be used with any other reference temperature with a correction. Also, extension wires having the same characteristics as those of the thermocouple wires can be introduced to the circuit without affecting the circuit.

#### Thermocouple Circuits

A basic thermocouple circuit consists of two dissimilar homogeneous materials extending from the measuring junction to the reference junction.

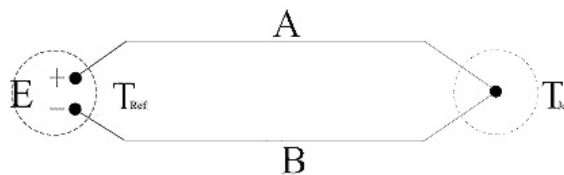

When more than one thermocouple is to be measured, each thermocouple should be two continuous wires between the measuring and reference junctions. This is the most common circuit for thermoelectric testing.

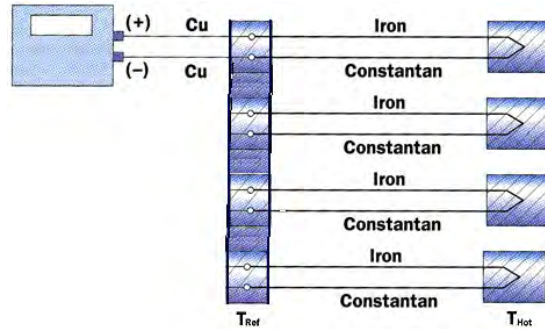

### Thermocouple Accuracy

Thermocouple accuracy can be defined as relative and absolute accuracy.

#### Relative Accuracy

This is the ability of the system to repeat a given measurement. This depends upon the quality of the sensors, the measuring system used and how the system is installed.

#### Absolute Accuracy

This is the ability of the system to determine a standard accepted value. This can be achieved by calibration relative accepted and recognized standards.

### Thermocouple Calibration

Calibration will not change the characteristics of a thermocouple. It does validate the system and ensure proper readings by allowing corrections to be entered for each thermocouple in the system. Calibrations should conform to ISO 10012-1:1992.

## Sources of Error in Thermocouple Measurements

### Measuring Junction

The thermocouple junction at the temperature measuring point is the measuring junction. Errors at this point depend upon the age of the junction, the method of joining and materials used to form the junction. Generally, errors from the measuring junction are small.

### Extension Wires

Extension wires are any elements inserted between the measuring junction and the reference junction. Extension wires should have the same characteristics as the thermocouple wire. Extension wires introduce four junctions to each circuit. This can cause errors as large as  $\pm 2$  °C. The errors can be minimized by calibrating the system with the extension wires in place. If possible, extension wires should not be used.



#### Reference Junctions

The thermocouple junction maintained at a known temperature is the reference junction. Reference junctions can introduce errors as large as  $\pm 0.6$  °C.

#### Copper Connecting Wires

These wires are used to connect the reference junction to the measuring device. The errors caused by these wires are very small.

#### Thermocouple Switches

When used, these devices can induce errors as large as  $\pm 1$  °C. Switching should occur in the copper wires between the reference junction and the measuring device.

## Noise in Thermocouple Circuits

The external effects that can cause errors in thermocouple circuits include: electrical and magnetic fields, cross-talk, and common mode voltage.

Electric fields radiated from voltage sources are capacitively coupled to thermocouple extension wires. This imposes an AC voltage on the thermoelectric EMF. This can be minimized by shielding the thermocouple extension wire and grounding the shield.

Magnetic fields produce noise current in the thermocouple extension wire. This can be minimized by twisting the thermocouple extension wire pairs.

In a multipair thermocouple extension wire, adjacent pairs can pick up noise from a pulsating signal. This can be minimized by shielding the individual pairs.

Common mode noise will be generated if a grounded thermocouple is connected to a grounded instrument. This can be minimized by grounding the thermocouple and shield as close as possible to the measuring point.

## Thermocouple Design

The thermocouple used in an application should be selected specifically for the application.

### Size

The temperature sensed will be the average temperature across the length of the sensor.

### Shape

The shape must conform to the shape of the surface if the thermocouple is measuring surface temperatures.

### Response

The response time of a thermocouple is mass dependent. Therefore the size of the thermocouple must be small in relation to the object being measured. The response time should be approximately 5 times shorter than the fastest rate of temperature change to be monitored.

### Heat Conduction

Thermocouple extension wires can conduct heat into or out of the thermocouple. The wire must be insulated from the environment if this can occur.

### Sensor Position

The thermocouple measures the temperature of the object it is touching or the environment in which it is installed. Therefore the thermocouple must be positioned very carefully to insure that the temperature is being sensed at the correct point.

## Thermocouple Types and Descriptions

The DTS family of Temperature Scanners will accept inputs from Type E, J, K, N, R, S, and T Thermocouples. The accuracy of the measurement will depend upon the type of thermocouple and the quality of the extension wire used for the measurement.

### Type B

|              |  |
|--------------|--|
| Positive leg | 70% platinum, 30% rhodium  |
| Negative leg | 94% platinum, 6% rhodium   |
| Range        | 0 to 1800 °C   |
| Usable range | 400 to 1704 °C   |
| Notes        | Easily contaminated and damaged by reducing atmospheres. This thermocouple should be protected with a gas tight ceramic tube, a secondary tube of porcelain and a silicon carbide or metal outer tube. |

### Type E - Chromel Constantan

|              |  |
|--------------|--|
| Positive leg | 90% nickel, 10% chromium   |
| Negative leg | 43% nickel, 57% copper   |
| Range        | -270 to 1000 °C  |
| Usable range | 0 to 900 °C  |
| Notes        | Highest EMF output per degree of all recognized thermocouples. Has similar drift between 316 and 593 °C as a Type K thermocouple |

|                            |  |
|----------------------------|--|
| Type J - Iron Constantan   |  |
| Positive leg               | 100% iron  |
| Negative leg               | 43% nickel, 57% copper   |
| Range                      | -210 to 1200 °C  |
| Usable range               | 0 to 816 °C  |
| Notes                      | Not susceptible to aging from 371 to 538 °C. Very stable, should be used with a 96% pure MgO insulation and stainless steel sheath to prevent corrosion of the iron lead. Most commonly used thermocouple. |
| Type K - Chromel Alumel    |  |
| Positive leg               | 90% nickel, 10% chromium   |
| Negative leg               | 95% nickel, 2% aluminum, 2% manganese, 1% silicon  |
| Range                      | -270 to 1372 °C  |
| Usable range               | -36 to 1260 °C   |
| Notes                      | Not recommended from 316 to 593 °C because of aging that can cause drift rates of 2 °C in a few hours. Best used when corrosion may be a problem.  |
| Type N                     |  |
| Positive leg               | 14% chromium, 1.4% silicon, 84.6% nickel   |
| Negative leg               | 95.6% nickel, 4.4% silicon   |
| Range                      | -270 to 1372 °C  |
| Usable range               | 0 to 1260 °C   |
| Notes                      | Less aging from 316 to 593 °C than a Type K thermocouple.  |
| Type R                     |  |
| Positive leg               | 87% platinum, 13% rhodium  |
| Negative leg               | 100% platinum  |
| Range                      | -50 to 1767 °C   |
| Usable range               | 0 to 1482 °C   |
| Notes                      | Has a higher output than Type S thermocouples. Easily contaminated. This thermocouple should be protected by compacted mineral insulation and a metal outer sheath.  |
| Type S                     |  |
| Positive leg               | 90% platinum, 10% rhodium  |
| Negative leg               | 100% platinum  |
| Range                      | -50 to 1767 °C   |
| Usable range               | 0 to 1482 °C   |
| Notes                      | Easily contaminated. This thermocouple should be protected with a gas tight ceramic tube, a secondary tube of porcelain and a silicon carbide or metal outer tube.   |
| Type T - Copper Constantan |  |
| Positive leg               | Pure copper  |
| Negative leg               | 43% nickel, 57% copper   |
| Range                      | -270 to 400 °C   |
| Usable range               | -262 to 350 °C   |
| Notes                      | Good for low temperature and cryogenic applications  |

## International Thermocouple and Extension Wire Color Codes

| Country                               | USA                    | USA                     | United Kingdom          | United Kingdom            | Germany               | Japan                  | France                     |
|---------------------------------------|------------------------|-------------------------|-------------------------|---------------------------|-----------------------|------------------------|----------------------------|
| Standard                              | ANSI MC96.1 T/C        | ANSI MC96.1 Extension   | BS 1843                 | BS 4937                   | DIN 43714             | JIS C1610-1981         | NFE C42-323                |
| B Overall<br>B Positive<br>B Negative | -----                  | Grey<br>Grey<br>Red     | -----                   | -----                     | Grey<br>Red<br>Grey   | Grey<br>Red<br>Grey    | -----                      |
| E Overall<br>E Positive<br>E Negative | Brown<br>Purple<br>Red | Purple<br>Purple<br>Red | Brown<br>Brown<br>Blue  | Brown<br>Brown<br>Blue    | Black<br>Red<br>Black | Purple<br>Red<br>White | -----                      |
| J Overall<br>J Positive<br>J Negative | Brown<br>White<br>Red  | Black<br>White<br>Red   | Black<br>Yellow<br>Blue | Black<br>Black<br>White   | Blue<br>Red<br>Blue   | Yellow<br>Red<br>White | Black<br>Yellow<br>Black   |
| K Overall<br>K Positive<br>K Negative | Brown<br>Yellow<br>Red | Yellow<br>Yellow<br>Red | Red<br>Brown<br>Blue    | Green<br>Green<br>White   | Green<br>Red<br>Green | Blue<br>Red<br>White   | Yellow<br>Yellow<br>Purple |
| N Overall<br>N Positive<br>N Negative | Brown<br>Orange<br>Red | Orange<br>Orange<br>Red | -----                   | -----                     | -----                 | -----                  | -----                      |
| R Overall<br>R Positive<br>R Negative | -----                  | Green<br>Black<br>Red   | Green<br>White<br>Blue  | Orange<br>Orange<br>White | White<br>Red<br>White | Black<br>Red<br>White  | Green<br>Yellow<br>Green   |
| S Overall<br>S Positive<br>S Negative | -----                  | Green<br>Black<br>Red   | Green<br>White<br>Blue  | Orange<br>Orange<br>White | White<br>Red<br>White | Black<br>Red<br>White  | Green<br>Yellow<br>Green   |
| T Overall<br>T Positive<br>T Negative | Brown<br>Blue<br>Red   | Blue<br>Blue<br>Red     | Blue<br>White<br>Blue   | Brown<br>Brown<br>White   | Brown<br>Red<br>Brown | Brown<br>Red<br>White  | Blue<br>Yellow<br>Blue     |

## Appendix C - DTS3250 Error List

### Bootup/Initialization Errors

A/D 2 timeout error channel %ld RTD  
A/D 2 verify error channel %ld RTD  
A/D Board version  
A/D F/W version not 1, 2 or 3, Board %ld Fw %ld Hw %l  
A/D F/W version not all the same  
A/D H/W version not 9, Board %ld Fw %ld Hw %ld  
A/D timeout error channel %ld RTD  
A/D timeout error channel %ld  
A/D verify error channel %ld RTD  
A/D verify error channel %ld  
Board index not between 1 and %ld  
End board not between 1 and %ld  
End channel invalid  
End channel less than start channel  
End channel not between 1 and %ld  
End channel out of range  
Hardware version is not 9  
FifoLevel frames not between 1 and 480  
FifoLevel frames value not valid

All of these errors are fatal errors that indicate a serious hardware problem. They may only be viewed on the serial connection during bootup. If any of these errors are indicated, the module must be returned to the Scanivalve factory for repairs.

### Configuration Variable Errors

ARPC Board missing  
ARPC board not found  
ARPC Board out of range  
ARPC Board value not valid  
The board value was not entered, less than 1, greater than the maximum number of boards, or not numeric  
ARPC Reference temperature missing  
ARPC Reference temperature value not valid  
The RTD reference temperature was not entered, or is not a numeric value  
ARPC value not found  
ARPC value not valid  
The board value was not entered, less than 1, greater than the maximum number of boards, or not numeric  
ARPCON value not found  
ARPCON value not valid  
The value was not entered, or not 0 or 1  
AUTOCON value not found  
AUTOCON value not valid  
The value for AUTOCON was not entered, or not 0 or 1.  
Average value above range  
The value entered was greater than 240  
Average value below range  
The value entered was less than 1

**AVG value not found**

**AVG value not valid**

The value was not entered, negative or not numeric

**BIN value not found**

**BIN value not valid**

The value was not entered, or not 0 or 1

**CALAVG value not between 1 and 64**

The value is too high or too low

**CALAVG value not found**

**CALAVG value not valid**

The value was not entered or not numeric

**Calculated period value above range for 16 channel unit**

The value is greater than 262144  $\mu$ sec

**Calculated period value above range for 32 channel unit**

The value is greater than 524288  $\mu$ sec

**Calculated period value above range for 64 channel unit**

The value is greater than 1048576  $\mu$ sec

**Calculated period value below range**

The value is less than 781  $\mu$ sec

**Calculated period value may be too fast for some applications**

Refer to software documentation

**Channel index not between 1 and %ld**

**Channel out of range**

The PT Channel index entered was less than 1 or greater than 7.

**CHANNEL value not between 1 and %ld**

**CHANNEL value not found**

**CHANNEL value not valid**

The Channel number entered was less than 1, greater than max channels, or not numeric.

**COUNTS value not found**

The COUNTS value was not entered or not numeric

**DEF channel not between 1 to max channels**

The value is less than 1 or more than 16, 32, or 64

**DEF channel not found**

**DEF channel not valid**

The value was not entered, negative or not numeric

**ECHO value not found**

**ECHO value not valid**

The value was not entered or not 0 or 1

**FORMAT value not found**

**FORMAT value not valid**

The value was not entered or not 0 or 1

**FPS value not found**

**FPS value not valid**

The value was not entered, less than 0, or greater than 4294967295

**Gain CHANNEL value not between 1 and %ld**

**Gain channel value not found**

**Gain channel value not valid**

The channel number entered was less than 1, greater than the maximum channel number for this module, or not numeric.

**Gain value not found**

**Gain value not valid**

The gain value was not entered or not numeric.

**HOST IP address value not valid**

The IP address entered is not a valid IP address

**HOST server port value not valid**

The port number entered is not a valid port number

**HOST value not found**

No modifiers were entered for the HOST variable

**Invalid list parameter**

The list parameter entered is not defined. Refer to the Software Specification.

**Invalid set parameter**

The SET parameter entered is not a valid configuration variable name

**Invalid channel value**

The channel number entered is less than 1 or greater than the maximum channel number for this module.

**IPO Channel out of range**

The channel number entered is less than 1 or greater than the maximum channel number for this module.

**IPO end channel invalid**

The channel number entered is greater than the maximum channel number for this module.

**IPO end channel less than start channel**

The channel number entered is less than the start number.

**IPO end channel out of range**

The channel number entered is less than 1, or greater than the maximum channel number for this module, or not a numeric value.

**IPO Invalid start channel value**

**IPO Start channel not present**

The channel number entered is less than 1 or not a numeric value.

**IPO Exceeded max iterations**

The IPO routine could not calculate a zero offset correction

**LABEL channel not between 1 and %ld**

**LABEL channel value not found**

The channel number entered was less than 1, greater than the maximum channel number, or not entered.

**LABEL value not valid**

The channel number entered was not numeric.

**Limit channel value not between 0 and %ld**

**Limit channel value not found**

The channel number entered was less than 1, greater than the maximum channel number, or not entered

**Limit channel value not valid**

The channel number entered was not numeric

**Limit enable value not found**

**Limit enable value not valid**

The value was not entered, or was not 0 or 1.

**List A task spawn failed**

Fatal error - coefficients could not be found

**List DEF channel not found**

**List DEF channel value not valid**

The channel number was not entered or not numeric.

**List DEF channel out of range**

The channel number entered was less than 1 or greater than the maximum channel number.

**List P BOARD value not between 1 and %ld**

The value entered was 0 or greater than the number of boards installed.

**List P BOARD value not valid**

The board number was not entered or not numeric.

**List P CHANNEL value not between 1 and %ld**

The value entered was 0 or greater than the number of boards installed.

**List P CHANNEL value not valid**

The board number was not entered or not numeric

**List P CHANNEL value not found**

The board number was not entered or not numeric

**List P TEMP value not between 0 and %ld**

**List P TEMP value not valid**

The temperature, or temperature range entered was less than 0, greater than the maximum module temp, or not numeric.

**List value not found**

The list command type was not specified

**MAXDELTA value not found**

**MAXDELTA value not valid**

The value was not entered or not numeric

**Missing R or T parameter from LIST P**

The List P command must include a R or T modifier.

**Model value not found**

**Model value not valid**

The model number and channel value was not entered or is not a valid model number.

**Number of boards is not 1, 2, or 4**

These are the only valid values for any board term.

**NUMCOEF value not between 1 and 3**

**NUMCOEF value not found**

**NUMCOEF value not valid**

The NUMCOEF value entered was less than 1, greater than 3 or not entered.

**NUMPTS value not between 1 and 8**

**NUMPTS value not found**

**NUMPTS value not valid**

The NUMPTS value entered was less than 1, greater than 8 or not entered.

**NUMTEMP value not between 0 and 8**

**NUMTEMP value not found**

**NUMTEMP value not valid**

The NUMTEMP value entered was less than 1, greater than 3 or not entered.

**Offset CHANNEL value not between 1 and %ld**

**Offset channel value not found**

**Offset channel value not valid**

The CHANNEL number entered was less than 1, greater than max channels, or not entered.

**Offset value not found**

**Offset value not valid**

The Offset gain value was not entered, or not numeric.

**Period value above range for 16 channel unit**

The value is greater than 262144  $\mu$ sec

**Period value above range for 32 channel unit**

The value is greater than 524288  $\mu$ sec



**Period value above range for 64 channel unit**

The value is greater than 1048576  $\mu$ sec

**Period value below range**

The value is less than 781  $\mu$ sec

**Period value may be too fast for some applications**

Refer to software documentation

**Period value not found**

**Period value not valid**

The value was not entered, negative or not numeric

**PORT value not found**

**PORT value not valid**

The value entered was not a valid port number or not numeric.

**PT index invalid**

**PT index not present**

The value was not entered, negative or not numeric

**PT Volts missing**

The value was not entered.

**QPKTS value not found**

**QPKTS value not valid**

The value was not entered, negative or not numeric

**Range Temp Hi value not found**

**Range Temp Hi value not valid**

The value was not entered, negative or not numeric

**Range Temp Lo value not found**

**Range Temp Lo value not valid**

The value was not entered, negative or not numeric

**Range Volt Hi value not found**

**Range Volt Hi value not valid**

The value was not entered, negative or not numeric

**Range Volt Lo value not found**

**Range Volt Lo value not valid**

The value was not entered, negative or not numeric

**Rate value is too slow**

The value is less than 0.01samples/channel/sec

**Rate value not found**

**Rate value not valid**

The value was not entered, negative or not numeric

**RNUMCOEF value not between 1 and 7**

**RNUMCOEF value not found**

**RNUMCOEF value not valid**

The value entered was less than 1, greater than 7, not numeric, or not entered

**RNUMPTS value not between 1 and 8**

**RNUMPTS value not found**

**RNUMPTS value not valid**

The value entered was less than 1, greater than 8, not numeric, or not entered

**RPC Board missing**

**RPC board number not found**

**RPC board number not valid**

**RPC board number out of range**

The board value entered in the RPC command was omitted, greater than the number of boards in the module, less than one, or not numeric

**RPC board number value not valid**

**RPC Board out of range**

**RPC Board value not valid**

The board value entered in the List RPC command was omitted, greater than the number of boards in the module, less than one, or not numeric

**RPC index not present**

**RPC INDEX value not found**

The RPC Index value was not entered or not numeric.

**RPC INDEX value not between 0 and 7**

**RPC INDEX value not valid**

The RPC index value was negative, greater than 7, or not numeric

**RPC Volts missing**

**RPC VOLTS value not found**

The RPC volts value was not entered or not in the correct format.

**RPC COUNTS value not found**

**RPC COUNTS value not valid**

The RPC counts value was not entered or not numeric

**RTD A term value not found**

The A term was not entered or not in the correct format

**RTD B term value not found**

The B term was not entered or not in the correct format

**RTD Channel board number out of range**

The channel/board number must be 1 to 64 for a thermocouple channel, or 1 to 4 for an RTD. The 1 to 4 in the RTD indicates the board number. The board number cannot be greater than the number of boards in the module.

**RTD channel out of range**

**RTD channel value not found**

**RTD channel value not valid**

The value entered was less than 1, greater than the maximum number of channels in the module, not entered or not numeric.

**RTD Ohms value not found**

The ohms value was not entered

**RTD Point index value not found**

**RTD Point index value not valid**

The value entered must be 0 to 7

**RTD MAXSLEW value not found**

**RTD MAXSLEW value not valid**

The value entered was less than 0, greater than 32000, or not numeric.

**RTDX channel out of range**

**RTDX channel value not found**

**RTDX channel value not valid**

The RTDX channel value was less than 1, greater than the maximum number of RTD channels, not numeric, or not entered.

**RTDX value not found**

**RTDX value not valid**

The value for RTDX was not entered or not numeric.

**SerNum value not found**

**SerNum value not valid**

The value was not entered or not numeric

**TC MAXSLEW value not found**

**TC MAXSLEW value not valid**

The value entered was less than 0, greater than 3000000, or not numeric.

**Temperature index is missing**

**Temperature index not between 0 and %ld**

**Temperature index value not valid**

The temperature index value entered in the PT command must be between 1 and the value of NUMTEMPS

**Temperature value not valid**

**Temperature is missing**

The temperature value entered in the PT T/R command was omitted or not numeric.

**Temperature is not between -10.0 and 75**

The temperature value entered in the Set PT T/R command was less than -10 or more than 75 degrees F.

**TIME value not found**

**TIME value not valid**

The value for TIME must be a 0, 1, or 2

**TITLE1 value not valid**

**TITLE2 value not valid**

The TITLE values may not exceed 255 ASCII characters

**Type channel value not between 0 and %ld**

**Type channel value not found**

**Type channel value not valid**

The value entered was not between 1 and maximum channel, not entered, or not numeric

**Type shield connect switch not 0 or 1**

The value was not entered, not 0 or 1, or not numeric

**Type value not found**

**Type value not supported**

**Type value not valid**

The T/C type was not entered or not a supported type.

**Units value not found**

**Units value not valid**

The UNITS value was not entered or not a supported type

**UPLOAD <S or C> value not found**

The UPLOAD type must be S or C

**UPLOAD file name not found**

The file name or path entered is not valid

**UpLoad task spawn failed**

Fatal Error

**Voltage index is missing**

**Voltage index not between 0 and %ld**

**Voltage index value not valid**

The SET PT T/R voltage index entered was less than 0, more than NUMPTS, not entered, or not numeric

**Voltage is missing**

**Voltage is not between -25mv and 100mv**

The SET PT T voltage entered was less than -25 mv, more than 100 mv, or not entered.

**Voltage is not between 75mv and 150mv**

**Voltage value not valid**

The SET PT R voltage entered was less than 75 mv, more than 150 mv, not entered, or not numeric.

**VOLTS value not found**

The SET PT voltage was not entered, or not numeric

**XSCANTRIG value not found**

**XSCANTRIG value not valid**

The value was not entered, negative or not numeric

**XSCANTRIG value out of range**

The value was not between 1 and 15

## **Command Errors**

**AUTOSTATUS value not found**

**AUTOSTATUS value not valid**

The value for AUTOSTATUS was not entered, or not 0 or 1.

**Cannot open file %s**

The file name or path entered is not valid

**Cal data error**

Fatal error - No raw data were received from a PT command. The calibration failed.

**HOSTCMD value not valid**

The ASCII command string was not entered or is not a valid ASCII command string

**Invalid command**

The command entered was not a valid DTS command

**Mode ready, invalid command**

The command entered was not a valid DTS command

**Invalid range of board**

The board number entered was greater than the number of board in the module.

**Invalid range of channel**

The channel entered was greater than the maximum number of channels in the module

**Invalid single channel**

The channel number entered is not supported in this module

**Invalid single board number**

The RTD number in a PT T/R command was not entered, less than 0, or greater than the number of RTDs

**Max errors exceeded**

The error buffer is full. More than 15 errors have been logged.

**Open T/C for channel %ld**

**Otc data error**

The OTC command has detected a possible open channel. Reboot to clear the error

**RawData frames value not valid**

**RCal data error**

Data returned from a PT command were faulty. The calibration failed.

**Set value not found**

A SET command was issued with no variable or modifiers

**Start board not between 1 and %ld**

The start board value must be between 1 and the maximum number of boards in the module.

**Start channel not between 1 and %ld**

The start channel value must be between 1 and the maximum number of channels in the module.

## **Communication/Hardware Errors**

**Alignment error**

**Alignment rb%lu f%1IX lbx%1IX lb%1IX tx%1IX t%1IX cx%1IX c%1IX**

Fatal Error - Reboot module

**JTAG <9572, 95288, DTS95288> value not found**

**JTAG file name not found**

**Jtag task spawn failed**

**JTAG type must be 9572, 95288, DTS95288, A2DMUX, or A2Dn**

Fatal errors - Reboot, if error recurs, the module must be returned for repair.

**Closing slave socket with read error**

Fatal error - reboot

**Could not bind a socket**

**Could not bind a UDP socket**

**Could not connect to server**

The path to the host is not valid or the Ethernet connection is open.

**Could not create a socket**

**Could not create a UDP socket**

**Could not create client socket**

Operating system fatal error - reboot module.

**Could not open flash file for read config variables**

**Could not open flash file for write**

**Could not open flash file for write config variables**

**Could not open remote config file**

**Could not open system file**

Fatal errors - Reboot, if error recurs, the module must be returned for repair.

**Could not spawn a load rtd task**

**Could not spawn adcal and load rtd task**

**Could not spawn Arpc task**

**Could not spawn cal task**

**Could not spawn ipo task**

**Could not spawn ListP task**

**Could not spawn ListPTemp task**

**Could not spawn ListPTemp task**

**Could not spawn otc task**

**Could not spawn RPC cal task**

**Could not spawn scan out task**

**Could not spawn scan task**

**Could not spawn Tcp Server**

**Could not spawn Type task**

**Could not spawn Udp Id Server**

**Could not spawn Udp Server**

**Could not spawn Web Server**

**Could not create output message queue**

**Could not listen on a socket**

**Could not open binary socket**

**Save task spawn failed**

**Slave task spawn failed**

Fatal errors - attempt reboot - if errors recur the module must be returned for repair

**Data buffer overflow**

Fatal Error - reboot

**Data overflows allocated MAX\_LEN buffer size**

Fatal error - attempt reboot - if errors recur the module must be returned for repair

**LoadRtd data error**

**MadCal A/D command write error channel %ld**

**MadCal A/D offset read error channel %ld**

**MadCal A/D span read error channel %ld**

**MadCal A/D span verify error channel %ld**

**MadCal A/D verify offset error channel %ld**

Fatal errors - attempt reboot - if errors recur the module must be returned for repair

**Read address invalid**

**Read address not present**

**Read bad offset, retry %ld A %ld C %ld O %ld**

**Read bad span, retry %ld A %ld C %ld S %ld**

**Read repeat not between 1 and 200**

**ReadMadCal A/D offset read error channel %ld**

**ReadMadCal A/D span read error channel %ld**

These errors indicate a bad A/D was detected during the execution of an ADCAL command.

Repeat the command, if the errors recur, the module must be returned for repair.

**Receive message queue**

**Send message queue**

**Send queue is full**

These errors indicate a network blockage.

**TCP OUT Mismatch Req %d Act %ld**

The host did not receive the number of bytes requested. Req is the bytes requested, Act is the number received. This could be caused by a firewall.

**Timeout Ad hdwResetAd**

Fatal error - attempt reboot - if errors recur the module must be returned for repair

## Appendix D - Software Change Log

- Version 3.00 - Released October 2004  
Completely revised software for 16, 32, and 64 channel modules.  
Supports all 32 and 64 channel modules  
Supports 16 channel modules Serial Number 1100 and higher
- Version 3.01 - Released February 2005  
Corrected a bug in RTD\_MAX\_SLEW for RTD's 3, 4, 5, 6, 7 and 8
- Version 3.02 - Released May 2006  
Added Network Identification  
Listen on port 7000 for 255.255.255.255  
Respond on port 7001 with <IP Address>, <Model/Ch>, <Serial Number>  
Added Network Identification Group (ID)  
IP Address  
Model  
Sernum  
Ver  
Def x
- Version 3.03 - Not Released
- Version 3.04 - Not released
- Version 3.05 - Released January 2007  
Removed Def x from the Network Identification Group (ID)  
Created a new group: Channel Definition Group (Group DEF) with DEF as the only variable  
Increased the DEF variable definition from 64 bytes per channel to 2048 bytes per channel  
Added a new command: List Channel Definitions  
LIST DEF <channel>  
Added the command: Ice Point Offset Adjustment  
IPO <start channel> <end channel>  
Added an abbreviated syntax for AUTOSTATUS. Autostatus can be enabled or disabled by either the full command: AUTOSTATUS <enable>, or the abbreviated command: AS <enable>  
Corrected a bug in the ADCAL function that set the offset calculated during an ADCAL to four times the correct value.  
Corrected a bug that blocked the output of RTD data from RTDs 5, 6, 7, and 8 in TCP binary configuration.  
Modified the following variable defaults  
NUMPORTS 8  
CALAVG 8  
RNUMCOEF 5  
RNUMPTS 8  
TYPE n K 0  
Disabled the Nagle Algorithm in TCP and UDP data transmission. This will guarantee one frame per packet in either data transmission format.  
Added ARPCON variable to the UTR Calibration Variable Group. This variable enables the ARPC correction.  
Added ARPC variable to the UTR Calibration Variable Group. This variable is a correction factor to the Calendar Van-Dusen conversion.  
Added a scan trigger divider. Limited to values from 1 to 15.  
Added the command: ARPC to calculate the ARPC correction for each board.

- Version 3.06 - Not Released
- Version 3.07 - Released August 2010  
Software changes to permit use of additional A/D board versions. These modifications are transparent to a user.
- Version 4.00 - Not Released
- Version 4.01 - Released October 2007  
Added NUMTEMPS to Calibration Variable Group (Group C)  
Added commands to be active only if NUMTEMPS is set to 1 or greater  
PT  
LIST P  
Added variable to be active only if NUMTEMPS is set to 1 or greater.  
PT  
Removed temperature data test limits -200 to +1800 degrees C  
Added temperature data test limits for NIST range of each TC type. A range error will result in a code 5000 or 6000 in the channel status of the output packet.  
Added error if A/D Xilinx versions for each A/D board are different.
- Version 4.02 - Released October 2007  
Removed NUMTEMP optional reference temperature parameter.  
Removed ability of List P to list both T and R data  
Range check added to A/D span and offset values  
Adjusted delay time for Read/Write Retry.
- Version 4.03 - Released November 2007  
Modified display to show RTD temps in degrees when NUMTEMPS is greater than 0 and Units is set to Volts.
- Version 4.04 - Released November 2007  
Changed default value of NUMTEMPS from 8 to 0. This will prevent loss of calibration coefficients if the firmware is upgraded in the field.
- Version 4.05 - Released November 2007  
Changed oversampling rate of the RTD A/Ds to 8X from 5X.
- Version 4.06 - Released January 2008  
Corrected an index problem in the PT R command  
Corrected a Range Input problem in the PT R command  
Corrected a Range Input problem in the PT T command  
Corrected an overwrite problem in the PT T command  
Corrected a problem with the List PT R 0 command.
- Version 4.07 - Released February 2008  
Corrected the error code output for the PT Command. An error will be generated if the PT command is below -10 degrees C
- Version 4.08 - Not released



- Version 4.09 - Released June 2008  
Corrected a bug in the setting of Max and Min counts when NUMTEMPS is non-zero.  
Added debug command, RADCAL, to read A/D offsets and span register. Data from this read are output to the back door. This command is not for customer use.  
Improved the algorithm to set PERIOD in the A/Ds  
Changed A/D multiplier to 5  
Changed RTD multiplier to 5  
Added a re-sync of the RTD A/D when PERIOD is set
- Version 4.10 - Not released
- Version 4.11 - Released July 2008  
Corrected a bug in the LIST P T <chan> <temp> command  
Added a range check, 0 or 1, to the TYPE configuration variable  
Added a limit check, 31 characters, to LABEL  
Corrected a bug in the flash write routine when a STATUS command is received before the write is completed.  
Added an error check to the flash write
- Version 4.12 - Released May 2009  
Modified Register setup during the boot process. This has no effect on the commands or variables.
- Version 4.13 - Released November 2009  
Removed high limit check on period and rate.  
Made several changes to improve software performance. These changes do not affect the documentation.
- Version 4.14 - Released November 2010  
Added a Noise test. This test is only used during circuit board tests
- Version 4.15 - Released November 2011
- Version 4.16 - Released May 2013  
Updated to check for and support A/D firmware version 4 as well as expected vs actual RTD handling  
Changed RTD registry low byte setting to FF by default
- Version 4.17 - Released November 2013  
Resolved a bug that prevented the RTD\_MAX\_SLEW filtering from being applied to RTDs 5, 6, 7 & 8.  
Changed the operation of the RESTART command to restart the hardware as well as the software.
- Version 4.18 - Released February 2014  
Removed the modification to the RESTART command implemented in V4.17. The changes made were not functional on all processor boards and could result in a hardware lockup requiring physical power cycle for recovery.
- Version 4.19 - Released August 2014  
Removed the RTD registry default setting of FF as it caused inconsistent RTD readings at with some PERIOD settings. Removed unnecessary debug data output with NUMTEMPS set greater than 0.