

# ENETCPM

## Ethernet Control Pressure Module

### Instruction and Service Manual

Software Version 1.03

06/2007

---

1722 North Madson Street  
Liberty Lake, WA 99019

Tel: (800) 935-5151

(509) 891-9970

Fax: (509) 891-9481

web site: [www.scanivalve.com](http://www.scanivalve.com)

e-mail: [scanco@scanivalve.com](mailto:scanco@scanivalve.com)

***Scanivalve Corp.***

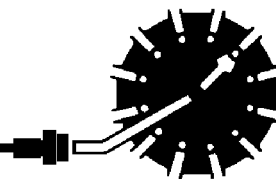

# Table of Contents

Specifications.....	1
General Description.....	2
ENETCPM Network/Firmware.....	2
ENETCPM Dimensions and Configuration.....	3
Power Requirements.....	4
Trigger Requirements.....	5
Hardware Trigger.....	5
Software Trigger.....	5
RS 232 Communications.....	6
Ethernet Connections.....	7
10Base-T.....	7
Digital Outputs.....	8
ENETCPM Control and Configuration.....	9
ENETCPM Commands.....	9
COMMAND LIST.....	10
AUTOSTATUS.....	10
CLEAR.....	10
DOUT.....	11
ERROR.....	11
LIST ALL.....	12
LIST IDENTIFICATION.....	13
LIST NAME SETTINGS.....	14
LIST SEQUENCE STEPS.....	14
LIST SWITCH STATES.....	15
SAVE.....	15
SET.....	16
START.....	16
STATUS.....	16
STOP.....	16
UPLOAD.....	17
VERSION.....	17
CONFIGURATION VARIABLES.....	18
LAST.....	18
PORT.....	18
SEQ.....	18
STATE.....	19
STEP.....	19
TITLE1.....	19
TITLE2.....	19

ENETCPM Packet Definitions.....	20
ENETCPM to HOST.....	20
ASCII Packet .....	20
Network Protocols Supported.....	20
ENETCPM Recommended Operation.....	20
ENETCPM Web Server.....	21
Web Server Operation.....	22
Home.....	23
Password.....	24
Links.....	24
Help.....	24
Config.....	25
General.....	25
State.....	26
Sequence.....	27
Operate.....	28
Test.....	29
Status.....	30
Support.....	31
Closing the Web Browser.....	31
Host Web Browser Setup.....	32
Internet Explorer.....	32
Netscape Navigator.....	34
ENETCPM Boot Parameter Modification.....	35
Boot parameters and their functions.....	37
ENETCPM Operating System Upload.....	38
Appendix A - WarFTP Server.....	39
Installation.....	39
Configuration and Setup.....	41
Appendix B - Accessories.....	46
Power Supply - PDM 1000.....	46
Power Supply - PDM 3200.....	47
Appendix C - Change Log.....	48

## Figures and Illustrations

Figure 1 - Typical Pressure/Temperature Scanning System. ....	2
Figure 2 - ENETCPM Dimensions.....	3
Figure 3 - Digital Sensor Array Power Wiring. ....	4
Figure 4 - Trigger wiring.....	5
Figure 5 - RS232/ External Trigger Test Cable.....	6
Figure 6 - ENETCPM 10Base-T cables.....	7
Figure 7 - Digital Output Wiring.....	8

## Command List

AUTOSTATUS <enable>.....	10
DOUT <discrete channel><status>.....	11
LIST A. ....	12
LIST I. ....	13
LIST SE. ....	14
LIST ST <sequence ID>. ....	14
LIST T <channel>. ....	15
SAVE . ....	15
SET <name> <value>. ....	16
START <Sequence ID>.....	16
STATUS.....	16
STOP.....	16
UPLOAD <S or C><filepath\filename> . ....	17
VER . ....	17

## Configuration Variables

LAST <Sequence ID> <Step number> .....	18
PORT xxxx.....	18
SEQ <Sequence number> <Sequence name> .....	18
STATE <State number> <name> <switch state> .....	19
STEP <Sequence ID> <Step number> <State ID> <Delay> . ....	19
TITLE1 <title>.....	19
TITLE2 <title>.....	19

## Specifications

<b>Inputs:</b>	Clean dry air
ZOC22, ZOC23, and ZOC33	65 psi
DSA and other ZOC modules	
≤500 psi FS	90 psi
>500 psi FS	120 psi
<b>Outputs:</b>	
Pressure	Three discrete lines for control pressures to DSA and ZOC modules
Voltage	Five digital outputs to control valves or other switching devices.
<b>Operating Temperature:</b>	-30°C to 55°C
<b>Communication:</b>	Ethernet 10Base-T (standard) RS-232 (Configuration Only)
<b>Communication Protocol:</b>	TCP/IP or UDP
<b>Mating Connector Type:</b>	
Ethernet	Bendix PT06A-8-4S-SR, 4 pin female
Power	Bendix PTO6A-8-3S-SR, 3 pin female
Trigger/Configuration	Bendix JTO1RE8-6S-SR, 6 pin female
Digital Output	Bendix PT06A-12-10P-SR 10 pin female
<b>Power:</b>	24Vdc nominal (22 -26 Vdc) @ 12 VA with no external relays powered @ 30 VA with all external relays powered
<b>Weight:</b>	6.25 pounds(2.841 kg)
<b>CE Mark Standards:</b>	IEC 1000-4.2, 1000-4.3, 1000-4.5

## General Description

The Ethernet Control Pressure Module (ENETCPM) is designed to distribute pressures to DSA Ethernet Pressure Scanners, ZOC Pressure Scanners as control pressures to calibration valves. It may also be used to switch external solenoid valves or relays to control ancillary equipment for special applications.

## ENETCPM Network/Firmware

ENETCPM modules accept software commands via Ethernet only. The ENETCPM modules may be controlled with an external or software trigger.

Each ENETCPM module has a unique factory set 48 bit MAC address. When running TCP/IP protocol, the ENETCPM modules support ARP (Address Resolution Protocol) to enable the client/host to determine the relationship between the IP address and the Ethernet address. The IP address is user assignable.

All setup variables are configured through software by the user.

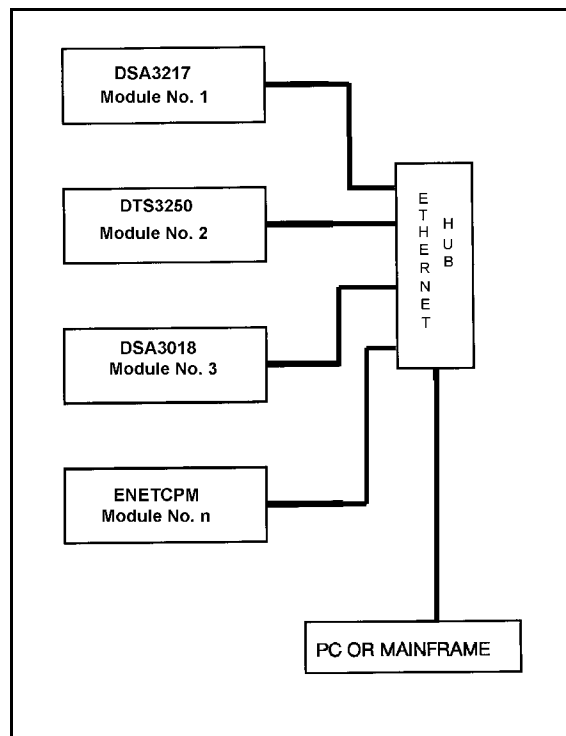

Figure 1 - Typical Pressure/Temperature Scanning System

# ENETCPM Dimensions and Configuration

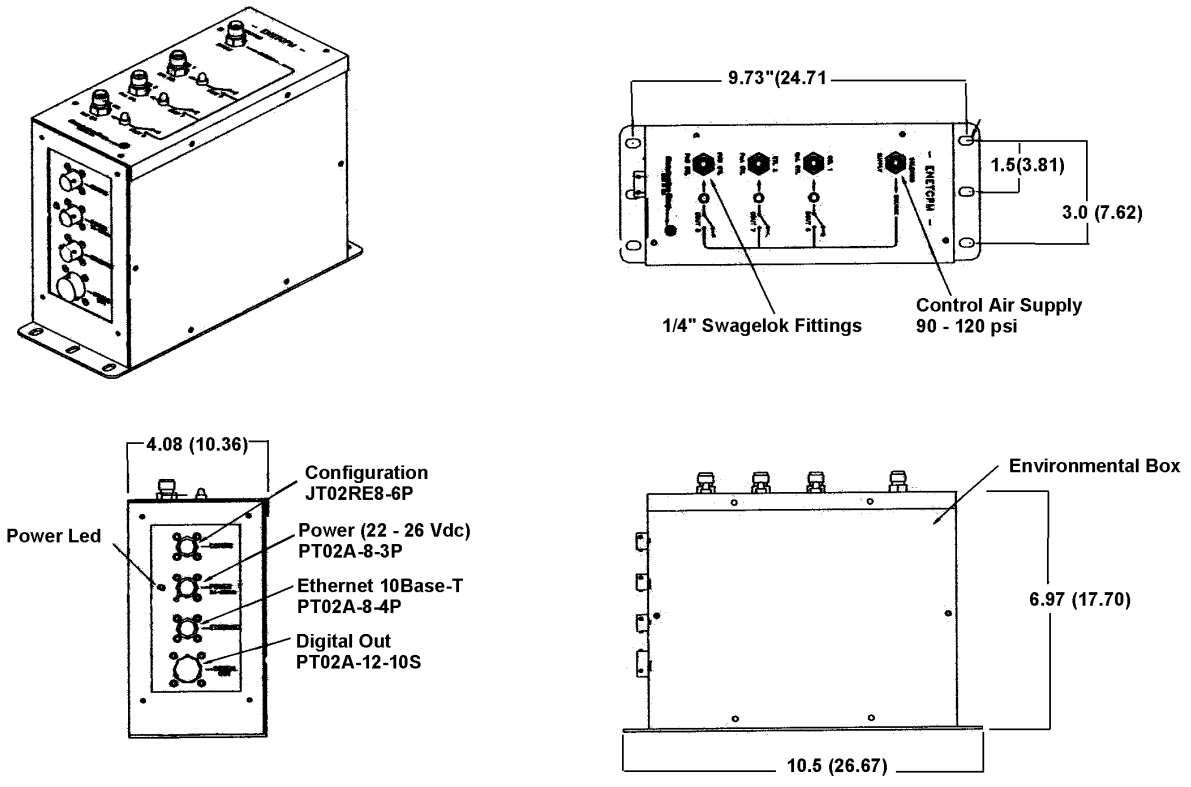

Figure 2 - ENETCPM Dimensions

## Power Requirements

The ENETCPM requires  $24 \pm 2.5$  Vdc at approximately . Power connections are made through a three pin connector located on the side of the module. The pinouts of the connector may be found in figure 3. The mating connector is a PT06A-8-3S-SR.

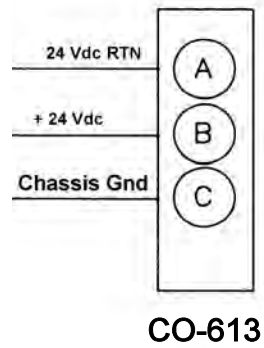

Figure 3 - Digital Sensor Array Power Wiring



# Trigger Requirements

## Hardware Trigger

The ENETCPM scan functions may be synchronized with other data acquisition devices by using the external trigger. The external trigger input is opto-isolated to prevent grounding problems. It is a TTL level, edge sensing device. It requires a minimum signal of 9Vdc @ 6.5 mA. It may accept voltages as high as 15 Vdc.

The external trigger will only be active if the ENETCPM XSCANTRIG variable is set to 1. When a SCAN command is issued by the Client/host, the module will enter the SCAN mode and wait for a trigger. An averaged frame of data will be output as soon as the minimum trigger edge level is achieved. Data will be output with each successive trigger pulse to the FPS variable (Frames per Scan) value or until a STOP command is issued.

ENETCPM Modules use a 6 pin connector for a combination Trigger and Serial Communications Interface. The wiring is shown in figure 4. The mating connector is a JT06RE8-6S-SR (Scanco Pn CO-737) .

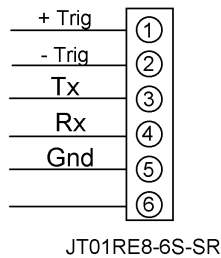

Figure 4 - Trigger wiring

## Software Trigger

The ENETCPM may also be triggered with a software trigger. The software trigger will only be active if the XSCANTRIG variable is set to 1. When a SCAN command is issued by the Client/host, the module will enter the SCAN mode and wait for a trigger. An averaged frame of data will be output as soon as the TRIG command or a <TAB> character (9 HEX or Control I) is received. Data will be output with each successive trigger command to the FPS variable (Frames per Scan) value or until a STOP command is issued.

# RS 232 Communications

Every ENETCPM Module has a RS 232 output. It is available at the Serial Communications/Trigger Connector. It is required to configure the module IP address, or upload operating system upgrades. The wiring of the RS 232 output is shown in figure 5.

The RS232 inputs and outputs are not opto-isolated. Therefore, the RS232 connection could cause ground loops if it is connected during data acquisitions. Because the RS232 connection is only used for initial configuration, there is no need to maintain the connection after that setup is completed unless the external trigger function will be used.

If the RS232 connection is part of a combination Serial/Trigger cable, the RS232 connection at the host computer should be disconnected during data operations to prevent problems.

A combination RS232 and External Trigger test cable(Scanco PN 155829) is available as an option. The cable is shown below along with a wiring diagram.

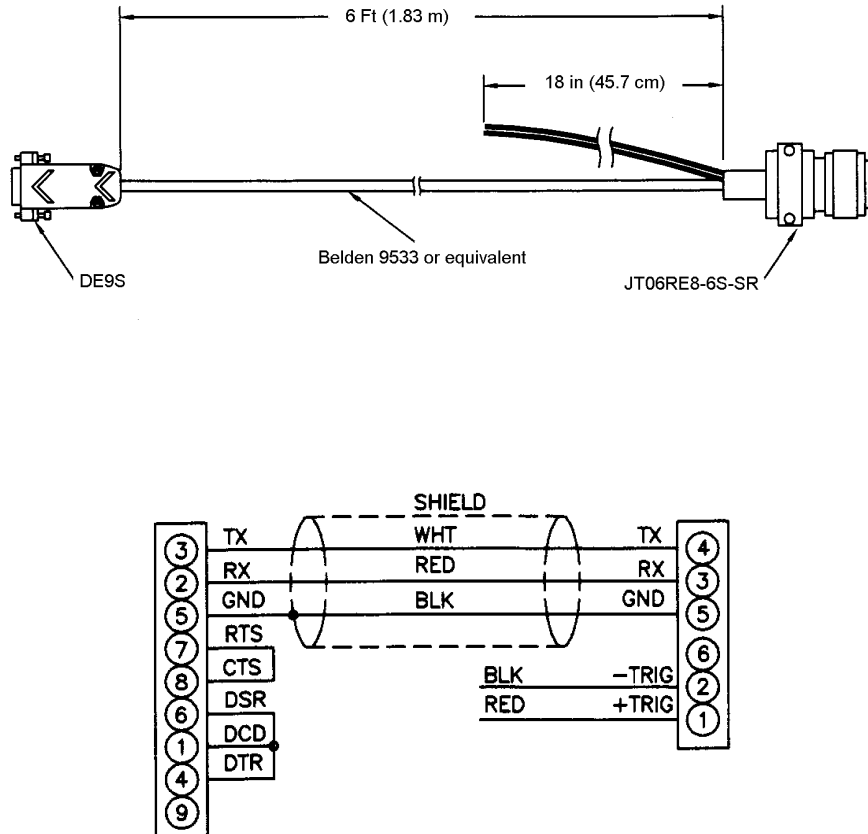

Figure 5 - RS232/ External Trigger Test Cable

# Ethernet Connections

The ENETCPM has provisions for 10Base-T Ethernet connections only. Ethernet 10Base-2 connections may be made with media converters.

## 10Base-T

The 10Base-T connection uses a Bendix connector at the module, which must be interfaced to the standard RJ-45 connector. A 10Base-T connection may be straight through (pin to pin) or crossover. A straight through cable must be used if the module is connected to a hub. Crossover connections are used if the module is connected directly to the host computer. It is recommended that Category Five cables be used. The maximum length for 10Base-T cables is 100 meters, but signal strength can be attenuated at this distance. A repeater is required for 10Base-T cable runs greater than 100 meters. Cables may be ordered from Scanivalve Corp. The pin to pin cable part number is 155820-01. The crossover cable part number is 155859-01. The cable length must be specified when the cable is ordered.

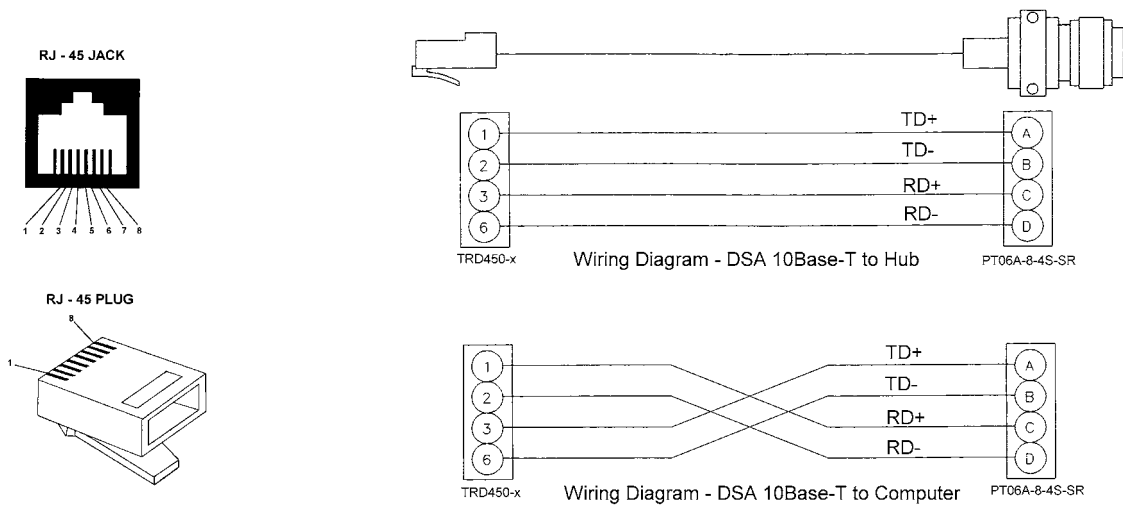

Figure 6 - ENETCPM 10Base-T cables

## Digital Outputs

Each ENETCPM has a Digital Output connector. A maximum of Five(5) Digital Outputs may be configured. Configuration information may be found in the Software Section of this manual

The Digital Outputs are powered by the DC Power voltage. It is recommended that the user supply be capable of providing +24 Vdc at 4 Amps. Each Digital Output is limited to 24 Vdc @ 500 mA maximum.

Figure 7 shows the wiring of the Digital Outputs.

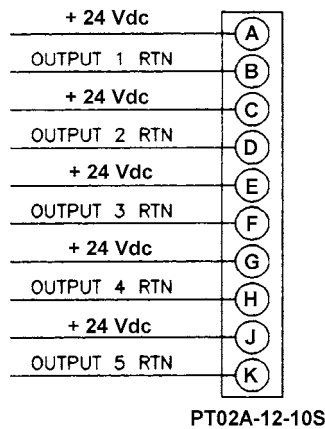

Figure 7 - Digital Output Wiring

## ENETCPM Control and Configuration

The operation of each ENETCPM is controlled by sending ASCII commands over the TelNet port(port 23) to units selected by network addressing. The ENETCPM returns any data or information over the network to the requesting client/host in ASCII format.

### ENETCPM Commands

The ENETCPM software runs as embedded software on the ENETCPM hardware. It performs the following general tasks:

1. Receive and execute commands from the Ethernet Link.
2. Allow the configuration to be saved through power down.
3. Output status, setup and configuration data over the Ethernet Link.
4. Set the ENETCPM Physical Ethernet Address(MAC Address).
5. Protocol to be TCP/IP.
6. Support the user in troubleshooting the ENETCPM hardware and system.

When operating in the ASCII mode or UDP, the ENETCPM is the client. In Binary or TCP mode, the ENETCPM is the Host.

When a ENETCPM module is in a "NOT READY" mode, all commands are disabled except STATUS and STOP.

TCP/IP does not guarantee that packet boundaries will be maintained between a Host and a ENETCPM module. Therefore, **ALL** commands from a Host **MUST** be terminated properly with one of four options. The ENETCPM will detect and adjust to the termination option being used by a Host.

The four options are:

- CR (ASCII 13)
- LF (ASCII 10)
- LF-CR (ASCII 10 - ASCII 13)
- CR-LF (ASCII 13 - ASCII 10)

The current ENETCPM RS232 interface is designed for initial boot configuration only.

# COMMAND LIST

COMMAND	<b>AUTOSTATUS</b>
COMMAND SYNTAX	<b>AUTOSTATUS &lt;enable&gt;</b>
ARGUMENTS	Enable - 0 or 1
DESCRIPTION	If autostatus enable is set to 1, the ENETCPM will automatically output the status of the ENETCPM whenever the status changes. When set to 0, status can only be determined by issuing a STATUS command. The condition at power up and after a reboot is AUTOSTATUS disabled.
RETURNS	<nl> <nl> - end of line.
EXAMPLES	To enable automatic output of the ENETCPM status, the following command would be issued: AUTOSTATUS 1 To disable automatic output of the ENETCPM status, the following command would be issued: AUTOSTATUS 0
NOTE	AUTOTATUS was not set up as a configuration variable that could be saved to prevent conditions where the ENETCPM would be talking on a network when it was not expected to be talking.
COMMAND SYNTAX	<b>CLEAR</b> <b>CLEAR&lt;CR&gt;</b>
ARGUMENTS	None
DESCRIPTION	Commands the DSM to clear any errors that have occurred. The errors are sent to the client in response to a ERROR command.
RETURNS	<nl> <nl> - end of line.
EXAMPLE	To clear any errors listed in the ERROR Buffer, the following command would be issued:  CLEAR <CR> The ERROR buffer will be cleared

**COMMAND**  
**SYNTAX**  
**ARGUMENTS**

**DOUT**  
**DOUT <discrete channel><status><CR>**  
 <discrete channel> - a Digital Output channel 1 through 8.  
 <status> - 1 = On  
           0 = Off

**DESCRIPTION**

Commands the Discrete Output channel on or off.

**RETURNS**

<n/><br>
 <n/><br> - end of line.

**EXAMPLE**

In this example, digital output channel 1 will be energized:

DOUT 1 1 <CR>

In this example, digital output channel 5 will be de-energized

DOUT 5 0 <CR>

**COMMAND**  
**SYNTAX**  
**ARGUMENTS**  
**DESCRIPTION**

**ERROR**  
**ERROR <CR>**  
 None

**DESCRIPTION**

Lists the errors that have occurred since the last CLEAR. Only the first 30 errors will be listed. If more than 30 errors have occurred, the message: "ERROR: Greater than 30 errors occurred" will appear at the end of the list.

**RETURNS**

ERROR: <error message><n/><br>
 ERROR: <error message><n/><br>
           : : : :<br>
 ERROR: <error message><n/><br>
 <error message> - an error message shown in the error list.

<n/><br> - end of line.

**EXAMPLE**

To read the contents of the Error Buffer:  
 Type: ERROR

The DSM will return the last 30 errors in the format::  
     ERROR: Module or Port not found  
     ERROR: List MI no group number  
     ERROR: Group not between 1 and 8

If no errors have been logged, the DSM will return:  
     ERROR: No errors

COMMAND  
COMMAND SYNTAX  
ARGUMENTS  
DESCRIPTION

EXAMPLE

**LIST ALL**

**LIST A**

None

Lists all of the configuration variables in the order: LIST I, LIST SE, LIST T, LIST ST

To verify all of the module configuration variables:

Type: LIST A<CR>

The ENETCPM may return:

```
SET ECHO 0
SET TITLE1 Scanivalve CPM
SET TITLE2 CPM Scanivalve (c) 2001 - 2007 Ver 1.03
SET PORT 23
SET SEQ 1 PowerUp
SET SEQ 2 test1
SET SEQ 3 test2
SET SEQ 4 Seq4
SET SEQ 5 Seq5
SET SEQ 6 Seq6
SET SEQ 7 Seq7
SET SEQ 8 Seq8
SET SEQ 9 Seq9
SET SEQ 10 Seq10
SET SEQ 11 Seq11
SET SEQ 12 Seq12
SET SEQ 13 Seq13
SET SEQ 14 Seq14
SET SEQ 15 Seq15
SET SEQ 16 Seq16
SET STATE 1 power1 01010101
SET STATE 2 power2 10101010
SET STATE 3 test1 11011011
SET STATE 4 test2 00100100
SET STATE 5 State5 00000000
SET STATE 6 State6 00000000
SET STATE 7 State7 00000000
SET STATE 8 State8 00000000
SET STATE 9 State9 00000000
SET STATE 10 State10 00000000
SET STATE 11 State11 00000000
SET STATE 12 State12 00000000
SET STATE 13 State13 00000000
SET STATE 14 State14 00000000
SET STATE 15 State15 00000000
SET STATE 16 State16 00000000
SET STEP PowerUp 1 0 test1
SET LAST PowerUp 2
SET STEP test1 1 0 test1
SET LAST test1 2
SET STEP test2 1 0 test2
SET LAST test2 2
SET LAST Seq4 1
```



```
SET LAST Seq5 1
SET LAST Seq6 1
SET LAST Seq7 1
SET LAST Seq8 1
SET LAST Seq9 1
SET LAST Seq10 1
SET LAST Seq11 1
SET LAST Seq12 1
SET LAST Seq13 1
SET LAST Seq14 1
SET LAST Seq15 1
SET LAST Seq16 1
```

NOTE: The actual data returned may vary depending on the user and installation.

COMMAND  
COMMAND SYNTAX  
ARGUMENTS  
DESCRIPTION  
EXAMPLE

### **LIST IDENTIFICATION**

#### **LIST I**

None

Lists the IDENTIFICATION configuration variables.

To verify the general module identification settings:

Type: LIST I<CR>

The ENETCPM may return:

```
SET ECHO 0
SET TITLE1 Scanivalve CPM
SET TITLE2 CPM Scanivalve (c) 2001 - 2007 Ver 1.03
SET PORT 23
```

NOTE: The information returned in the Identification data may vary depending on the user.

COMMAND  
COMMAND SYNTAX  
ARGUMENTS  
DESCRIPTION  
EXAMPLE

## LIST NAME SETTINGS

### LIST SE

None

Lists the Name Settings

This command is used to verify the sequence names

Type: LIST SE<CR>

The ENETCPM may return:

```
SET SEQ 1 PowerUp
SET SEQ 2 test1
SET SEQ 3 test2
SET SEQ 4 Seq4
SET SEQ 5 Seq5
SET SEQ 6 Seq6
SET SEQ 7 Seq7
SET SEQ 8 Seq8
SET SEQ 9 Seq9
SET SEQ 10 Seq10
SET SEQ 11 Seq11
SET SEQ 12 Seq12
SET SEQ 13 Seq13
SET SEQ 14 Seq14
SET SEQ 15 Seq15
SET SEQ 16 Seq16
```

COMMAND  
COMMAND SYNTAX  
ARGUMENTS  
DESCRIPTION

EXAMPLE

## LIST SEQUENCE STEPS

### LIST ST <sequence ID>

ID 0 to 16

Lists the Delay and Sequence switch settings for a sequence. A Zero will list all 16 sequences.

This command is used to List the Delay and Switch settings for any or all or the sequences.

Type: LIST ST 1 <CR>

The ENETCPM will return the settings for sequence . They could appear as follows:

```
SET STEP PowerUp 1 0 test1
SET LAST PowerUp 2
```

Type: LIST ST 0 <CR>

The ENETCPM will return the settings for all sequences:

```
SET STEP PowerUp 1 0 test1
SET LAST PowerUp 2
SET STEP test1 1 0 test1
SET LAST test1 2
SET STEP test2 1 0 test2
SET LAST test2 2
SET LAST Seq4 1
SET LAST Seq5 1
SET LAST Seq6 1
SET LAST Seq7 1
```

```
SET LAST Seq8 1
SET LAST Seq9 1
SET LAST Seq10 1
SET LAST Seq11 1
SET LAST Seq12 1
SET LAST Seq13 1
SET LAST Seq14 1
SET LAST Seq15 1
SET LAST Seq16 1
```

COMMAND  
COMMAND SYNTAX  
ARGUMENTS  
DESCRIPTION

### LIST SWITCH STATES

**LIST T <channel>**

None

Lists all of the switch state settings. If channel 0 is specified, all channels will be listed.

EXAMPLE

To view all of the switch state settings:

Type: LIST T 0<CR>

The ENETCPM will return the settings of all switch states. They could appear as follows:

```
SET STATE 1 power1 01010101
SET STATE 2 power2 10101010
SET STATE 3 test1 11011011
SET STATE 4 test2 00100100
SET STATE 5 State5 00000000
SET STATE 6 State6 00000000
SET STATE 7 State7 00000000
SET STATE 8 State8 00000000
SET STATE 9 State9 00000000
SET STATE 10 State10 00000000
SET STATE 11 State11 00000000
SET STATE 12 State12 00000000
SET STATE 13 State13 00000000
SET STATE 14 State14 00000000
SET STATE 15 State15 00000000
SET STATE 16 State16 00000000
```

COMMAND  
COMMAND SYNTAX  
ARGUMENTS  
DESCRIPTION

### SAVE

**SAVE**

None

Commands the ENETCPM to save the RAM image of Non Volatile Memory(NVM). Any change to a configuration variable must be followed by a SAVE command if the change is to be permanent.

RETURNS

<n/

<n/ - End of line.

EXAMPLE

To save the current configuration variable settings and conversion coefficients,

Type: SAVE<CR>

COMMAND  
COMMAND SYNTAX  
ARGUMENTS

DESCRIPTION

NOTE

## SET

**SET <name> <value>**

<name> - the Configuration Variable to be set or modified.

<value> - the value of that Configuration Variable

Commands the ENETCPM to set one of the many Configuration Variables. Configuration Variables are described in a subsequent section.

Listing the Configuration Variables with the LIST command outputs the data in the format required by the SET command. This enables the user to upload data from a file that has been created by a LIST download.

COMMAND  
COMMAND SYNTAX  
ARGUMENTS  
DESCRIPTION

## START

**START <Sequence ID>**

None

Commands the ENETCPM to execute the indicated sequence..

COMMAND  
COMMAND SYNTAX  
ARGUMENTS  
DESCRIPTION

## STATUS

**STATUS**

None

Commands the ENETCPM to send a Status Packet to the client. The Status Packet is described in a subsequent section.

The STATUS command may be entered at any time. This is one of the commands that will not generate an error if entered while the ENETCPM is not READY. The DSM could return one of the following status descriptions

READY The ENETCPM is operating and ready to accept a command.

RUNNING <sequence ID> <step #> <step details>

EXAMPLES

If the STATUS command is entered while the ENETCPM is on, but inactive, the DSM will return:

Status: READY

If the STATUS command is entered while the DSM is executing a Sequence, the DSM will return:

Status: RUNNING <sequence ID> <step #> <step details>

COMMAND  
COMMAND SYNTAX  
ARGUMENTS  
DESCRIPTION

## STOP

**STOP**

None

Commands the ENETCPM to stop executing a sequence and return to the READY mode.



## CONFIGURATION VARIABLES

Configuration Variables control the way the ENETCPM functions. Each variable is assigned a “data type” description.

VARIABLE	<b>LAST &lt;Sequence ID&gt; &lt;Step number&gt;</b>
VALID VALUES	Sequence ID - 1 to 16 Or, the sequence name. The sequence name may not start with a number. The name is case sensitive.
DEFAULT VALUE	Step number - 1 to 32 Sequence ID - 1
DATA TYPE	Step number - 1 Sequence ID - Integer
DESCRIPTION	Step number - Integer Identifies the last step in a sequence.

VARIABLE	<b>PORT xxxx</b>
VALID VALUES	Any integer other than 0
DEFAULT VALUE	23
DATA TYPE	integer
DESCRIPTION	Sets the Ethernet port. The default value is 23 which is the TelNet port. A change to this variable does not take effect until the module has been rebooted.

VARIABLE	<b>SEQ &lt;Sequence number&gt; &lt;Sequence name&gt;</b>
VALID VALUES	Sequence number - 1 to 16 Sequence name - any valid ASCII string up to 64 characters. The name may not start with a number. The name is case sensitive
DEFAULT VALUE	Sequence number - 0 Sequence name - Seqx Where: x is 1 to 16 for sequences 1 to 16
DATA TYPE	Sequence number - Integer Sequence name - ASCII String
DESCRIPTION	Assigns a name to a sequence number.

**NOTE** At power up, the ENETCPM software will test for a sequence named “PowerUp”. If this sequence exists, the sequence will be executed without a network connection. If this sequence name does not exist, no sequences will be run at power up. The sequence name is case sensitive.

**STATE <State number> <name> <switch state>**

VARIABLE  
VALID VALUES      State number      -    1 to 64  
Name                    -    any valid ASCII string up to 64 characters. The name may not start with a number. The name is case sensitive  
Switch state           -    1 or 0 in the string xxxxxxxx, where each x represents channels 1 through 8, respectively.

DEFAULT VALUE      State number      -    0  
Name                    -    Statex    Where x is 1 to 64 for states 1 to 64  
Switch state           -    00000000

DATA TYPE           State number      -    Integer  
Name                    -    ASCII String  
Switch state           -    string

DESCRIPTION        Controls the state of the 8 channel outputs for each switch state.

**STEP <Sequence ID> <Step number> <State ID> <Delay>**

VARIABLE  
VALID VALUES      Sequence ID       -    1 to 16 Or, the sequence name. The sequence name may not start with a number. The name is case sensitive.  
Step number           -    1 to 32  
State ID                -    1 or 0 in the string xxxxxxxx, where each x represents channels 1 through 8, respectively. Or, the state name. The state name may not start with a number. The name is case sensitive.

DEFAULT VALUE      Delay                -    0 to 60 seconds  
Sequence ID           -    1  
Step number           -    1  
State ID                -    00000000

DATA TYPE           Delay                -    0  
Sequence ID           -    Integer  
Step number           -    Integer  
State ID                -    string  
Delay                    -    Integer

DESCRIPTION        Sets the switch state for a step and the delay in seconds at that step before the switch state is set.

**TITLE1 <title>**  
any valid ASCII string up to 64 characters  
Scanivalve ENETCPM  
ASCII String  
Sets the value of Title number 1.

**TITLE2 <title>**  
any valid ASCII string up to 64 characters  
The current software version.  
ASCII String  
Sets the value of Title number 2.

## ENETCPM Packet Definitions

The ENETCPM sends an ASCII packet to the client in response to a command.

### ENETCPM to HOST

#### ASCII Packet

This packet will be transmitted when the host issues a command:

FUNCTION DESCRIPTION	BYTES	DATA TYPE	VALUE
ASCII Data (Refer to the Command Section of this manual for the proper Command return formats).	Varies	String	Unique to Packet. Each line is terminated with a CR-LF

#### Network Protocols Supported

Physical Layer : 10Base-T IEEE 802.3  
Link Layer: INTERNET Protocol (IP)  
Transport Layer: Transmission Control Protocol (TCP)  
User Datagram Protocol (UDP)

#### ENETCPM Recommended Operation

1. Energize the unit and allow 15 minutes for warm-up.
2. While the unit is warming up, connect the Control Supply Pressure.
3. Verify that the Control Pressure Outputs are connected correctly. Refer to the appropriate ZOC or DSA Module Hardware manual for more information.
4. Connect the Digital Outputs
5. Connect to the Network.



## ENETCPM Web Server

All ENETCPM software versions have a built in web server program. This software will operate with Netscape Navigator or Microsoft Internet Explorer.

The purpose of the Web Server is to provide a means of communication between ENETCPM Modules and a PC. It is designed to give a user the tools necessary to be able to interface to a ENETCPM Module. It is not intended to be an application software. It operates in Microsoft Windows 9x/NT/2000/XP. It provides the following:

1. Easy setup of ENETCPM Modules.  
ENETCPM Web Server is menu driven. That is, it permits a user to simply select the function(s) to be modified from a pull down menu. Setup of a ENETCPM Module usually requires only a few mouse clicks.
2. Command and configuration information may be sent to ENETCPM Modules from a disk file.  
This permits a very fast setup of a ENETCPM Module. This is especially helpful when a module is to be modified during a test.
3. Display temperature values as numbers and in bar graph format.  
This permits easy setup of a module or group of modules. All data are displayed.
4. Display "scrolled" data from ENETCPM Modules.  
When this window is opened, all communications from the ENETCPM Modules are displayed.
5. Write data from ENETCPM Modules to a disk file.  
Permits storage of data in a format specified during setup.

The Web Server is designed to be connected to, and communicate with, one module. If it is necessary to connect to more than one module at a time, then multiple copies of the browser can be opened. The number of modules that can be supported at one time is dependant upon the processor speed and available memory of the Host PC.

The sample screens in this section were collected on a host computer using Microsoft Internet Explorer, Version 6.0. The ENETCPM web browser will function in most versions of Microsoft Internet Explorer and Netscape Navigator.

## Web Server Operation

Connect the ENETCPM to a PC or onto a network. The IP address of the ENETCPM must be in the same class as the PC or Network. The Ethernet cable must be a cross cable if connecting directly to a PC, or a straight connection if connecting to a hub.

This section has examples of the screens in the web browser. For these examples, the module IP address is 191.30.50.50. The address of a user's ENETCPM will most likely be different from this one. The user should substitute the IP address of the module being used wherever the IP address is mentioned

Launch Netscape Navigator, the version must be 4.74 or newer. When the browser is open, enter the following URL:

[Http://191.30.50.xxx/index.htm](http://191.30.50.xxx/index.htm)

Where: xxx is the serial number of the unit. If the IP address has been changed, use that address.

The ENETCPM Home page will open. It will be similar to the one below.

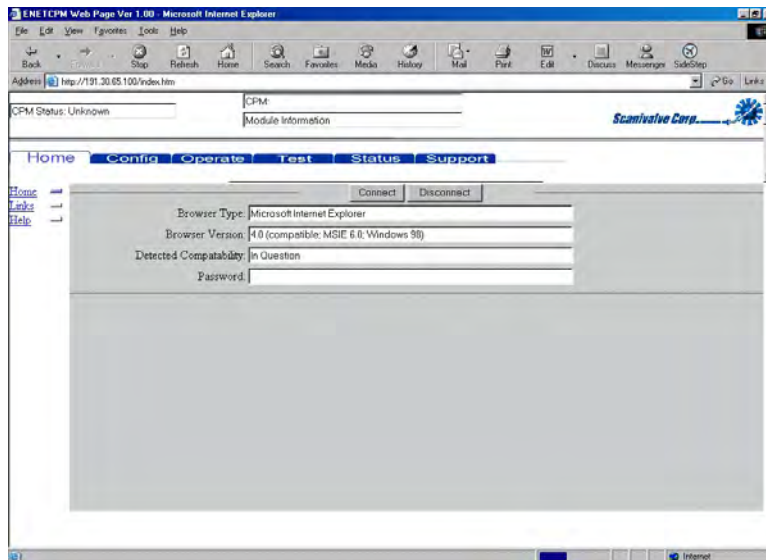

## Home

The Home page offers the options to tab to one of five other pages and connect to the ENETCPM. The other pages contain listings of the configuration variables that may be changed by a user.

The other available pages are:

- Config This page allows a user to define and name the states, which can then be arranged in sequences.
- Operate This page allows a user to select, start, and stop a sequence. It has a window to permit a user to track the sequence function.
- Test This page allows a user to switch any of the eight Digital Outputs On or Off. Each Digital Output has a light to show when it has been switched on.
- Status This page contains the Error list.
- Support This page permits a user to send commands to an ENETCPM and monitor the response.

Connect to the ENETCPM by clicking Connect.

The Title information will be loaded and, if the ENETCPM is functioning correctly, the ENETCPM Status will indicate Ready.

**NOTE:** Do not enter commands until the ENETCPM Status indicates: READY

When connected, page will be similar to the figure below.

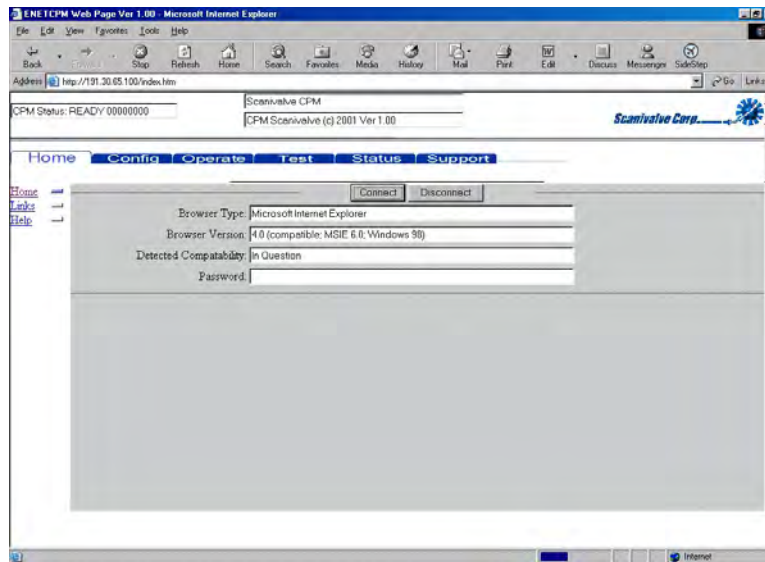

The Home page has four(4) windows.

Browser Type	This identifies the Web Browser that is communicating with the ENETCPM.
Browser Version	The version number of the host Web Browser and the operating system.
Detected Compatibility	Identifies the compatibility of the browser with the ENETCPM.
Password	This must be entered for access to the CONFIG, TEST, and SUPPORT pages. If the password has not been entered correctly and one of these pages is selected, the user will be prompted to enter the correct password:



The Password is: gnomes This may not be changed by a user.

The options for the Home page are listed on the left side of the page

Links	Links will permit a user to connect to the Scanivalve Web Site, <a href="http://www.scanivalve.com">www.scanivalve.com</a> , if the user is connected to the Internet.
Help	This page has a link to the embedded Help file. This file contains information on commands, configuration variables, and packet configurations. When this file is opened, scroll to, and click on, the command or variable in question. The browser will jump to the description of the term.

## Config

The Config page contains the Title information and the setup pages for State and Sequence. For more information on the State and Sequence configuration variables, please refer to the software section of this manual.

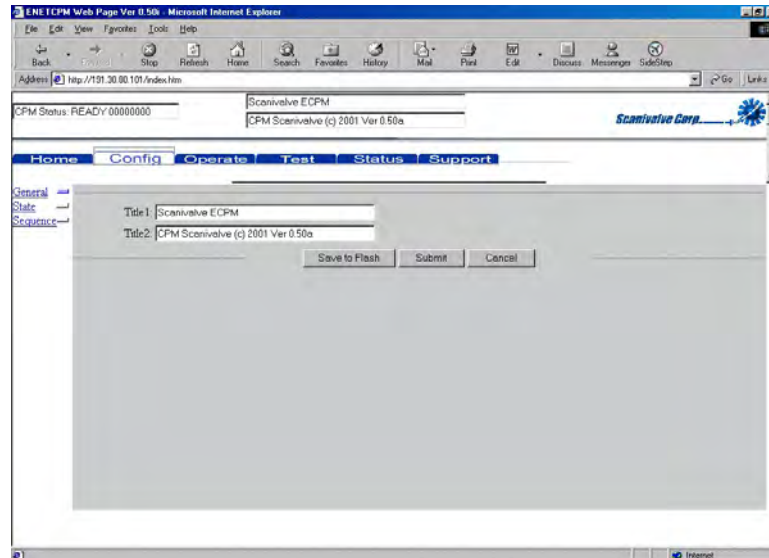

## General

This page shows the Title1 and Title2 entries

To change a value:

- Click in the window to display the cursor
- Enter the new value and click Submit.

If the window has an arrow to indicate that a pull down menu is available:

- Click on the down arrow
- Click on the desired value to highlight it
- Click Submit

If the variable has a check box:

- Click on the box to check or un-check the variable
- Click Submit

## State

This page will permit the user to

1. Set the Digital Output configuration for each State.
2. Enter a unique Name for each State.

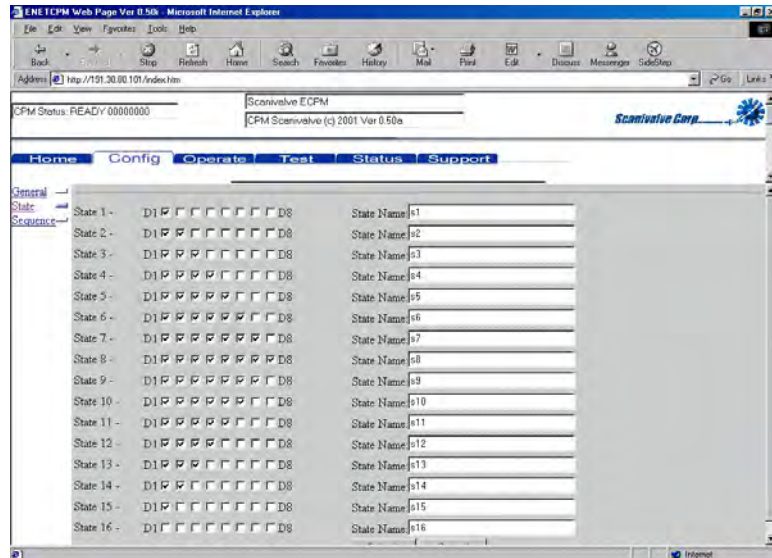

To change a value:

- Click in the window to display the cursor
- Enter the new value and click Submit.

If the window has an arrow to indicate that a pull down menu is available:

- Click on the down arrow
- Click on the desired value to highlight it
- Click Submit

If the variable has a check box:

- Click on the box to check or un-check the variable
- Click Submit

## Sequence

This page will permit the user to:

1. Select a sequence to view or modify
2. Select the state, or states, to be included in the sequence
3. Set the delay, in seconds, at each step in the sequence
4. Identify the state for each step in the sequence
5. Identify the "Last Step" in the sequence
6. Modify the Sequence name

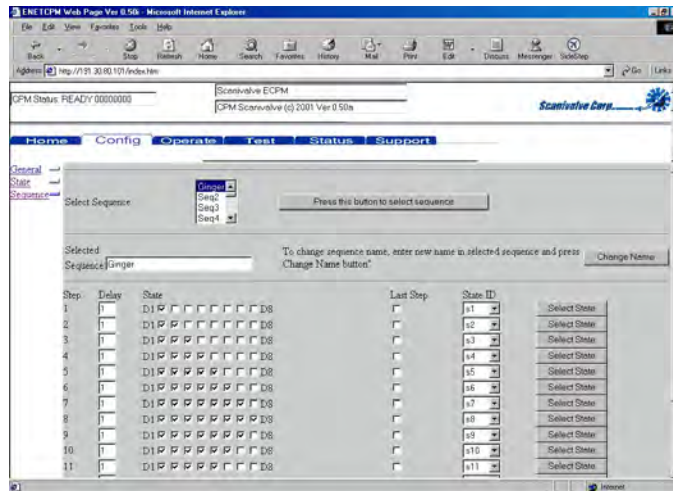

To change a value:

- Click in the window to display the cursor
- Enter the new value and click Submit.

If the window has an arrow to indicate that a pull down menu is available:

- Click on the down arrow
- Click on the desired value to highlight it
- Click Submit

If the variable has a check box:

- Click on the box to check or un-check the variable
- Click Submit

## Operate

This page will permit a user to:

2. Select a Sequence to be run.
3. Start or Stop the Sequence
4. Monitor the operation of the sequence in the Action Log.

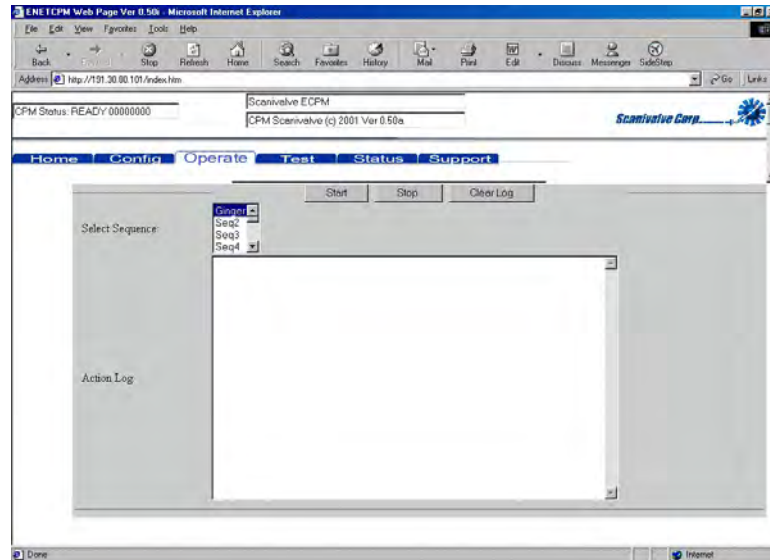

When the selected Sequence is operating, the Action Log could appear as follows:

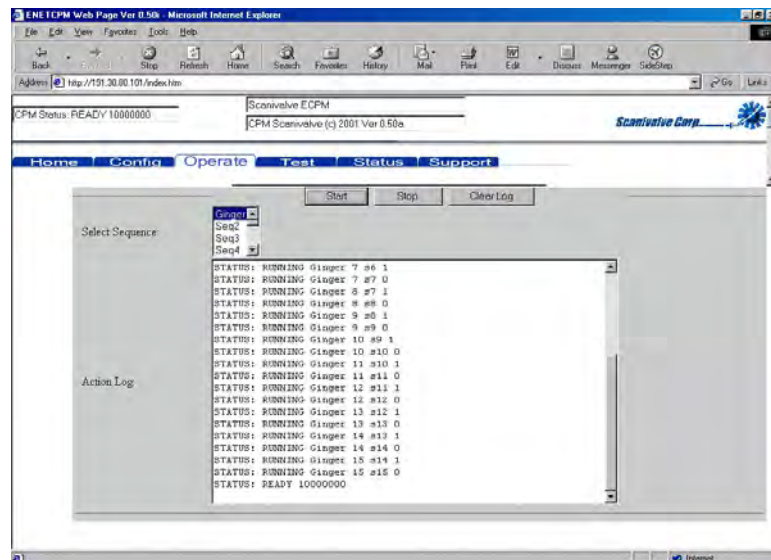



## Test

This page will permit a user to:

1. Switch one or all of the Digital Outputs On or Off
2. Verify the state of the Digital Outputs by monitoring the status lights.

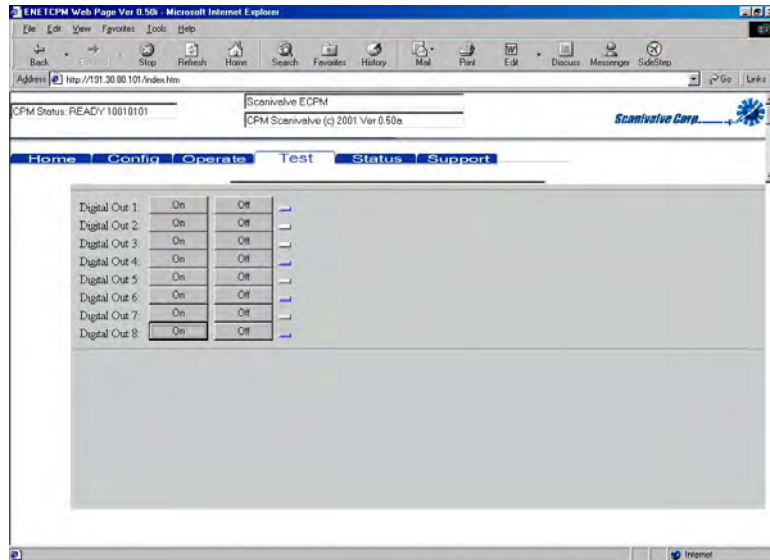

## Status

The Status page can be used to display the Error Status of the module.

The list may be updated by Clicking:

Update Errors

The Error buffer may be cleared by Clicking:

Clear Errors

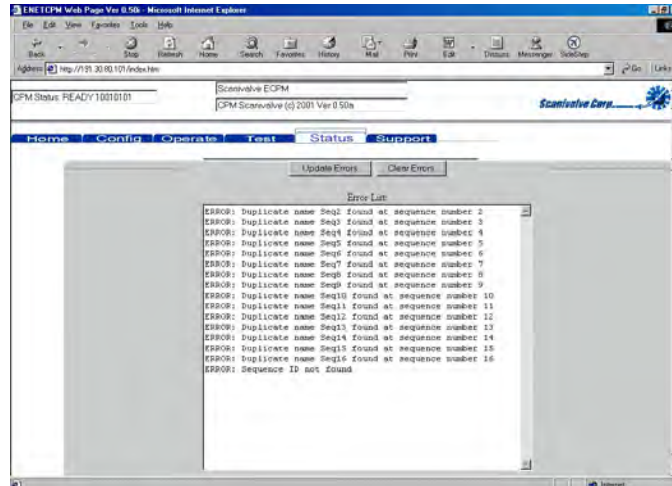

## Support

This page will permit a user to:

1. Send a command to the ENETCPM
2. Monitor the response of the ENETCPM

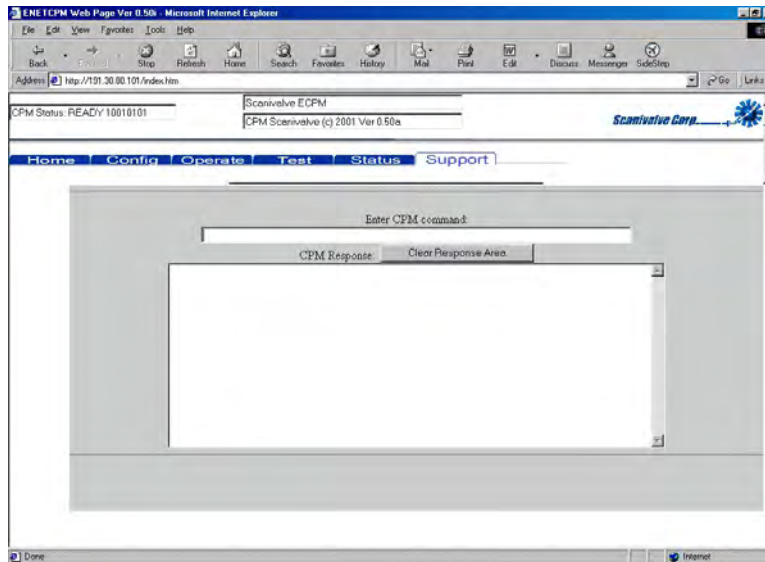

## Closing the Web Browser

It is recommended that the Web Browser be closed by first disconnecting the ENETCPM from the Browser by clicking the Disconnect button on the Home page. This will disconnect the module cleanly. Then close the Browser by clicking the X tab of by Selecting **File, Close**.

The disconnect may also be made by simply closing the Web Browser. This will create an error in the Error log of the ENETCPM.

# Host Web Browser Setup

## Internet Explorer

The Security levels in Internet Explorer are easily set. Since the DTS will normally be used on an internal network and not on the Internet, the changes required will not affect the security levels for Internet access. These instructions are valid for versions 5 and 5.5.

Start Internet Explorer

Select Tools

Select Internet Options

Click on the Security Tab

Click on the Local Internet Icon



Click on the Sites button, a smaller window will open. All three boxes must be checked.

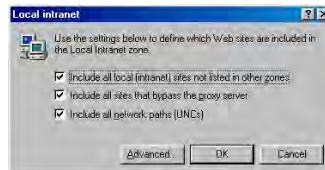

Click Advanced when all boxes are checked. The Local Internet Sites window will open.



Enter the IP Address(s) of the module(s) to be viewed on this Local Internet by entering the address(s) in the upper box and clicking Add. The IP Addresses will be listed in the Web Sites box as they are added. When all of the IP Addresses have been entered, Click on the OK. Buttons in each displayed box until only the Internet Options Window is displayed.



Click on the Custom Level Button. The Security Settings Window will open.

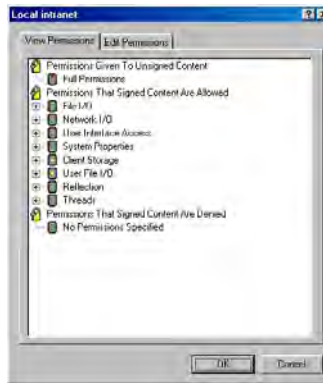

Scroll down to Java Permissions, Click the Custom Radio Button and then, Click on the Java Custom Settings Button

When the Local Internet Permissions Window opens, Click on the Edit Permissions Tab.

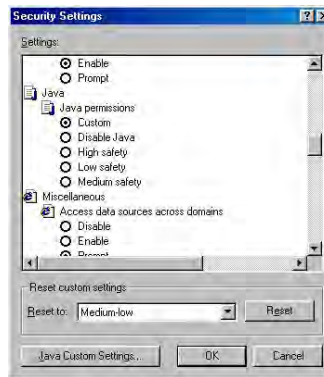

Find the Run Unsigned Content Listing and Click on the Enable Radio button. Click on the View Permissions Tab

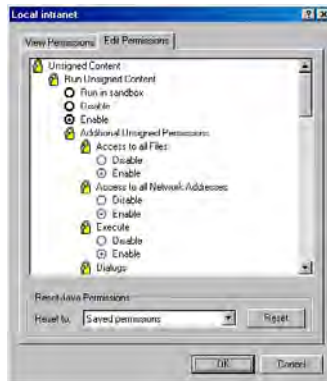

Verify that the Permissions Given to Unsigned content has a red indicator on the Full Permissions Line

Close all of the windows and return to the Web Browser by Clicking on the OK Button in each window.

## Netscape Navigator

These instructions are valid for V4.74. Other versions of Netscape Navigator may require additional or different steps.

The security levels for this version of Netscape Navigator are contained in a file named prefs.js. There may be multiple copies of this file on the local hard disk.

In the Windows Taskbar

Select: Start

Select: Find

Select: Files or Folders

Enter: press.js in the Named box and click Find Now

The search may show several copies of this file in different directories.

Using a Text Editor, such as Notepad, enter the following line in each of the files and save the revised file:

```
user_pref("signed.applets.codebase_principal_support", true);
```

The placement of this line is not critical. Netscape Navigator will sort the file.

## ENETCPM Boot Parameter Modification

The ENETCPM Series modules use an operating system licensed from VxWorks. The boot parameters are set at the factory, but these parameters may be modified to suit the needs of a specific installation. This section documents the modification of the boot parameters.

3. De-energize the ENETCPM. Connect the ENETCPM trigger/serial test cable (Scanco part #155829) from the ENETCPM to a host PC.
4. Start HyperTerminal, or an equivalent communication program. Connect the ENETCPM to a COM port on the PC Host. Set the serial parameters to 9600 BAUD, no parity, 8 data bits and 1 stop bit.
5. Energize the ENETCPM. The following sign-on information should be displayed.

```
VxWorks System Boot
Copyright 1984-1997 Wind River Systems, Inc.
```

```
CPU: HITACHI hs7709
Version: 5.3.1
BSP version: 1.1/0
Creation date: Feb 9 2000, 12:41:05
```

```
Scanivalve (c)2000, Boot loader version 1.01
Press any key to stop auto-boot...
```

6. Press any key within 3 seconds to stop the auto-boot process. If a key is not pressed within the 3 seconds time, the system will proceed to auto-boot with the existing operating system using the current setup.

NOTE: The boot-loader will continue to reboot until stopped by pressing a key under the following conditions:

- A. If boot-from-flash is selected, and no operating system is present in flash.
  - B. if boot-from-net is selected and the FTP server is not correctly set up.
7. When the auto-boot process is stopped, the boot-loader will prompt with:

```
[VxWorks Boot]:
```

To get a list of the existing boot parameters:

```
Type: p <Enter>
```

The following list is the default setup:

```
boot device           : cs
processor number      : 0
host name             : host
file name             : c:/DSA_hs/vxWorks.st
inet on ethernet (e) : 191.30.80.100
host inet (h)        : 191.30.101.109
user (u)              : DSA_HS
ftp password (pw)    : scanivalve
flags (f)             : 0x0
other (o)             : flash,000.096.093.218.000.002,10baseT
```

8. Modify the parameters as required by typing the change command at the [VxWorks Boot] prompt  
Type: c<Enter> The boot-loader prompts you for each parameter.  
  
If a particular field has the correct value and does not need to be changed,  
Press: <Enter>  
**NOTE:** If any other key is pressed, that will replace the existing information.  
  
To clear a field,  
Type: . <Enter>  
  
To quit before viewing all of the parameters,  
Type: CTRL+D.
9. After all changes have been made, verify the settings:  
Type: p<Enter> The settings are saved in flash at this point.
10. Restart the operating system, with the new settings,  
Type: @<Enter> This is the "Load and Go" command.
11. If the ENETCPM boots correctly, de-energize the ENETCPM and disconnect the serial test cable.
12. Re-apply power to the ENETCPM.



## Boot parameters and their functions:

boot device	Must not be changed from cs
processor number	Must not be changed from 0
host name	Must not be changed from host.
file name	The full pathname of the operating system file name to be booted from, when booting from the network. The default path and file in this line is the path and file used at Scanivalve.
inet on ethernet(e)	The IP address of this ENETCPM. The subnet mask may be specified when entering this parameter by entering a colon followed by the subnet mask in hex notation. I.e. 191.30.85.100:FFFFFF00
inet on backplane (b)	Must be left blank
host inet (h)	The IP address of the host to boot from.
gateway inet (g)	The IP address of a gateway node if the host is not on the same network as the ENETCPM.
user (u)	The user name that the ENETCPM uses to access the host. This is the name that must be set up in the FTP server on the host. The FTP server must be set up to provide that user name with the proper permission to read from the host directory and the password must be set correctly.
ftp password (pw)	The user password. This must be supplied to boot from host.
flags (f)	Must be 0x0
target name (tn)	Must be blank
startup script (s)	Must be blank
other (o)	This specifies the place to boot from, the MAC address, and the network media. The line must not contain any spaces and each parameter is separated by a comma. The syntax is: <bootloc>,<mac address>,<media type> Valid values are case sensitive and are as follows: <bootloc> net - Boot from network flash - Boot from flash. <mac address> ddd.ddd.ddd.ddd.ddd.ddd <media type> 10base2 - 10Base2 type 10baset - 10BaseT type

## ENETCPM Operating System Upload

This section describes the method for upgrading and uploading a new operating system to the ENETCPM. Two programs are used in the ENETCPM, the boot-loader and the operating system/ENETCPM application, referred to as the operating system.

The purpose of the boot-loader is to start the operating system from local flash or from a location on the network, such as a disk file on a host PC and to allow setting of certain key operating system parameters. The boot-loader can only be installed with special flash programming equipment. However, the boot-loader, under most normal upgrade conditions, would not need to be changed.

When upgrading a new ENETCPM operating system, the following procedure should be followed:

1. Install an FTP server, on your host PC. Scanivalve Corp recommends the War Daemon FTP Server. The installation is described in the FTP Server Installation/Configuration Procedure.
2. Use the boot parameter modification procedure to modify the boot parameters:
  - A. Change the file name parameter to the location of the vxWorks.st file.
  - B. Insure that the user parameter is set to DSA\_HS. It must match the user in the FTP server. This name may be modified by a user
  - C. Set the password to scanivalve. It must match the password in the FTP server. The password may be modified by a user.
3. Connect to the ENETCPM using TelNet
4. Issue the "UPLOAD S <full file path>" command from TelNet. Only back slashes can be used in the path name and the S must be upper case.
5. Monitor the operation with the STATUS command. When it returns READY, the upload is complete. The upload will require about 2.5 minutes to complete. If READY is returned immediately, something has been entered incorrectly.
6. When the ENETCPM returns READY, The new operating system is installed in flash memory, but not in RAM.
7. The new operating system will be effective when power is recycled.

## Appendix A - WarFTP Server

### Installation

- Copy the file: Warftp.exe into a temporary directory.
- Double click: Warftp.exe to unzip the installation files.
- Double click: Setup.exe
- A window will open prompting for an installation directory. Click Next.

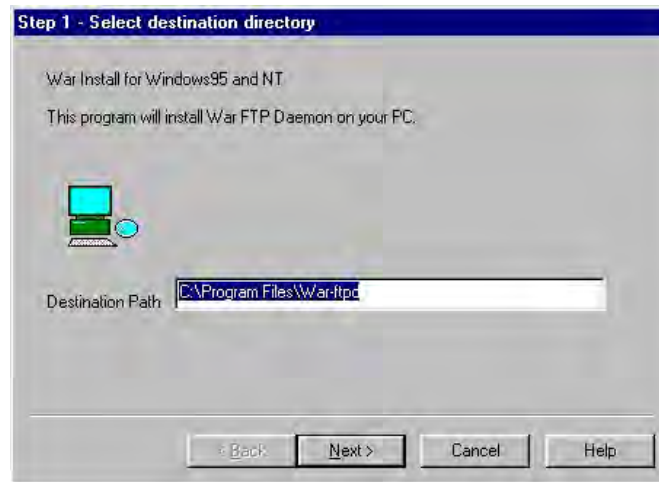

- A window will open prompting for an installation type.
- Select: Typical, and click Next.



- A Window will open prompting for a program folder. Use the default folder, and click Next.



A window will open prompting to finish the installation.

Click: Finish to complete the installation.

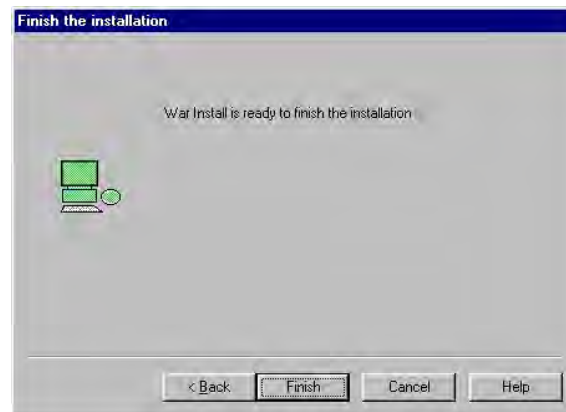

If the installation is successful, a window will open with this message. Click OK

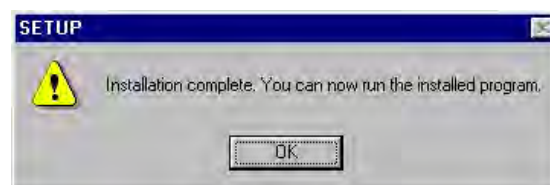

Create a folder for the DTS files.

Create the directory: C:\DTS\_HS.

Copy the file: VxWorks into this directory.

## Configuration and Setup

Start the application by double clicking the war-ftp.exe icon in the C:\Program Files\War-ftp directory.

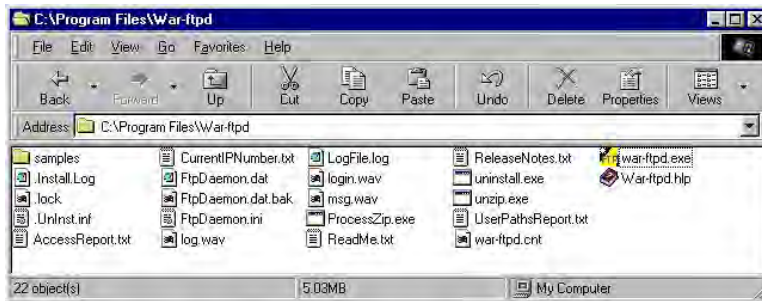

The War FTP Daemon information window will open

Enable the "Do not show this banner again" check box and click OK.



The main display window will open. It will look similar to the window below.

Select: Properties

Select: Options

From the General Tab, Enable the "Go online when started and minimize" check boxes.

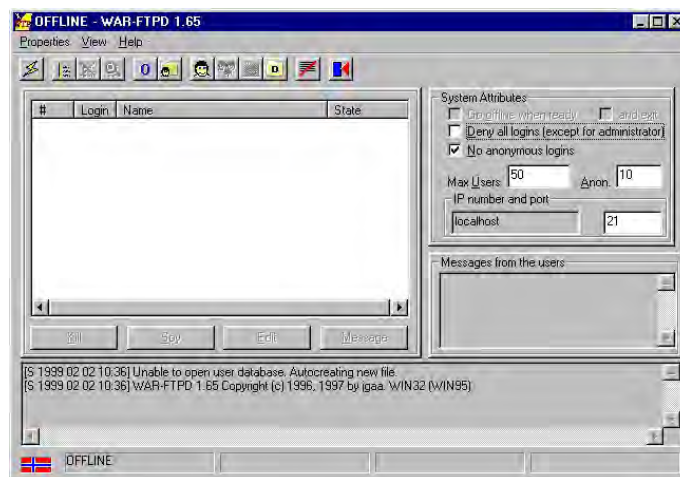

Select the Server Name Tab.

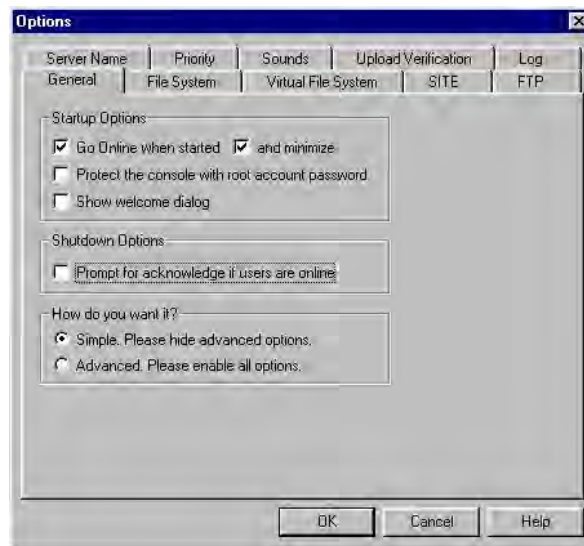

Enter a name for the FTP server.  
In this example the server will be named : host.  
Click OK.

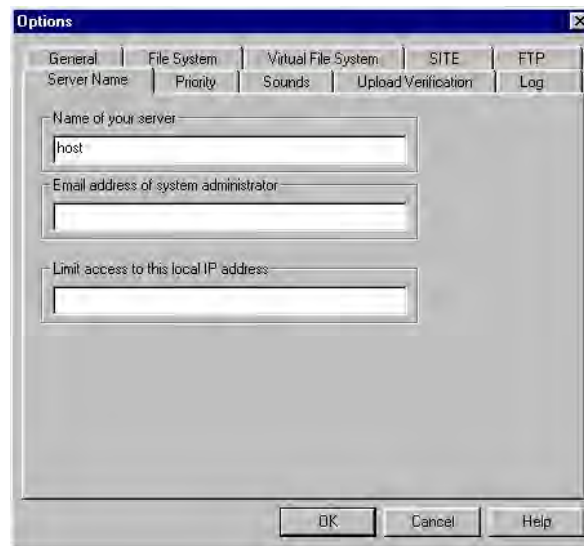

The main window will re-open  
Open the User Maintenance window:  
Click on the large smiling face icon

When the User Maintenance Window opens,  
Click the Add button

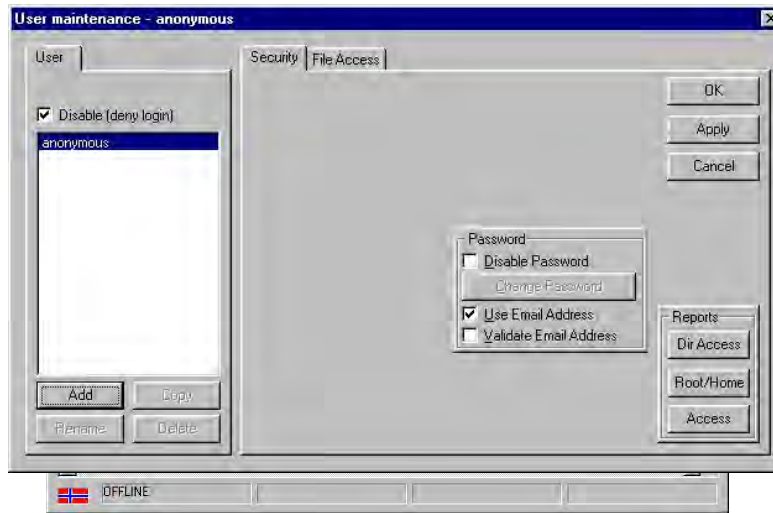

A window will open prompting a User name for the DTS  
Enter a user name for the DTS.  
For this example, the User Name will be:DTS\_HS  
Click OK.



Another window will open prompting for a password  
Enter a password for the DTS.  
For this example, the password will be: scanivalve.  
Click OK.



The User Maintenance window will re-open.  
Highlight DTS\_HS  
Select the File Access Tab  
Click on the Add Button.

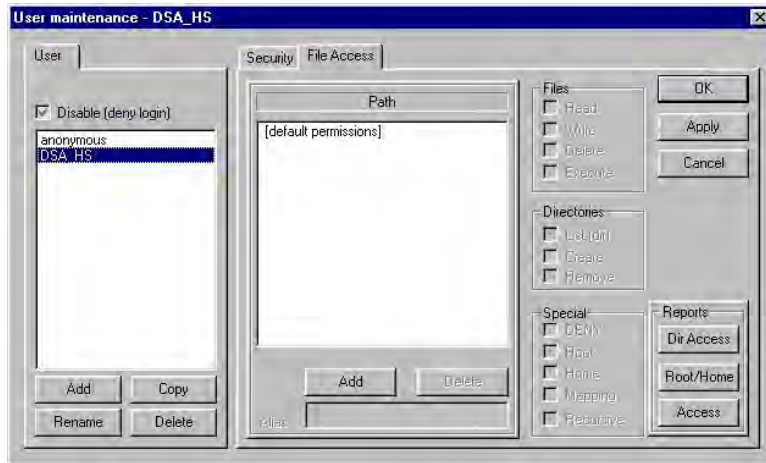

A Select Directory Window will open  
 Highlight the DTS\_HS directory.  
 Click OK.



Enable the Read and Write checkboxes in the Files frame.  
 Click : Apply  
 Click: OK

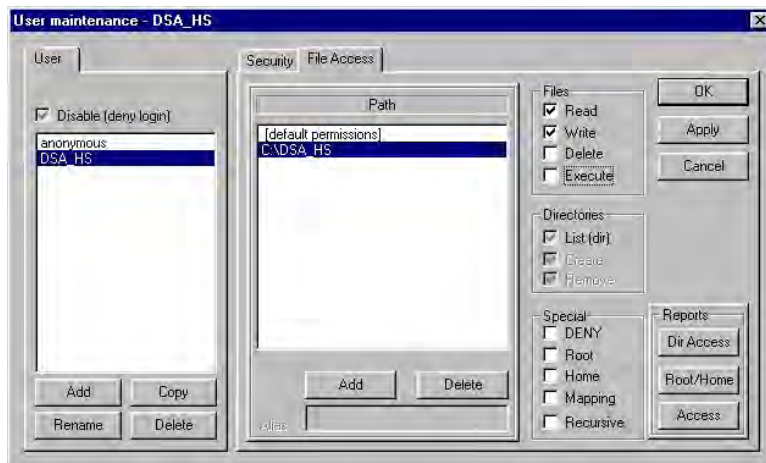

The Main Window will re-open  
 Put the server online:



Click on the lightning bolt..

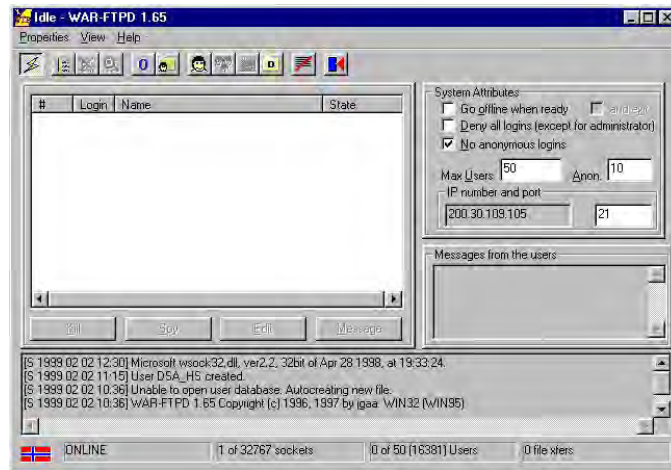

The WarFTP server is now ready

The server can be started manually as needed, or it could be configured to start automatically by placing a shortcut to War-Ftpd.exe in the Windows/Start Menu directory.

## Appendix B - Accessories

### Power Supply - PDM 1000

A single output 24 Vdc power supply is available as an accessory to the ENETCPM. This power supply will drive one ENETCPM. The Scanivalve part number is 145065-1. The unit will operate from 100 to 240 Vac at 47 to 63 Hz. The output is 24 Vdc at 2.5 A. A 10 foot (3 meter) interconnecting cable, Scanivalve part number 155819-1, is included. Longer cables are available. For more information on the power supply and cables, contact Scanivalve Corp, Customer Service Department.

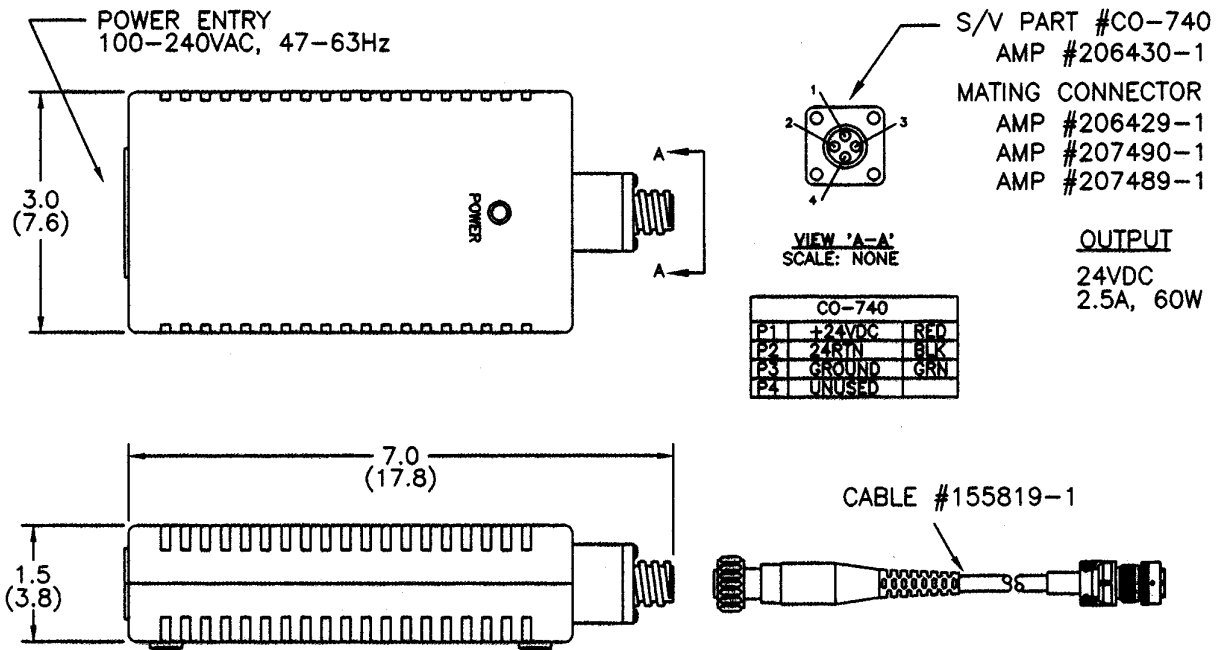

## Power Supply - PDM 3200

For users with multiple ENETCPM units, A 24 Vdc power supply capable of powering multiple units is available. This power supply will drive up to four ENETCPMs. The Scanivalve part number is 21080-1. The unit will operate from 88 to 264 Vac at 47 to 63 Hz. Each output is 24 Vdc at 2.5 A. Interconnecting cables are not included, but mating connectors are provided. Scanivalve Corp will manufacture interconnecting cables, if requested. A standard 10 foot (3 meter) interconnecting cable, Scanivalve part number 155819-1, is available. Longer cables are available on request. . For more information on the power supply and cables, contact Scanivalve Corp, Customer Service Department.

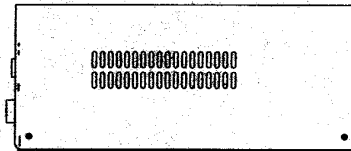
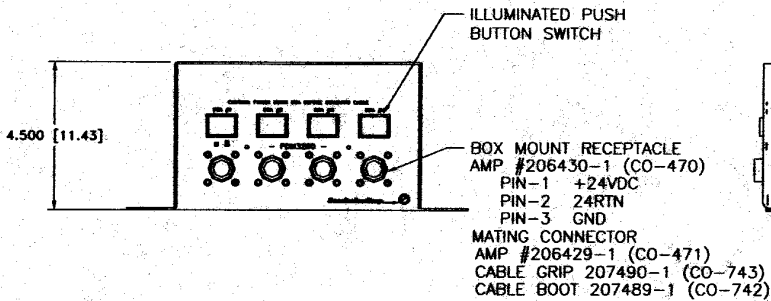
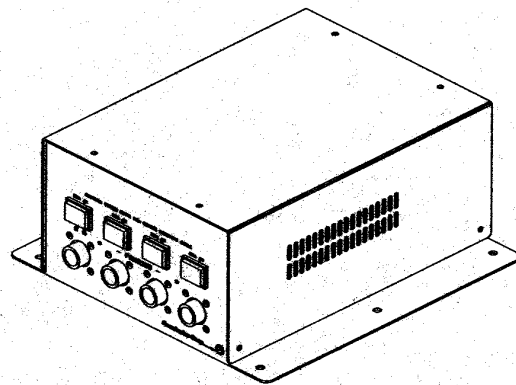
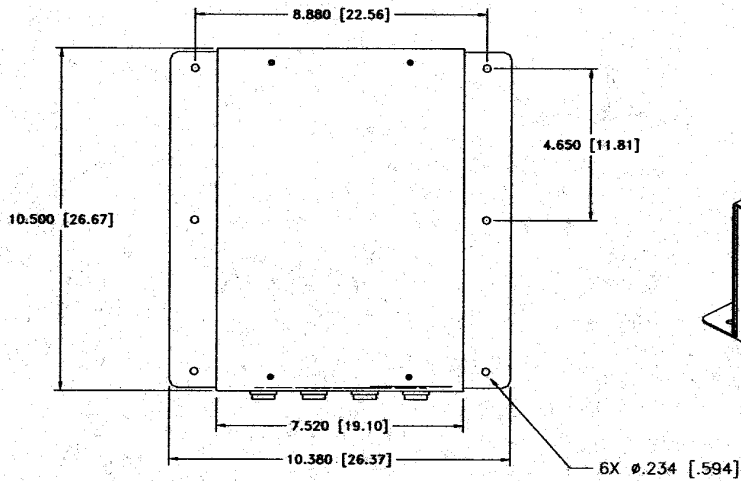

## Appendix C - Change Log

Version 1.00 - Released October 2001  
First Release

Version 1.01 - Released January 2002  
Created Help file for Web Browser

Version 1.02 - Released April 2002  
Modified bootloader program to support old and new flash chips  
Added Variable PORT to permit Ethernet ports other than 23

Version 1.03 - Released June 2007  
Added a test for a sequence named: PowerUp. If this sequence exists, it will be executed even if a network connection has not been established.