

DTS3250 Thermocouple Scanner Instruction and Service Manual

Software Version 2.01

03/2001

1722 North Madison Street
Liberty Lake, WA 99019

Tel: (800) 935-5151

(509) 891-9970

Fax: (509) 891-9481

web site: www.scanivalve.com

e-mail: scanco@scanivalve.com

Scanivalve Corp.

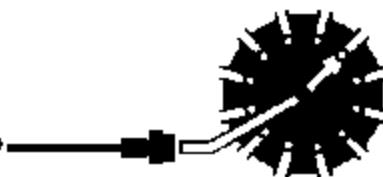

Table of Contents

Specifications	1
General Description	2
Temperature Measurement Basics	3
DTS Network/Firmware	4
DTS3250 Dimensions	5
Power Requirements	6
Trigger Requirements	7
Hardware Trigger	7
Software Trigger	7
RS 232 Communications	8
ETHERNET CONNECTIONS	9
10Base-2	9
10Base-T	9
DTS CONTROL AND CONFIGURATION	10
DTS COMMANDS	10
COMMAND LIST	11
A/D CALIBRATION	11
CLEAR	11
CLOSE HOST BINARY SERVER CONNECTION	12
CONNECT TO HOST BINARY SERVER	12
ENTER CHANNEL CALIBRATION SETPOINTS	13
ENTER RTD CALIBRATION SETPOINTS	13
ERROR	13
FILL	14
HOST BINARY SERVER COMMAND	14
LIST CALIBRATION	14
LIST CHANNEL CORRECTION SETPOINTS	14
LIST CONFIGURATION VARIABLES	15
LIST GAIN	15
LIST IDENTIFICATION	15
LIST OFFSET	16
LIST RTD CORRECTION VALUES	16
LIST RTD CONVERSION VALUES	17
LIST SCAN	17
LIST TYPE	18
LIST UTR CALIBRATION VARIABLES	18
OPEN THERMOCOUPLE TEST	19
SAVE	19

SCAN	20
SCAN TRIGGER	21
SET	21
STATUS	22
STOP	22
UPLOAD	23
VERSION	23
CONFIGURATION VARIABLES	24
SCAN VARIABLES (Group S)	24
AVG	24
BIN	24
FORMAT	24
FPS	24
PERIOD	25
QPKTS	25
TIME	25
UNITS	25
XSCANTRIG	26
CHANNEL CORRECTION VARIABLES (Group P)	26
PT	26
IDENTIFICATION VARIABLES (Group I)	27
AUTOCON	27
SIM	27
ECHO	27
HOST	27
HOSTCMD	27
CALIBRATION VARIABLES (Group C)	28
CALAVG	28
NUMPTS	28
NUMCOEF	28
THERMOCOUPLE VARIABLES (Group T)	29
TYPE <channel>	29
RTD CORRECTION VARIABLES (Group RP)	31
RPT	31
RTD CONVERSION VARIABLES (Group RTDP)	32
RTDP	32
RTDNUMPT	32
RTDNUMCOEF	32
RTDX1	32
RTDX2	33
CHANNEL GAIN CORRECTION VARIABLES (Group G)	33
GAIN	33
CHANNEL OFFSET CORRECTION VARIABLES (Group O)	33
OFFSET	33
RTD CALIBRATION VARIABLES (Group U)	34
MAXDELTA	34
RNUMPTS	34
RNUMCOEF	34
RTDB1	34
RTDB2	35
RTDM1	35
RTDM2	35

DTS Packet Definitions	36
Packet Type Table	36
Host Control Packet: Type 1	36
Command Packet	36
DTS to HOST	37
Data Packet	37
ASCII Packet	38
Network Protocols Supported	38
Special Operational Notes	38
DTS3250 Boot Parameter Modification	39
Boot parameters and their functions	41
DTS3250 Operating System Upload	42
DTS3250 Buffer Description	42
WarFTP Server	43
Installation	43
Configuration and Setup	45
Appendix A - DTS Data Flow	50
Appendix B - Thermocouple Information	51
Thermocouple Basics	51
Law of Homogeneous Materials	51
Law of Intermediate Materials	51
Law of Successive or Intermediate Temperature	51
Thermocouple Circuits	51
Thermocouple Accuracy	52
Relative Accuracy	52
Absolute Accuracy	52
Thermocouple Calibration	52
Sources of Error in Thermocouple Measurements	52
Measuring Junction	52
Extension Wires	52
Reference Junctions	53
Copper Connecting Wires	53
Thermocouple Switches	53
Noise in Thermocouple Circuits	53
Thermocouple Design	54
Size	54
Shape	54
Response	54
Heat Conduction	54
Sensor Position	54
Thermocouple Types and Descriptions	54
Type E - Chromel Constantan	54
Type J - Iron Constantan	54
Type K - Chromel Alumel	55

Type N	55
Type R	55
Type S	55
Type T - Copper Constantan	55
International Thermocouple and Extension Wire Color Codes	56
Appendix C - DTS 3250 Calibration Procedure	57
Appendix D - Change Log	62

Figures and Illustrations

Figure 1 - DTS3250	2
Figure 2 - DTS3250 Block Diagram	3
Figure 3 - Typical Pressure/Temperature Scanning System	4
Figure 4 - DTS3250 Dimensions	5
Figure 5 - Digital Sensor Array Power Wiring	6
Figure 6 - Trigger wiring	7
Figure 7 - RS232/ External Trigger Test Cable	8
Figure 8 - DTS3250 10Base-T cables	9
Figure 9 - Bonded Thermocouple, No Shield	29
Figure 10 - Unbonded Thermocouple, No Shield	29
Figure 11 - Shielded Thermocouple, Shield connected at the DTS	30
Figure 12 - Shielded Thermocouple, Shield connected at the source	30
Figure 13 - Unterminated Probe	30

Command List

ADCAL	11
CLEAR	11
CLOBIN	12
CONBIN	12
PT <index> <volts> [channel]	13
RPT <index> <volts>	13
ERROR	13
FILL	14
HOST <command>	14
LIST C	14
LIST P <channel>	14
LIST A	15
LIST G <channel>	15
LIST I	15
LIST O <channel>	16
LIST RP	16
LIST RTDP	17
LIST S	17
LIST T <channel>	18
LIST U	18
OTC	19
SAVE	19
SCAN	20
TRIG	21
SET <name> <value>	21
STATUS	22
STOP	22
UPLOAD <S or C><filepath\filename>	23
VER	23

Configuration Variables

SCAN VARIABLES (Group S)	24
AVG <value>	24
BIN <code>	24
FORMAT <code>	24
FPS <value>	24
PERIOD <value>	25
QPKTS <code>	25
TIME <code>	25
UNITS <type>	25
XSCANTRIG <code>	26
CHANNEL CORRECTION VARIABLES (Group P)	26
PT <channel> <index> <volts applied> <counts applied>	26
IDENTIFICATION VARIABLES (Group I)	27
AUTOCON <code>	27
SIM <code>	27
ECHO <code>	27
HOST <IP address> <port>	27
HOSTCMD <ASCII string>	27
CALIBRATION VARIABLES (Group C)	28
CALAVG <value>	28
NUMPTS <points>	28
NUMCOEF <coef>	28
THERMOCOUPLE VARIABLES (Group T)	29
TYPE <channel> <type> [shield connect]	29
RTD CORRECTION VARIABLES (Group RP)	31
RPT <index> <volts applied> <counts applied>	31
RTD CONVERSION VARIABLES (Group RTDP)	32
RTDP <channel> <index> <temp> <ohms>	32
RTDNUMPT <points>	32
RTDNUMCOEF <coef>	32
RTDX1 <value>	32
RTDX2 <value>	33
CHANNEL GAIN CORRECTION VARIABLES (Group G)	33
GAIN <channel> <gain value>	33
CHANNEL OFFSET CORRECTION VARIABLES (Group O)	33
OFFSET <channel> <gain value>	33
RTD CALIBRATION VARIABLES (Group U)	34
MAXDELTA <value>	34
RNUMPTS <points>	34
RNUMCOEF <coef>	34
RTDB1 <value>	34
RTDB2 <value>	35
RTDM1 <value>	35
RTDM2 <value>	35

Specifications

Inputs (Tx): 16 pairs of screw terminals plus shields.
Optional Panel Jack connections available

Thermocouple Types: E, J, K, N, R, S, and T

DTS3250 Accuracy:

Accuracy Table*	
Thermocouple Type	Accuracy
E, J, K, and N	±0.5 EC (25 microvolts)
R, S, and T	±1.0 EC (50 microvolts)

UTR Accuracy:(cold junction gradient) ±0.1EC

A/D Resolution: 22 Bit

Scan Rate: 10 samples/channel/second

Operating Temperature: -20EC to 50EC

Communication: Ethernet 10Base-T (standard)
RS-232 (Configuration Only)

Communication Protocol: TCP/IP or UDP

Mating Connector Type:
 Ethernet Bendix PT06A-8-4S-SR, 4 pin female
 Power Bendix PTO6A-8-3S-SR, 3 pin female
 Trigger/Configuration Bendix JTO6RE8-6S-SR, 6 pin female

Power (20-36Vdc): 28Vdc nominal @ 2.5A during warmup, 1.2A quiescent

External Trigger: 4 to 15 Vdc @ 6mA minimum, leading edge sensing

Common Mode Rejection: 160 db @ 0 - 60 Vdc

Weight: Standard Unit: 13.0 pounds(5.91 kg)
Panel Jacks: 12.0 pounds(5.45 kg)

Input/Output Isolation: 1000 Vdc

CE Mark Standards: IEC 1000-4.2, 1000-4.3, 1000-4.5

* System accuracy specifications are valid after a two hour warm up period.

Accuracy does not include Thermocouples or Thermocouple Extension Wire.

General Description

The DTS3250 series thermocouple acquisition system represents the next generation of Intelligent temperature scanning. This Digital Thermocouple Scanner incorporates 16 pair of thermocouple inputs, 17 22 bit A/D converters, RAM, and a micro-processor, in a rugged temperature controlled stand alone module.

An Isothermal block is incorporated for the Uniform Temperature Reference (UTR), with a $\pm 0.1^{\circ}\text{C}$ accuracy. NIST thermocouple tables for standard thermocouple types are stored in Flash Memory. The microprocessor uses these look-up tables to convert mV inputs to Engineering units. Temperature data are output in EC,EF, ER, or K .

The DTS3250 total system error is $\pm 0.5^{\circ}\text{C}$ for E, J, K, and N thermocouples, not including extension wire and external connectors.

Multiple standard thermocouple types may be used with this intelligent thermocouple scanner. The DTS 3250 can accept grounded and un-grounded thermocouples.

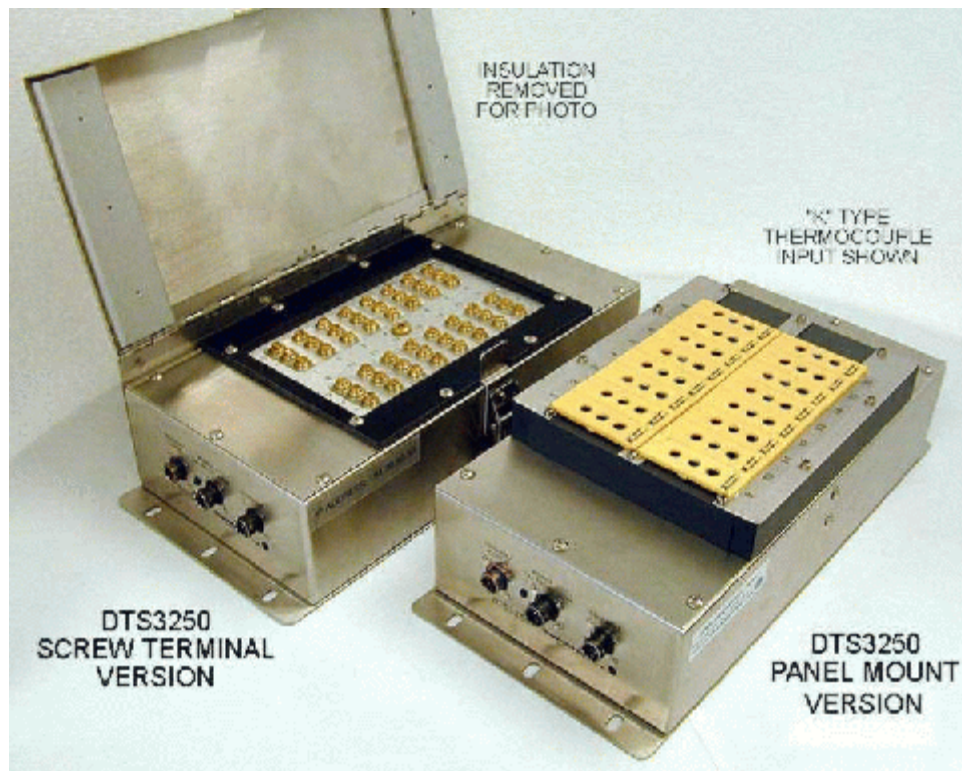

Figure 1 - DTS3250

Temperature Measurement Basics

A thermocouple is a temperature sensor consisting of two leads made from different materials. The two leads are connected at one end, which is the measuring point of the thermocouple. The other end of the leads is connected to the DTS3250 cold junction(UTR).

The thermocouple output is a mV signal, typically called Electromotive Force (EMF). The EMF is a function of the difference of the dissimilar metals at the temperature source. The relation between EMF and temperature difference depends on the materials in the two thermocouple leads.

There are a number of standardized thermocouple types available on the market. Each has different properties, which makes them more or less suitable for different temperature ranges and applications.

Accuracy of a thermocouple measurement is highly dependent upon the reference junction connection, its material installation techniques, and temperature.

The DTS3250 intelligent thermocouple scanner measures the mV signal from the thermocouples and compensates for the temperature of the cold junction .

NIST ITS-90 mV-temperature tables for each type thermocouple listed in this manual are stored in the DTS3250 memory. The DTS3250 microprocessor utilizes the compensated EMF and the NIST look-up table for conversion to engineering units. Temperature data are then output via Ethernet with TCP/IP protocol.

Refer to Appendix for more information on Thermocouples.

Figure 2 below shows a function block diagram of the DTS 3250.

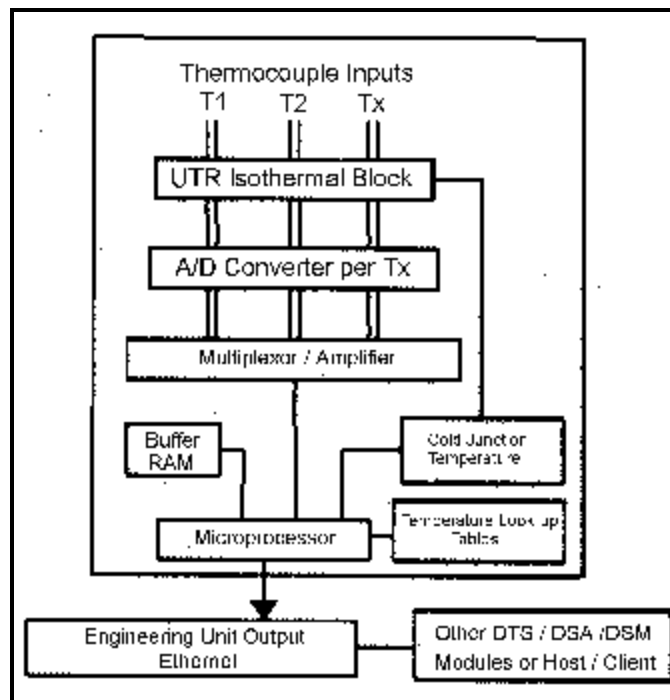

Figure 2 - DTS3250 Block Diagram

DTS Network/Firmware

DTS3250 modules accept software commands via Ethernet only. The DTS3250 modules may be controlled with an external or software scan trigger.

Each DTS module has a unique factory set 48 bit MAC address. When running TCP/IP protocol, the DTS3250 modules support ARP (Address Resolution Protocol) to enable the client/host to determine the relationship between the IP address and the Ethernet address. The IP address is user assignable.

All scan and calibration variables are configured through software by the user. This includes number of frames per scan, number of averages per frame, sampling speed, etc.

The DTS3250 firmware includes an open thermocouple test and . The firmware contains Field calibrations can be used to modify coefficients which can improve end to end accuracy. The RS232 communication connection may be used for firmware uploads and network configuration only. This connector also contains the external trigger input connections.

Figure 3 below shows a typical Pressure and Temperature Scanning system.

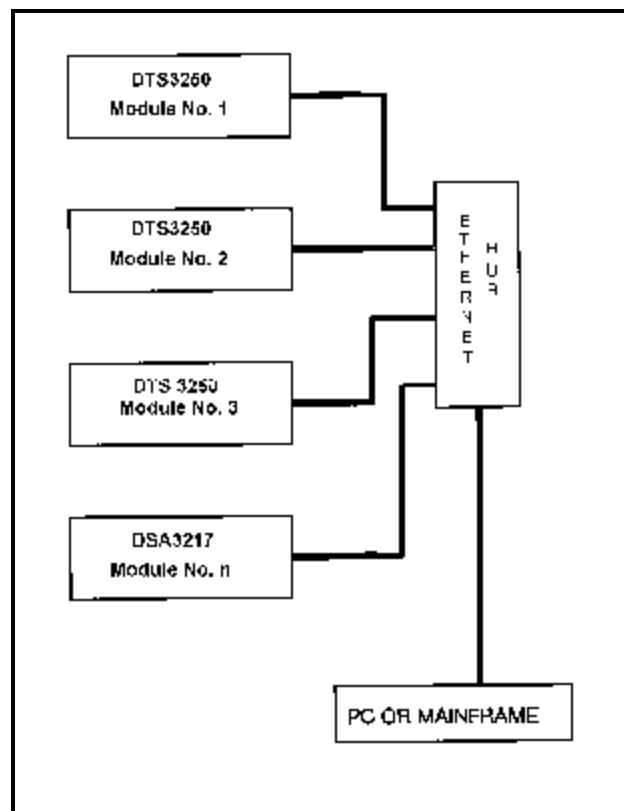
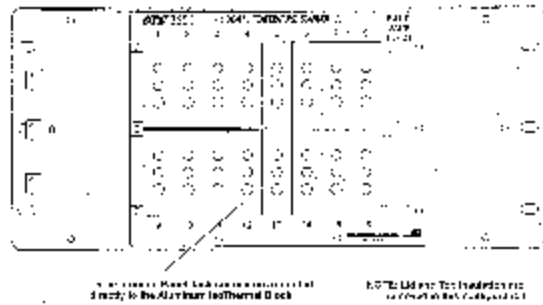
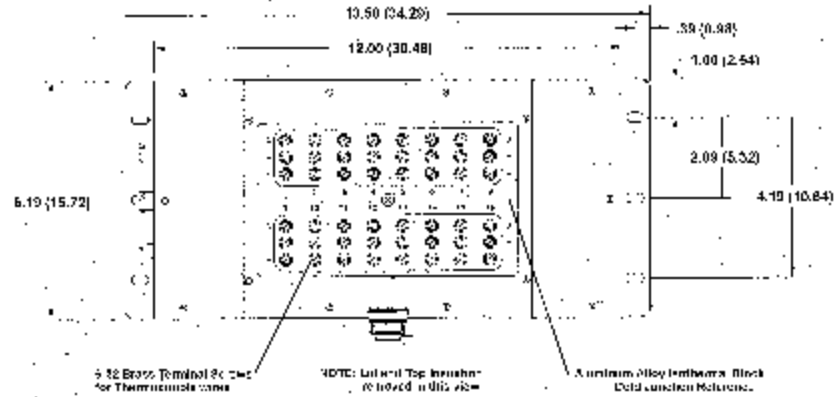

Figure 3 - Typical Pressure/Temperature Scanning System

DTS3250 Dimensions



Standard Version End View
Not Shown

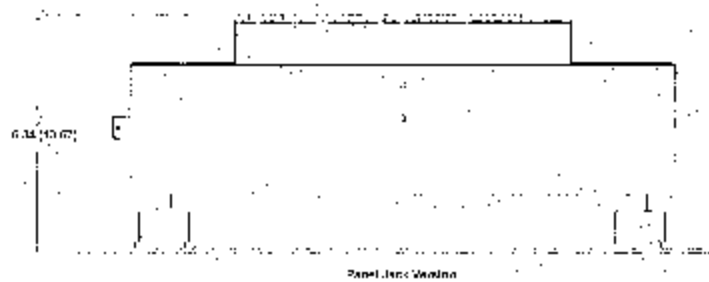
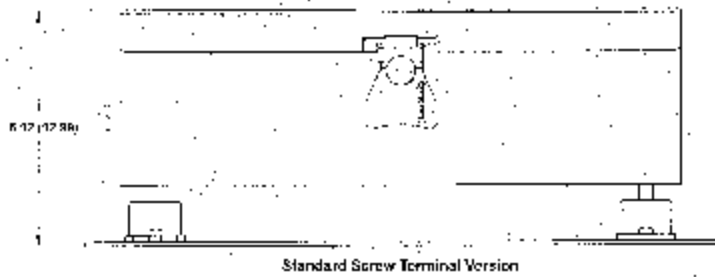

Figure 4 - DTS3250 Dimensions

Power Requirements

The DTS3250 requires $28\pm 4\text{Vdc}$ at approximately 70W during warmup. The power requirements will drop to approximately 35W when the module reaches the normal operating temperature. If the module is used in an environment where the ambient temperature is 10EC or less, power requirements could remain high. Power connections are made through a three pin connector located on the side of the module. The pinouts of the connector may be found in figure 5. The mating connector is a PT06A-8-3S-SR.

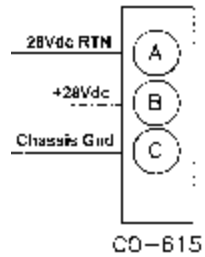

Figure 5 - Digital Sensor Array Power Wiring

Trigger Requirements

Hardware Trigger

The DTS3250 scan functions may be synchronized with other data acquisition devices by using the external trigger. The external trigger input is opto-isolated to prevent grounding problems. It is a TTL level, edge sensing device. It requires a minimum signal of 4Vdc @ 6.5 mA. It may accept voltages as high as 15 Vdc.

The external trigger will only be active if the DTS3250 XSCANTRIG variable is set to 1. When a SCAN command is issued by the Client/host, the module will enter the SCAN mode and wait for a trigger. An averaged frame of data will be output as soon as the minimum trigger edge level is achieved. Data will be output with each successive trigger pulse to the FPS variable (Frames per Scan) value or until a STOP command is issued.

DTS3250 Modules use a 6 pin connector for a combination Trigger and Serial Communications Interface. The wiring is shown in figure 6. The mating connector is a JT06RE8-6S-SR.

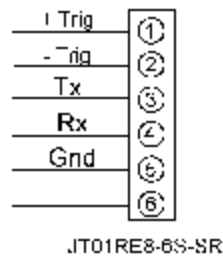

Figure 6 - Trigger wiring

Software Trigger

The DTS 3250 may also be triggered with a software trigger. The software trigger will only be active if the XSCANTRIG variable is set to 1. When a SCAN command is issued by the Client/host, the module will enter the SCAN mode and wait for a trigger. An averaged frame of data will be output as soon as the TRIG command or a <TAB> character (9 HEX or Control I) is received. Data will be output with each successive trigger command to the FPS variable (Frames per Scan) value or until a STOP command is issued.

RS 232 Communications

Every DTS3250 Module has a RS 232 output. It is available at the Serial Communications/Trigger Connector. It is required to configure the module IP address, or upload operating system upgrades. The wiring of the RS 232 output is shown in figure 7.

The RS232 inputs and outputs are not opto-isolated. Therefore, the RS232 connection could cause ground loops if it is connected during data acquisitions. Because the RS232 connection is only used for initial configuration, there is no need to maintain the connection after that setup is completed unless the external trigger function will be used.

If the RS232 connection is part of a combination Serial/Trigger cable, the RS232 connection at the host computer should be disconnected during data operations to prevent problems.

A combination RS232 and External Trigger test cable(Scanco PN 155829) is available as an option. The cable is shown below along with a wiring diagram.

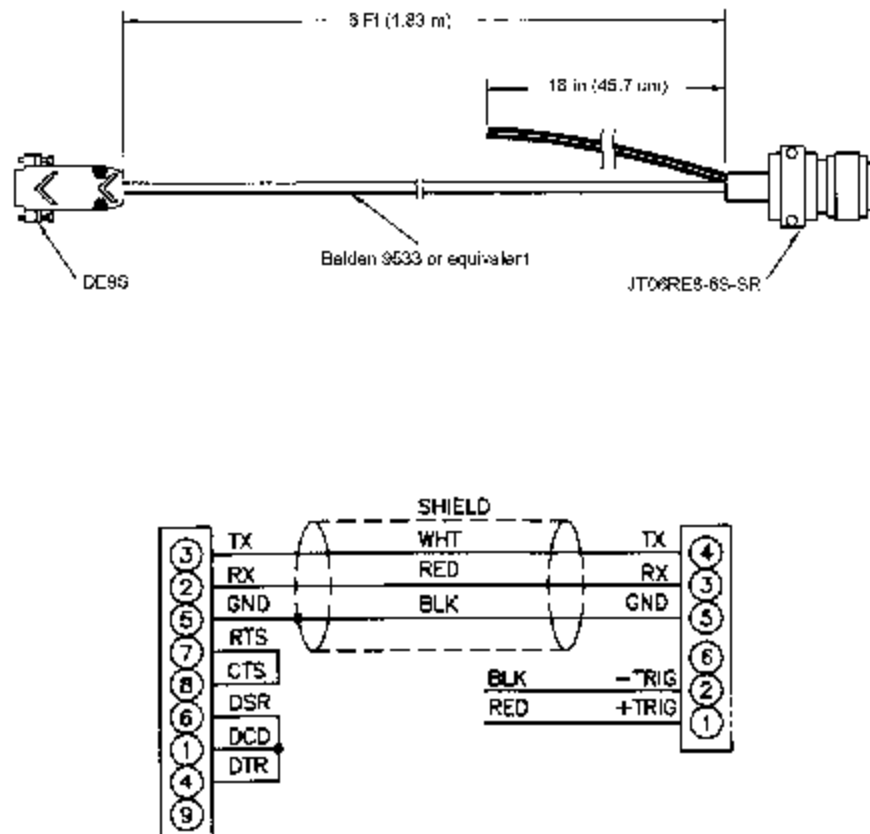

Figure 7 - RS232/ External Trigger Test Cable

ETHERNET CONNECTIONS

The DTS3250 has provisions for 10Base-T Ethernet connections only. Ethernet 10Base-2 connections may be made with media converters.

10Base-2

The 10Base-2 connection is a BNC connection. Each module is provided with a BNC-T connector. A 50 ohm terminator is available as an option. Modules configured for 10Base-2 are connected in a multi-drop configuration. Each module has a BNC-T connected at the BNC connector. A coaxial cable is run from the host computer and connected module to module. A 50 ohm terminator must be connected to BNC-T connector at the host computer and the last module in the string. The maximum number of modules that may be connected on a 10Base-2 string is 1024. The minimum length of coaxial cable between modules is 0.5 meters. The maximum length of the 10Base-2 string is 1.5 kilometers. It is recommended that IEEE 802.3 coaxial cable (Belden-E 82907 or equivalent) be used, but RG-58 coaxial cable will function correctly in most applications. This option is not available at this time.

10Base-T

The 10Base-T connection uses a Bendix connector at the module, which must be interfaced to the standard RJ-45 connector. A 10Base-T connection may be straight through (pin to pin) or crossover. A straight through cable must be used if the module is connected to a hub. Crossover connections are used if the module is connected directly to the host computer. It is recommended that Category Five cables be used. The maximum length for 10Base-T cables is 100 meters, but signal strength can be attenuated at this distance. A repeater is required for 10Base-T cable runs greater than 100 meters.

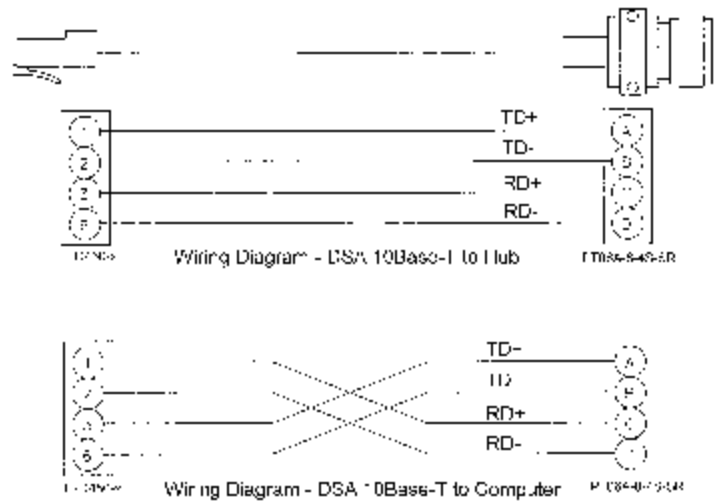

Figure 8 - DTS3250 10Base-T cables

DTS CONTROL AND CONFIGURATION

The operation of each DTS is controlled by sending ASCII commands over the TelNet port(port 23) to units selected by network addressing. The DTS returns any data or information over the network to the requesting client/host in ASCII or Binary format depending upon the settings of a configuration variable. Binary data transfers are delivered across an additional binary transfer port.

Binary transfers may be in TCP or UDP protocol. TCP requires that a Host provide a Host Binary Server program. When a DTS initiates the connection to the binary port, it can send data to the host in packet form. The port and IP address are configurable. When UDP protocol is used, no connection is required.

DTS COMMANDS

The DTS software runs as embedded software on the DTS 3250 temperature scanner hardware. It performs the following general tasks:

- 1) Read and filter the raw A/D counts that represent temperature.
- 2) Convert the A/D counts to user chosen temperature units.
- 3) Receive and execute commands from the Ethernet Link.
- 4) Allow the configuration to be saved through power down.
- 5) Output converted data, status, setup and calibration data over the Ethernet Link.
- 6) Set the DTS Physical Ethernet Address(MAC Address).
- 7) Protocol to be TCP/IP.
- 8) Support the user in troubleshooting the DTS hardware and system.

When operating in the ASCII mode or UDP, the DTS is the client. In Binary or TCP mode, the DTS is the Host.

When a DTS module is in a "NOT READY" mode, all commands are disabled except STATUS and STOP.

TCP/IP does not guarantee that packet boundaries will be maintained between a Host and a DTS module. Therefore, **ALL** commands from a Host **MUST** be terminated properly with one of four options. The DTS will detect and adjust to the termination option being used by a Host.

The four options are:

- CR (ASCII 13)
- LF (ASCII 10)
- LF-CR (ASCII 10 - ASCII 13)
- CR-LF (ASCII 13 - ASCII 10)

The current DTS RS232 interface is designed for initial boot configuration only.

COMMAND LIST

COMMAND	A/D CALIBRATION
COMMAND SYNTAX	ADCAL
ARGUMENTS	None
DESCRIPTION	Commands the DTS to calibrate the A/D converters. The A/D converters are calibrated automatically at power up and whenever the period configuration variable is set. It is possible for errors in the conversion if the temperature of the DTS has changed significantly since power up. In this case, the A/D converters can be calibrated by issuing this command.
RETURNS	<i><nb></i> <i><nb></i> - end of line.
EXAMPLE	To calibrate the A/D converters after several hours of operation, the following command would be issued: ADCAL <CR> The A/D converters will be calibrated. The time depends upon the setting of CALAVG. If CALAVG is set to 1, the time will be several seconds. If CALAVG is set to 64 this can require several minutes.
COMMAND	CLEAR
COMMAND SYNTAX	CLEAR
ARGUMENTS	None
DESCRIPTION	Commands the DTS to clear any errors that have occurred. The errors are sent to the client in an ASCII Packet. ASCII Packets are described in a subsequent sections.
RETURNS	<i><nb></i> <i><nb></i> - end of line.
EXAMPLE	To clear any errors listed in the ERROR Buffer, the following command would be issued: CLEAR <CR> The ERROR buffer will be cleared

COMMAND	CLOSE HOST BINARY SERVER CONNECTION
COMMAND SYNTAX	CLOBIN
ARGUMENTS	None
DESCRIPTION	Commands the DTS to close the connection to the Host Binary Server. This command will only be accepted by the DTS when the DTS is in the READY mode.
RETURNS	<nb> <nb> - end of line.
EXAMPLE	To close the connection to the Host Binary Server, the following command would be issued: <p style="text-align: center;">CLOBIN <CR></p> <p>The connection will be terminated</p>

COMMAND	CONNECT TO HOST BINARY SERVER
COMMAND SYNTAX	CONBIN
ARGUMENTS	None
DESCRIPTION	Commands the DTS to connect to the Host Binary Server configured through the HOST configuration variable. If the DTS is in the UDP mode or if a TCP connection is already established, an Error will be generated. This command will only be accepted when the DTS is in the READY mode.
RETURNS	<nb> <nb> - end of line.
EXAMPLE 1	A DTS is not connected to a server, is not in the UDP mode and is in the READY mode. A CONBIN command is generated to open a connection to the Host. The following command would be issued: <p style="text-align: center;">CONBIN <CR></p> <p>The DTS will be connected to the Host.</p>
EXAMPLE 2	A DTS is not connected to a server, is in the UDP mode and is in the READY mode. A CONBIN command is generated to open a connection to the Host. The following command would be issued: <p style="text-align: center;">CONBIN <CR></p> <p>The DTS will not connect to the Host and an Error will be generated.</p>
EXAMPLE 3	A DTS is not connected to a server, is in the UDP mode and is in the SCAN mode. A CONBIN command is generated to open a connection to the Host. The following command would be issued: <p style="text-align: center;">CONBIN <CR></p> <p>The DTS will not connect to the Host and an Error will be generated.</p>

COMMAND
COMMAND SYNTAX
ARGUMENTS

ENTER CHANNEL CALIBRATION SETPOINTS

PT <index> <volts> [channel]

Index - The setpoint number, 0 to 7 for setpoints 1 to 8.
Volts - The applied voltage.
Channel - Optional, If a channel is not specified, the setpoint voltage will be applied to all channels.

DESCRIPTION

This command enters the voltage correction to be applied at a given setpoint for one or more channels. The values for the setpoints do not have specific limitations.

EXAMPLES

To enter a value for setpoint 1 for all channels:

Type: PT 1 1.256<Enter>

To enter a value for setpoint 2 for channel 9:

Type: PT 2 1.744 9<Enter>

COMMAND
COMMAND SYNTAX
ARGUMENTS

ENTER RTD CALIBRATION SETPOINTS

RPT <index> <volts>

Index - The setpoint number, 0 to 7 for setpoints 1 to 8.
Volts - The applied voltage.

DESCRIPTION

This command enters the voltage correction to be applied at a given setpoint for the RTD's. The values for the setpoints must be between 0.095 Vdc and 0.131 Vdc which represents temperatures from -13" C to 80" C . The voltage must be inserted in the RTD1 input.

EXAMPLES

To enter a value for setpoint 1 for the RTD's:

Type: RPT 1 0.095<Enter>

To enter a value for setpoint 2 for the RTD's:

Type: RPT 2 0.998<Enter>

COMMAND
COMMAND SYNTAX
ARGUMENTS
DESCRIPTION

ERROR

ERROR

None

Lists the errors that are stored and listed after a CLEAR. Only the first 29 errors will be listed. If more than 29 errors have occurred, the message: "ERROR: Max Errors exceeded "will appear at the end of the list. An Error List may be found in Appendix D. The return format is:

ERROR: error

EXAMPLE

To read the contents of the Error Buffer:

Type: ERROR<Enter>

The DTS will return the last 29 errors in the format::

If no errors have been logged, the DTS will return:

ERROR: No errors

COMMAND
COMMAND SYNTAX
ARGUMENTS
DESCRIPTION

FILL

FILL

None

Activates the setpoint data. If Setpoints are configured, a FILL will be executed automatically at power-up. A FILL can be executed manually at any time.

EXAMPLE

To execute a FILL and activate the setpoints:

Type: FILL<CR>

COMMAND
COMMAND SYNTAX
ARGUMENTS

HOST BINARY SERVER COMMAND

HOST <command>

Command - An ASCII command that would be recognized by the Host Binary Server.

DESCRIPTION

This command will pass a Host Binary Server command through the DTS to the Host Binary Server

RETURNS

<nb>

<nb> - end of line.

COMMAND
COMMAND SYNTAX
ARGUMENTS
DESCRIPTION
EXAMPLE

LIST CALIBRATION

LIST C

None

Lists the calibration configuration variables.

To view the calibration configuration variable settings:

Type: LIST C<CR>

The DTS will return the calibration configuration variable settings. They could appear as follows.

```
SET NUMPTS 3
SET NUMCOEF 3
SET CALAVG 4
```

COMMAND
COMMAND SYNTAX
ARGUMENTS
DESCRIPTION

LIST CHANNEL CORRECTION SETPOINTS

LIST P <channel>

Channel - 0 to 16

Lists the calibration setpoints for the channel listed. If channel 0 is specified, the setpoints for all channels will be listed.

EXAMPLE

To view the calibration setpoints for channel 1:

Type: LIST P 1<CR>

The DTS returns:

```
SET PT 1 0 -0.01 -270952
SET PT 1 1 0.00 0
SET PT 1 2 0.07 1896664
```

NOTE: The values shown here are values for a perfect module. The actual calibration setpoints will be different.

COMMAND
COMMAND SYNTAX
ARGUMENTS
DESCRIPTION
EXAMPLE

LIST CONFIGURATION VARIABLES

LIST A

None

Lists all of the Configuration Variables.

To view or log the configuration variables:

Type: LISTA<CR>

The DTS will return all configuration variables

COMMAND
COMMAND SYNTAX
ARGUMENTS
DESCRIPTION
EXAMPLE

LIST GAIN

LIST G <channel>

Channel - 0 to 16

Lists the thermocouple gain correction assigned to the channel listed. If channel 0 is listed, all 16 gains will be returned.

To view the thermocouple gain settings:

Type: LIST G 0<CR>

The DTS will return all of the thermocouple gain settings. They could appear as follows.

```
SET GAIN 1 1.11
SET GAIN 2 1.01
SET GAIN 3 0.98
SET GAIN 4 1.12
SET GAIN 5 1.01
SET GAIN 6 1.15
SET GAIN 7 1.00
SET GAIN 8 1.11
SET GAIN 9 0.99
SET GAIN 10 0.98
SET GAIN 11 1.10
SET GAIN 12 1.01
SET GAIN 13 1.06
SET GAIN 14 1.00
SET GAIN 15 0.99
SET GAIN 16 1.10
```

COMMAND
COMMAND SYNTAX
ARGUMENTS
DESCRIPTION
EXAMPLE

LIST IDENTIFICATION

LIST I

None

Lists the IDENTIFICATION configuration variables.

To verify the general module configuration settings:

Type: LIST I<CR>

The DTS will return:

```
SET ECHO 0
SET SIM 0
SET AUTOCON 1
SET HOST 191.30.109.105 5001
SET HOSTCMD set
```

NOTE

A user must be very careful when modifying one of these variables. An incorrect value in one of these variables could have a detrimental affect on the operation of the module.

COMMAND
COMMAND SYNTAX
ARGUMENTS
DESCRIPTION

LIST OFFSET

LIST O <channel>

Channel - 0 to 16

Lists the thermocouple offset correction assigned to the channel specified. If channel 0 is specified, all 16 offsets will be returned. The OFFSET values are A/D counts.

EXAMPLE

To view all of the thermocouple offset settings:

Type: LIST O 0<CR>

The DTS will return the thermocouple offset settings. They could appear as follows.

```
SET OFFSET 1 120
SET OFFSET 2 77
SET OFFSET 3 78
SET OFFSET 4 112
SET OFFSET 5 101
SET OFFSET 6 115
SET OFFSET 7 60
SET OFFSET 8 11
SET OFFSET 9 99
SET OFFSET 10 101
SET OFFSET 11 44
SET OFFSET 12 57
SET OFFSET 13 16
SET OFFSET 14 124
SET OFFSET 15 81
SET OFFSET 16 25
```

COMMAND
COMMAND SYNTAX
ARGUMENTS
DESCRIPTION

LIST RTD CORRECTION VALUES

LIST RP

None

Lists the RTD correction values

EXAMPLE

This command is used to verify the RTD correction values of the DTS.

Type: LIST RP<CR>

The DTS will return:

```
SET RPT 0 0.095000 1287022
SET RPT 1 0.105000 1557974
SET RPT 2 0.131000 1774736
```

NOTE: The values shown here are values for a perfect module. The actual calibration setpoints will be different.

COMMAND
COMMAND SYNTAX
ARGUMENTS
DESCRIPTION

LIST RTD CONVERSION VALUES

LIST RTDP

None

Lists the RTD conversion

EXAMPLE

This command is used to verify the RTD correction values of the DTS.

Type: LIST RTDP<CR>

The DTS will return:

```
SET RTDP 1 0 0.00000 100.0000
SET RTDP 1 1 100.000 138.50000
SET RTDP 2 0 0.00000 100.0000
SET RTDP 2 1 100.000 138.50000
SET RTDNUMCOEF 2
SET RTDNUMPTS 2
SET RTDX1 1.000000
SET RTDX2 1.000000
```

NOTE: The values shown here are values for a perfect module. The actual calibration setpoints may be different.

COMMAND
COMMAND SYNTAX
ARGUMENTS
DESCRIPTION

LIST SCAN

LIST S

None

Lists the SCAN configuration variables

EXAMPLE

This command is used to verify the general scan settings of the DTS

Type: LIST s<CR>

The DTS will return:

```
SET PERIOD 6250
SET AVG 16
SET FPS 100
SET XSCANTRIG 0
SET FORMAT 0
SET BIN 1
SET QPKTS 1
SET UNITS C
SET TIME 1
```

COMMAND
COMMAND SYNTAX
ARGUMENTS
DESCRIPTION

EXAMPLE

LIST TYPE

LIST T <channel>

None

Lists the thermocouple TYPE assigned to the channel specified. If channel 0 is specified, all channels will be listed.

To view all of the thermocouple type settings:

Type: LIST T 0<CR>

The DTS will return the thermocouple type settings. They could appear as follows.

```
SET TYPE 1 K 1
SET TYPE 2 K 1
SET TYPE 3 K 1
SET TYPE 4 N 1
SET TYPE 5 N 1
SET TYPE 6 E 0
SET TYPE 7 R 0
SET TYPE 8 R 0
SET TYPE 9 S 1
SET TYPE 10 S 1
SET TYPE 11 T 1
SET TYPE 12 T 1
SET TYPE 13 E 1
SET TYPE 14 J 1
SET TYPE 15 K 1
SET TYPE 16 E 1
```

COMMAND
COMMAND SYNTAX
ARGUMENTS
DESCRIPTION

EXAMPLE

LIST UTR CALIBRATION VARIABLES

LIST U

None

Lists the RTD calibration configuration variables

This command is used to verify the calibration configuration settings of the DTS.

Type: LIST U<CR>

The DTS will return:

```
SET RTDM1 2.597403
SET RTDM2 2.597403
SET RTDB1 -259.7403
SET RTDB2 -259.7403
SET RNUMCOEF 3
SET RNUMPTS 3
SET MAXDELTA 0.25000
```

NOTE: The values shown here are values for a perfect module. The actual calibration setpoints may be different.

COMMAND
COMMAND SYNTAX
ARGUMENTS
DESCRIPTION

OPEN THERMOCOUPLE TEST

OTC

None

Commands the DTS to test for open thermocouples. The command causes a small current to be applied to each thermocouple. If a thermocouple is found to be open an error, an error is logged and bit 13 in the channel status element of the data packet is set to a 1. This command is NOT performed automatically at power up.

RETURNS

<nb>

<nb> - end of line.

EXAMPLE

To test fo open thermocouples, the following command would be issued:

OTC<CR>

COMMAND
COMMAND SYNTAX
ARGUMENTS
DESCRIPTION

SAVE

SAVE

None

Commands the DTS to save the RAM image of Non Volatile Memory(NVM). Any change to a configuration variable must be followed by a SAVE command if the change is to be permanent.

RETURNS

<nb>

<nb> - End of line.

EXAMPLE

To save the current configuration variable settings and conversion coefficients,

Type: SAVE<CR>

COMMAND
COMMAND SYNTAX
ARGUMENTS
DESCRIPTION

SCAN

SCAN

None

Commands the DTS to scan the pressure sensors and send Scan packets to the client. Data are returned immediately if XSCANTRIG is set to 0. If XSCANTRIG is set to 1, data will be returned after a hardware trigger, or a software trigger. For more information on software triggers, refer to the SCAN TRIGGER command. For Hardware trigger requirements, refer to the Trigger Requirements section.

EXAMPLE 1

A scan command is executed with EU set to 1, BIN set to 0, and FORMAT set to 0. Data are scrolled and will be displayed as follows:

```
Frame # <number>
Time <time> <Fs or ms>
<chan> <temp eu>
  "      "
  "      "
<chan> <temp eu>
```

EXAMPLE 2

A scan command is executed with EU set to 0, BIN set to 0, and FORMAT set to 0. Data are scrolled and will be displayed as follows:

```
Frame # <number>
Time <time> <Fs or ms>
<chan> <temp counts>
  "      "
  "      "
<chan> <temp counts>
```

EXAMPLE 3

A scan command is executed with EU set to 1, BIN set to 0, and FORMAT set to 1. Data are scrolled and will be displayed as follows:

```
Frame = <number> Time = <time> <Fs or ms>
<chan> <temp eu> <chan><temp eu> <chan> <temp eu> <chan> <temp eu>
<chan> <temp eu> <chan><temp eu> <chan> <temp eu> <chan> <temp eu>
<chan> <temp eu> <chan><temp eu> <chan> <temp eu> <chan> <temp eu>
<chan> <temp eu> <chan><temp eu> <chan> <temp eu> <chan> <temp eu>
```

EXAMPLE 4

A scan command is executed with EU set to 0, BIN set to 0, and FORMAT set to 1. Data are scrolled and will be displayed as follows:

```
Frame = <number> Time = <time> <Fs or ms>
<chan> <temp cts> <chan><temp cts> <chan> <temp cts> <chan> <temp cts>
<chan> <temp cts> <chan><temp cts> <chan> <temp cts> <chan> <temp cts>
<chan> <temp cts> <chan><temp cts> <chan> <temp cts> <chan> <temp cts>
<chan> <temp cts> <chan><temp cts> <chan> <temp cts> <chan> <temp cts>
```

COMMAND
COMMAND SYNTAX
ARGUMENTS
DESCRIPTION

SCAN TRIGGER

TRIG

None

This command acts as a software trigger to the DTS. When XSCANTRIG is set to 1, an averaged frame of data will be output when the DTS receives the TRIG command or a <TAB> character code (9 HEX or Control I). This will continue until a STOP command is issued or the Frames per Scan variable is met. The data format will depend upon the setting of EU, BIN and FORMAT.

EXAMPLE 1

A scan command is executed with EU set to 1, BIN set to 0, XSCANTRIG set to 1, and FORMAT set to 0. The DTS will wait for a Hardware trigger, the TRIG command or a <TAB> character (9 HEX or Control I). When one of the Data are scrolled and will be displayed as follows:

```
Frame # <number>  
Time <time> <Fs or ms>  
<chan> <temp eu>  
  "      "  
  "      "  
<chan> <temp eu>
```

For information on other formats, refer to the SCAN command .

COMMAND
COMMAND SYNTAX
ARGUMENTS
DESCRIPTION

SET

SET <name> <value>

<name> - the Configuration Variable to be set or modified.

<value> - the value of that Configuration Variable

Commands the DTS to set one of the many Configuration Variables. Configuration Variables are described in a subsequent section.

NOTE

Listing the Configuration Variables with the LIST command outputs the data in the format required by the SET command. This enables the user to upload data from a file that has been created by a LIST download.

COMMAND
COMMAND SYNTAX
ARGUMENTS
DESCRIPTION

STATUS

STATUS

None

Commands the DTS to send a Status Packet to the client. The Status Packet is described in a subsequent section.

The STATUS command may be entered at any time. This is one of the commands that will not generate an error if entered while the DTS is not READY. The DSM could return one of the following status descriptions

ADCAL	The DTS is calibrating the A/D converters
CAL	The DTS is executing a PT or RPT command
INVALID	The DTS is in an INVALID operating mode.
LIST	The DTS is outputting a configuration variable LIST
OTC	The DTS is testing for open thermocouples
READY	The DTS is operating and ready to accept a command.
SAVE	The DTS is SAVING a configuration
SCAN	The DTS is in the SCAN mode.
UPLOAD	The DTS is UPLOADING a file.

EXAMPLES

If the STATUS command is entered while the DTS is on, but inactive, the DSM will return:

Status: READY

If the STATUS command is entered while the DSM is executing a SAVE command, the DSM will return:

Status: SAVE

COMMAND
COMMAND SYNTAX
ARGUMENTS
DESCRIPTION
RETURNS

STOP

STOP

None

Commands the DTS to abort the current operation.

<nb>

<nb> - end of line.

EXAMPLE

To abort any function or operation:

Type: STOP<CR>

COMMAND	UPLOAD
COMMAND SYNTAX	UPLOAD <S or C><filepath\filename>
ARGUMENTS	S System file to be uploaded C Configuration file to be uploaded
DESCRIPTION	Uploads the specified file to the DTS module. The DTS interprets the type of file based on the file type argument.
RETURNS	<nb> <nb> - end of line.

EXAMPLE	To upload the configuration variable file cv.cfg, located in the DTS files subdirectory on drive c: of the host computer: Type: UPLOAD C c:\DTSfiles\cv.cfg
---------	---

This file will be downloaded from the machine defined by the configuration port settings. The term "host" might be more accurately described as an "FTP Server". This could be the same computer as the host or a different computer somewhere on a network. The relevant settings are:

```
Host Name
Host INET
User
FTP Password
```

NOTE	S or C must be uppercase Refer to the DTS3200 Boot Parameter Modification and DTS Operating System Upload Procedures for more information.
------	---

COMMAND	VERSION
COMMAND SYNTAX	VER
ARGUMENTS	None
DESCRIPTION	Outputs the current software version number.
RETURNS	DTS SHS Scanivalve © 2000 Ver x.xx y x.xx is the software version number. y is the hardware version number

EXAMPLE	To read the current software version: Type: VER<CR> The DTS returns: Version: DTS SHS Scanivalve © 2000 Ver 2.01 1
---------	--

CONFIGURATION VARIABLES

Configuration Variables control the way the DTS functions. The Variables are assigned to one of several groups: SCAN(S), IDENTIFICATION(I), CALIBRATION(C), CHANNEL CORRECTION(P), GAIN(G), OFFSET(O), SETPOINT(P), THERMOCOUPLE(T), RTD CORRECTION(RP), RTD CONVERSION(RTDP), and RTD CALIBRATION(U). Each variable is assigned a "data type" description.

SCAN VARIABLES (Group S)

VARIABLE	AVG <value>
VALID VALUES	1 to 240
DEFAULT VALUE	4
DATA TYPE	integer
DESCRIPTION	This sets the number of raw samples to acquire before producing a filtered output.

VARIABLE	BIN <code>
VALID VALUES	1 or 0
DEFAULT VALUE	0
DATA TYPE	integer
DESCRIPTION	Sets the format of the data packet output. 1 = Binary 0 = ASCII

VARIABLE	FORMAT <code>
VALID VALUES	0, or 1
DEFAULT VALUE	1
DATA TYPE	Integer
DESCRIPTION	Determines if data are to be scrolled on the display. ASCII Output only 0 - data are scrolled 1 - data are displayed in place, formatted for a VT100 terminal.

VARIABLE	FPS <value>
VALID VALUES	0 to 2147483648
DEFAULT VALUE	0
DATA TYPE	long integer
DESCRIPTION	Sets the number of averaged frames to send to the client. If a 0 is entered, the scan will continue until a STOP command is received.

VARIABLE	PERIOD <value>
VALID VALUES	1563 to 31996 Fsec
DEFAULT VALUE	6250
DATA TYPE	integer
DESCRIPTION	Sets the interval between channel samples. NOTE: Periods faster than 6250 microseconds will result in a greater measurement uncertainty. Instrument accuracies listed in the specifications are based on periods of 6250 microseconds or slower.

VARIABLE	QPKTS <code>
VALID VALUES	0 or 1
DEFAULT VALUE	1
DATA TYPE	integer
DESCRIPTION	This switch will control the action the DTS will take when the data buffer is full. 0 - frames will be discarded when the data buffer is full. The DTS will continue to scan. 1 - no frames will be lost. The DTS will stop scanning and log an error if the data buffer is filled.

VARIABLE	TIME <code>
VALID VALUES	0, 1, or 2
DEFAULT VALUE	0
DATA TYPE	Integer
DESCRIPTION	Determines the format of the Time Stamp. 0 - No Time Stamp 1 - Time stamp data are in microseconds 2 - Time stamp data are in milliseconds

VARIABLE	UNITS <type>
VALID VALUES	see list below
DEFAULT VALUE	C
DATA TYPE	string
DESCRIPTION	Engineering Unit conversion type. This can be : A - Volts(Vdc) corrected by the RTD voltage C - degrees Celsius(EC) F - degrees Fahrenheit(EF), K - Kelvin(K) R - degrees Rankin(ER) V - Volts(Vdc) Raw uncorrected 0 - Zero(Raw Counts)

VARIABLE	XSCANTRIG <code>
VALID VALUES	0 or 1
DEFAULT VALUE	0
DATA TYPE	integer
DESCRIPTION	Sets the External Trigger as the Frame Trigger. 0 = the internal clock is the frame trigger 1 = the external trigger is the frame trigger

CHANNEL CORRECTION VARIABLES (Group P)

VARIABLE	PT <channel> <index> <volts applied> <counts applied>
VALID VALUES	Channel - 1 to 16 for channels 1 to 16 Index - 0 to 7 Volts Applied - any valid number Counts Applied - any valid number
DEFAULT VALUE	Channel - 1 to 16 Index - 0 Volts Applied - 0 Counts Applied - 0
DATA TYPE	Channel - Integer Index - Integer Volts Applied - float Counts Applied - Integer
DESCRIPTION	This is the list of setpoints used to calibrate each channel.
EXAMPLE	The List P command is used to view these variables. The variables for each channel are set before the initial factory calibration. The values shown below are for channel 1, but the values will be the same for all channels. <pre> SET PT 1 0 -0.01 -270952 SET PT 1 1 0.00 0 SET PT 1 2 0.07 1896664 </pre> NOTE: The values shown here are values for a perfect module. The actual calibration setpoints may be different.

IDENTIFICATION VARIABLES (Group I)

VARIABLE	AUTOCON <code>
VALID VALUES	0 or 1
DEFAULT VALUE	0
DATA TYPE	integer
DESCRIPTION	Determines if the DTS will automatically convert to a binary receiver. 0 - the DTS will not automatically convert. 1 - the DTS will automatically convert.

VARIABLE	SIM <code>
VALID VALUES	0, or 1
DEFAULT VALUE	0
DATA TYPE	Integer
DESCRIPTION	Determines the source of the data samples. 0 - Data are taken from the sensors 1 - Data are generated internally

VARIABLE	ECHO <code>
VALID VALUES	0 or 1
DEFAULT VALUE	0
DATA TYPE	integer
DESCRIPTION	Determines if characters received from an ethernet host will be echoed back to the host. 0 - the DTS will not echo characters 1 - the DTS will echo characters back to the host.

VARIABLE	HOST <IP address> <port>
VALID VALUES	Any valid IP address Any valid Port
DEFAULT VALUE	IP Address - 0 Port - 0
DATA TYPE	varies
DESCRIPTION	Sets the value of the IP address and port number for binary data for the host computer. If IP Address and Port are set to 0, Binary data are sent out over the TelNet Port. If a server address and port number are defined, Binary data are sent out over that port.

VARIABLE	HOSTCMD <ASCII string>
VALID VALUES	any valid host command
DEFAULT VALUE	0
DATA TYPE	ASCII Strings
DESCRIPTION	Sends the ASCII command string contained in this variable to the host computer binary receiver.

CALIBRATION VARIABLES (Group C)

VARIABLE	CALAVG <value>
VALID VALUES	1 to 64
DEFAULT VALUE	4
DATA TYPE	integer
DESCRIPTION	Determines how much averaging to perform during an A/D Calibration. This setting will have an effect on boot up time.

VARIABLE	NUMPTS <points>
VALID VALUES	1 to 8
DEFAULT VALUE	3
DATA TYPE	integer
DESCRIPTION	Determines the number of setpoints in the channel correction list.

VARIABLE	NUMCOEF <coef>
VALID VALUES	1 to 3
DEFAULT VALUE	3
DATA TYPE	integer
DESCRIPTION	Determines the number of calibration coefficients for the channel corrections. 1 - Offset only 2 - $y = mx + b$ correction curve 3 - $y = ax^2 + bx + c$ correction curve

THERMOCOUPLE VARIABLES (Group T)

VARIABLE	TYPE <channel> <type> [shield connect]
VALID VALUES	channel - the channel number, 0 through 16 type - E, J, K, N, R, S, or T
DEFAULT VALUE	channel - 0 type - J shield connect - 1
DATA TYPE	integer
DESCRIPTION	Determines the thermocouple conversion for each channel. If the channel is entered as 0, all 16 channels will be set to the thermocouple type specified. The shield connection switch should be set based on the method used to ground or shield the thermocouple. If shield connect is set to 0, the switch will be open. The default setting is 1 or closed. Refer to the figures below for more information on how to properly define this parameter.

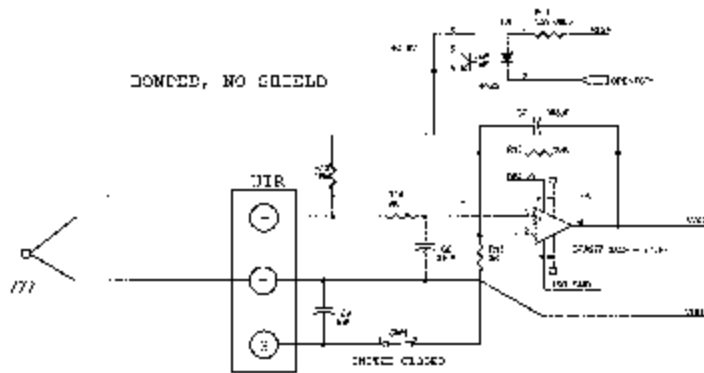

Figure 9 - Bonded Thermocouple, No Shield

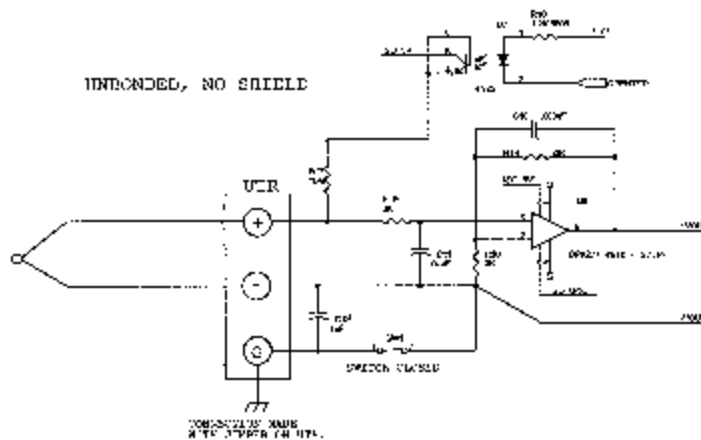

Figure 10 - Unbonded Thermocouple, No Shield

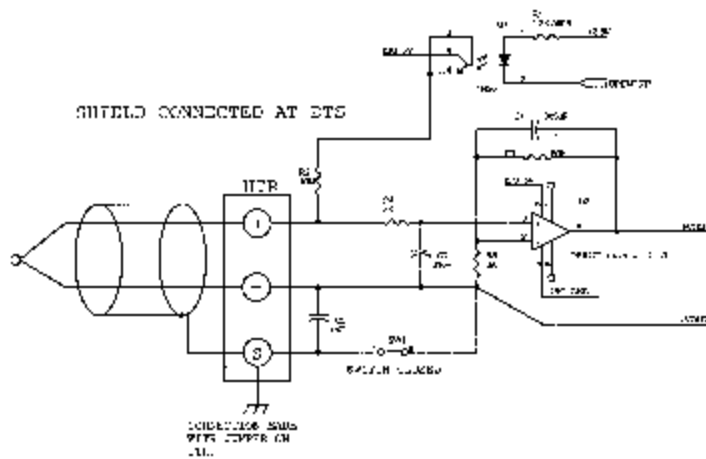

Figure 11 - Shielded Thermocouple, Shield connected at the DTS

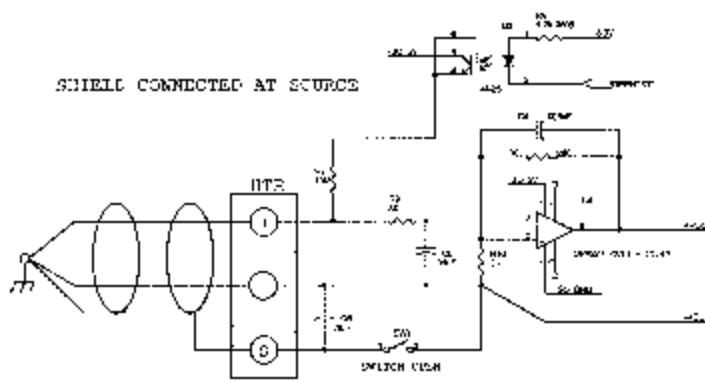

Figure 12 - Shielded Thermocouple, Shield connected at the source

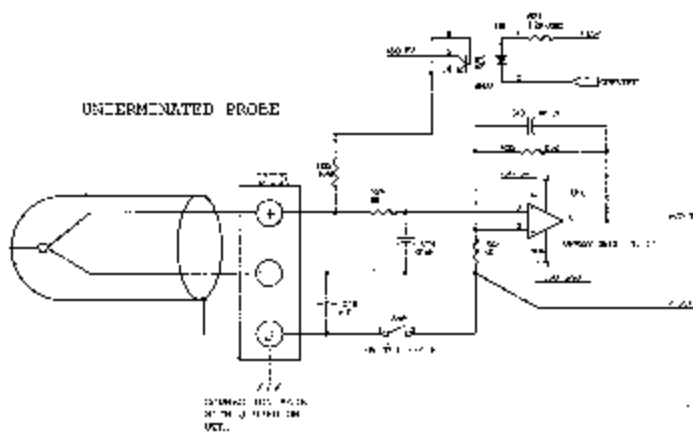

Figure 13 - Unterminated Probe

RTD CORRECTION VARIABLES (Group RP)

VARIABLE	RPT <index> <volts applied> <counts applied>
VALID VALUES	Index - 0 to 7 Volts Applied - any valid number Counts Applied - any valid number
DEFAULT VALUE	Index - 0 Volts Applied - 0 Counts Applied - 0
DATA TYPE	Index - Integer Volts Applied - float Counts Applied - Integer
DESCRIPTION	This is the list of setpoints used to calibrate the RTD's. Both RTD's are corrected by the same setpoints.
EXAMPLE	The List RP command is used to view these variables. The variables are set to the following before the initial factory calibration: SET RPT 0 0.095000 1287022 SET RPT 1 0.105000 1557974 SET RPT 2 0.131000 1774736

NOTE: The values shown here are values for a perfect module. The actual calibration setpoints may be different.

RTD CONVERSION VARIABLES (Group RTDP)

VARIABLE	RTDP <channel> <index> <temp> <ohms>
VALID VALUES	Channel - 1 and 2 Index - 0 to 7 Temp - the temperature in degrees C at the ohms value Ohms - The resistance of the RTD at the indicated temp
DEFAULT VALUE	Channel - 0 and 1 Index - 0 and 1 Temp - 0 and 100 Ohms - 100 and 138.5
DATA TYPE	Channel - Integer Index - Integer Temp - float Ohms - float
DESCRIPTION	This is the list of conversion variables used to convert the resistance of each RTD to degrees C. Both RTD's are corrected by the same number of setpoints and by the same conversion type.
EXAMPLE	The List RTDP command is used to view these variables.
NOTE	When all RTDP setpoints have been entered, a FILL command must be issued to generate RTDM1, RTDM2, RTDB1, AND RTDB2

VARIABLE	RTDNUMPT <points>
VALID VALUES	0 to 8
DEFAULT VALUE	3
DATA TYPE	integer
DESCRIPTION	Determines the number of setpoints in the RTD conversion calculation. If this variable is set to 0, The RTDP variables will not be used. RTDM1, RTDM2, RTDB1, and RTDB2 will be used instead.

VARIABLE	RTDNUMCOEF <coef>
VALID VALUES	2
DEFAULT VALUE	2
DATA TYPE	integer
DESCRIPTION	Determines the type of conversion calculation to be used. Currently only a slope-intercept conversion is enabled. 2 - $y = mx + b$ correction curve

VARIABLE	RTDX1 <value>
VALID VALUES	any real number
DEFAULT VALUE	1.00000
DATA TYPE	float
DESCRIPTION	The conversion factor for RTD1 to convert ohms to millivolts for temperature conversion.

VARIABLE	RTDX2 <value>
VALID VALUES	any real number
DEFAULT VALUE	1.00000
DATA TYPE	float
DESCRIPTION	The conversion factor for RTD2 to convert ohms to millivolts for temperature conversion.

CHANNEL GAIN CORRECTION VARIABLES (Group G)

VARIABLE	GAIN <channel> <gain value>
VALID VALUES	any real number
DEFAULT VALUE	1
DATA TYPE	float
DESCRIPTION	Sets the GAIN correction for a given channel using the formula:

$$\text{Adjusted Counts} = (\text{GAIN} * \text{counts}) + \text{OFFSET}.$$

CHANNEL OFFSET CORRECTION VARIABLES (Group O)

VARIABLE	OFFSET <channel> <gain value>
VALID VALUES	any real number
DEFAULT VALUE	0
DATA TYPE	float
DESCRIPTION	Sets the OFFSET correction for a given channel using the formula:

$$\text{Adjusted Counts} = (\text{GAIN} * \text{counts}) + \text{OFFSET}.$$

RTD CALIBRATION VARIABLES (Group U)

VARIABLE	MAXDELTA <value>
VALID VALUES	any real number
DEFAULT VALUE	.25
DATA TYPE	Integer
DESCRIPTION	This is the maximum allowable difference between the readings of RDT1 and RTD2 in degrees C. If MAXDELTA exceeds this setpoint, an error is logged and bit 12 is set in the general status element of the data packet.

VARIABLE	RNUMPTS <points>
VALID VALUES	1 to 8
DEFAULT VALUE	3
DATA TYPE	integer
DESCRIPTION	Determines the number of setpoints in the RTD correction list.

VARIABLE	RNUMCOEF <coef>
VALID VALUES	1 to 3
DEFAULT VALUE	3
DATA TYPE	integer
DESCRIPTION	Determines the number of calibration coefficients in the RTD correction list. 1 - Offset only 2 - $y = mx + b$ correction curve 3 - $y = ax^2 + bx + c$ correction curve

VARIABLE	RTDB1 <value>
VALID VALUES	any real number
DEFAULT VALUE	-259.7403
DATA TYPE	float
DESCRIPTION	The "B" term in the conversion equation used to convert RTD #1 millivolts to degrees Celsius. The conversion formula is:

$$EC' \text{ millivolts} (rtdM\%rtdB$$

VARIABLE	RTDB2 <value>
VALID VALUES	any real number
DEFAULT VALUE	-259.7403
DATA TYPE	float
DESCRIPTION	The "B" term in the conversion equation used to convert RTD #2 millivolts to degrees Celsius. The conversion formula is:

$$EC' \text{ millivolts} (rtdM \% rtdB$$

VARIABLE	RTDM1 <value>
VALID VALUES	any real number
DEFAULT VALUE	2.59703
DATA TYPE	float
DESCRIPTION	The "M" term in the conversion equation used to convert RTD #1 millivolts to degrees Celsius. The conversion formula is:

$$EC' \text{ millivolts} (rtdM \% rtdB$$

VARIABLE	RTDM2 <value>
VALID VALUES	any real number
DEFAULT VALUE	2.597403
DATA TYPE	float
DESCRIPTION	The "M" term in the conversion equation used to convert RTD #2 millivolts to degrees Celsius. The conversion formula is:

$$EC' \text{ millivolts} (rtdM \% rtdB$$

DTS Packet Definitions

When requested the DTS sends an application packet to the client. Each packet sent to the client starts with a Packet Type Word. This word defines the packet type.

Packet Type Table

PACKET NAME	PACKET ID	BYTES	NOTES
Data	0Hex	168	
Host Control	1Hex	168	
Scan Raw	4Hex	70	Transmits Temperature data in binary, raw counts.
Scan EU	5Hex	104	Transmits Temperature data in binary, engineering units.
Scan Raw -Time	6Hex	38	Transmits Temperature data in binary, raw counts with a time stamp.
Scan EU - Time	7Hex	72	Transmits Temperature data in binary, engineering units with a time stamp.
ASCII	20Hex	Variable	Text Packet may be formatted or un-formatted. The format is determined by the setting of the FORMAT Configuration Variable. NOTE: When the first integer of the packet is 20Hex or greater, the packet is assumed to be in ASCII FORMAT.

Host Control Packet: Type 1

Command Packet

FUNCTION DESCRIPTION	BYTES	DESCRIPTION
Packet Type	4	0 = Data Packet, 1 = Host Control
Host ASCII Command Data (Refer to the Command Section of this manual for more information)	164	ASCII string received by DTS as the Host command. Each line must be terminated with a CR, LF, CR-LF or LF-CR.

DTS to HOST Data Packet

FUNCTION	BYTES	DATA TYPE	DESCRIPTION
Packet Type	4	Integer	0Hex
General Status	4	Integer	Bits 0 - 3: Mode 0 - Ready 1 - Scan 2 - Upload 3 - Save 4 - List 5 - 15 Not Used Bits 4 - 6: Units 0 - Raw 1 - Celsius 2 - Fahrenheit 3 - Roenken 4 - Kelvin 5 - 7 Not Used Bit 7: Last Frame, if set Bit 8: Time Base 0 - microseconds 1 - milliseconds Bits 9 - 31: Not Used
Frame Number	4	Integer	The current frame number if in the scan mode
Temperature 1 to 16	64	Float	Channel temperatures in units set by bits 4 - 6 of the General Status Bytes.
RTD1 Temperature	4	Float	RTD1 temperature in Raw counts or degrees Celsius.
RTD2 Temperature	4	Float	RTD1 temperature in Raw counts or degrees Celsius.
Time Stamp	4	Float	Time in units set by bit 8 of the General Status Bytes.
Channel Status 1 to 16	64	Integer	Bits 0 - 4: Thermocouple Type Bits 5 - 15: Error Codes Bits 16 - 31: Not Used
Spares	16	Integer	Spares

ASCII Packet

This packet will be transmitted when the host issues one of the following commands:

- 1) SCAN with BIN set to 0
- 2) LIST n
- 3) ERROR
- 4) STATUS

FUNCTION DESCRIPTION	BYTES	DATA TYPE	VALUE
ASCII Data (The first two bytes must NOT be 1Hex through 1FHex). Refer to the Command Section of this manual for the proper Command return formats.	1 to 1492	String	Unique to Packet. Each line is terminated with a CR, LF, CR-LF, or LF-CR.

Network Protocols Supported

Physical Layer : 10Base-T IEEE 802.3
Link Layer: INTERNET Protocol (IP)
Transport Layer: Transmission Control Protocol (TCP)
User Datagram Protocol (UDP)

Special Operational Notes

1. If any RTD reading is outside the range -10.0 °C to 70.0 °C, the last good reading is used. NO error will be logged.
2. If any thermocouple reading is outside the range -200.0 °C to 1800 °C, the last good reading is used. NO error will be logged.
3. If any A/D converters are disabled due to errors, an error will be logged and bit 12 of the channel status element in the data packet will be set.

DTS3250 Boot Parameter Modification

The DTS3250 Series modules use an operating system licensed from VxWorks. The boot parameters are set at the factory, but these parameters may be modified to suit the needs of a specific installation. This section documents the modification of the boot parameters.

1. De-energize the DTS3250. Connect the DTS3250 trigger/serial test cable (Scanco part #155829) from the DTS3250 to a host PC.
2. Start HyperTerminal, or an equivalent communication program. Connect the DTS3250 to a COM port on the PC Host. Set the serial parameters to 9600 BAUD, no parity, 8 data bits and 1 stop bit.
3. Energize the DTS3250. The following sign-on information should be displayed.

```
VxWorks System Boot
Copyright 1984-1997 Wind River Systems, Inc.
```

```
CPU: HITACHI hs7709
Version: 5.3.1
BSP version: 1.1/0
Creation date: Feb 9 2000, 12:41:05
```

```
Scanivalve (c)2000, Boot loader version 1.01
Press any key to stop auto-boot...
```

4. Press any key within 3 seconds to stop the auto-boot process. If a key is not pressed within the 3 seconds time, the system will proceed to auto-boot with the existing operating system using the current setup.

NOTE: The boot-loader will continue to reboot until stopped by pressing a key under the following conditions:

- A. If boot-from-flash is selected, and no operating system is present in flash.
 - B. if boot-from-net is selected and the FTP server is not correctly set up.
5. When the auto-boot process is stopped, the boot-loader will prompt with:

```
[VxWorks Boot]:
```

To get a list of the existing boot parameters:

```
Type: p <Enter>
```

The following list is the default setup:

```
boot device           : cs
processor number      : 0
host name             : host
file name             : c:/DTS_hs/vxWorks.st
inet on ethernet (e) : 191.30.80.100
host inet (h)        : 191.30.101.109
user (u)             : DTS_HS
ftp password (pw)    : scanivalve
flags (f)            : 0x0
other (o)            : flash,000.096.093.218.000.002,10baseT
```

6. Modify the parameters as required by typing the change command at the [VxWorks Boot] prompt
Type: c<Enter> The boot-loader prompts you for each parameter.

If a particular field has the correct value and does not need to be changed,
Press: <Enter>
NOTE: If any other key is pressed, that will replace the existing information.

To clear a field,
Type: . <Enter>

To quit before viewing all of the parameters,
Type: CTRL+D.
7. After all changes have been made, verify the settings:
Type: p<Enter> The settings are saved in flash at this point.
8. Restart the operating system, with the new settings,
Type: @<Enter> This is the "Load and Go" command.
9. If the DTS3250 boots correctly, de-energize the DTS3250 and disconnect the serial test cable.
10. Re-apply power to the DTS3250.

Boot parameters and their functions:

boot device	Must not be changed from cs
processor number	Must not be changed from 0
host name	Must not be changed from host.
file name	The full pathname of the operating system file name to be booted from, when booting from the network. The default path and file in this line is the path and file used at Scanivalve.
inet on ethernet(e)	The IP address of this DTS3250. The subnet mask may be specified when entering this parameter by entering a colon followed by the subnet mask in hex notation. I.e. 191.30.85.100:FFFFFF00
inet on backplane (b)	Must be left blank
host inet (h)	The IP address of the host to boot from.
gateway inet (g)	The IP address of a gateway node if the host is not on the same network as the DTS3250.
user (u)	The user name that the DTS3250 uses to access the host. This is the name that must be set up in the FTP server on the host. The FTP server must be set up to provide that user name with the proper permission to read from the host directory and the password must be set correctly.
ftp password (pw)	The user password. This must be supplied to boot from host.
flags (f)	Must be 0x0
target name (tn)	Must be blank
startup script (s)	Must be blank
other (o)	This specifies the place to boot from, the MAC address, and the network media. The line must not contain any spaces and each parameter is separated by a comma. The syntax is: <bootloc>,<mac address>,<media type> Valid values are case sensitive and are as follows: <bootloc> net - Boot from network flash - Boot from flash. <mac address> ddd.ddd.ddd.ddd.ddd.ddd <media type> 10base2 - 10Base2 type 10baset - 10BaseT type

DTS3250 Operating System Upload

This section describes the method for upgrading and uploading a new operating system to the DTS3250. Two programs are used in the DTS3250, the boot-loader and the operating system/DTS3250 application, referred to as the operating system.

The purpose of the boot-loader is to start the operating system from local flash or from a location on the network, such as a disk file on a host PC and to allow setting of certain key operating system parameters. The boot-loader can only be installed with special flash programming equipment. However, the boot-loader, under most normal upgrade conditions, would not need to be changed.

When upgrading a new DTS3250 operating system, the following procedure should be followed:

1. Install an FTP server, on your host PC. Scanivalve Corp recommends the War Daemon FTP Server. The installation is described in the FTP Server Installation/Configuration Procedure.
2. Use the boot parameter modification procedure to modify the boot parameters:
 - A. Change the file name parameter to the location of the vxWorks.st file.
 - B. Insure that the user parameter is set to DTS_HS. It must match the user in the FTP server. This name may be modified by a user
 - C. Set the password to scanivalve. It must match the password in the FTP server. The password may be modified by a user.
3. Connect to the DTS3250 using TelNet
4. Issue the "UPLOAD S <full file path>" command from TelNet. Only back slashes can be used in the path name and the S must be upper case.
5. Monitor the operation with the STATUS command. When it returns READY, the upload is complete. The upload will require about 2.5 minutes to complete. If READY is returned immediately, something has been entered incorrectly.
6. When the DTS3250 returns READY, The new operating system is installed in flash memory, but not in RAM.
7. The new operating system will be effective when power is recycled.

DTS3250 Buffer Description

The DTS3250 buffer is a software buffer. It is set up as a FIFO. It is factory set to hold 10000 averaged frames of data. Each frame uses 292 bytes of memory.

The software buffer is always in use regardless of the setting of QPKTS variable. The effect of QPKTS occurs when the buffer is filled. If QPKTS is set to 1, the scan will stop when the buffer is full. If QPKTS is set to 0, subsequent frames will be discarded when the buffer is full.

The buffer is the liaison between the scan task and the scan output task. The scan output task has a higher priority than the scan task. Under initial conditions, when the buffer is empty, the scan task places one frame of data in the buffer. It then signals the scan output task to read the buffer until it is empty. However, when multiple frames of data are in the buffer, the output task continues until the buffer is empty. Multiple frames of data will accumulate if the scan output task is blocked by the network while outputting data.

WarFTP Server

Installation

- Copy the file: Warftp.exe into a temporary directory.
 - Double click: Warftp.exe to unzip the installation files.
 - Double click: Setup.exe
- A window will open prompting for an installation directory. Click Next.

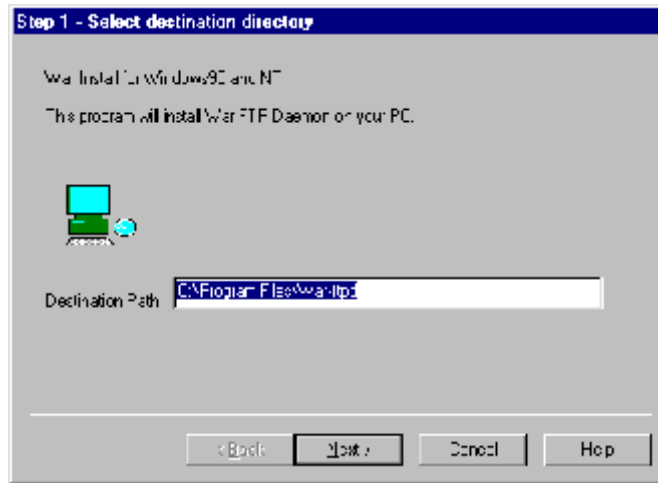

- A window will open prompting for an installation type.
- Select: Typical, and click Next.

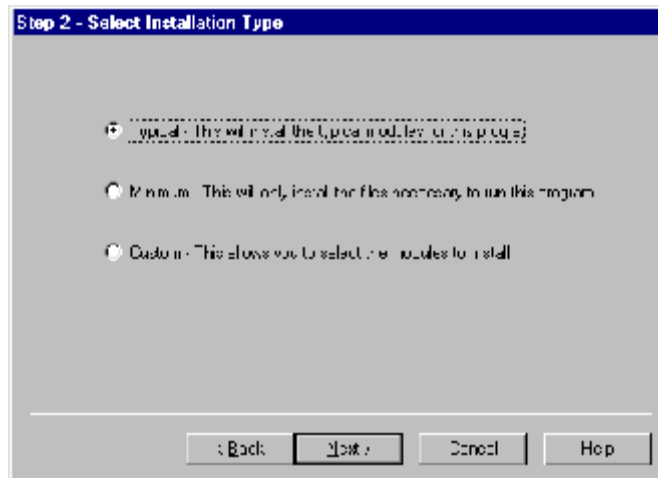

A Window will open prompting for a program folder. Use the default folder, and click Next.

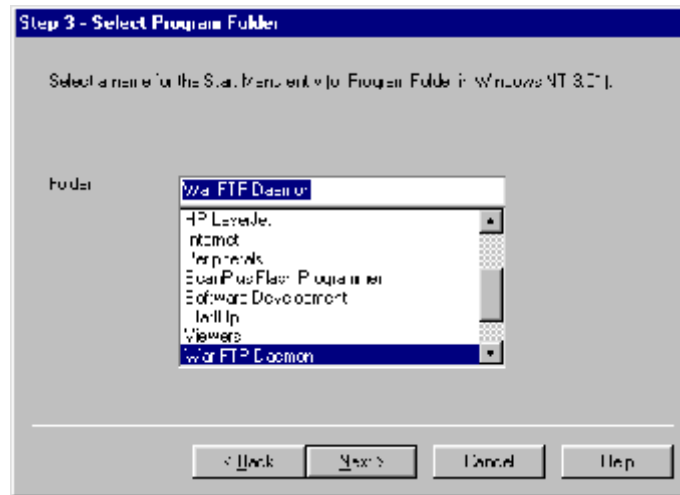

A window will open prompting to finish the installation.
Click: Finish to complete the installation.



If the installation is successful, a window will open with this message. Click OK



Create a folder for the DTS files.

Create the directory: C:\DTS_HS.

Copy the file: VxWorks into this directory.

Configuration and Setup

Start the application by double clicking the war-ftpd.exe icon in the C:\Program Files\War-ftp directory.

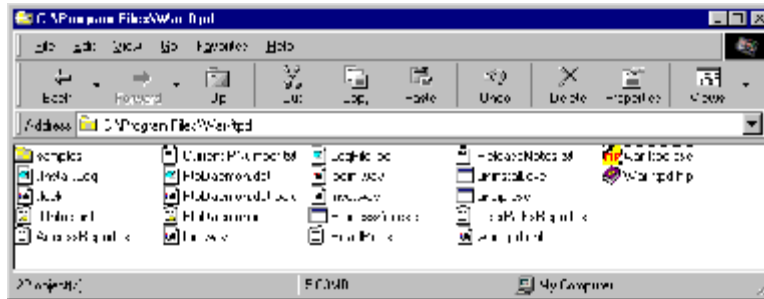

The War FTP Daemon information window will open

Enable the "Do not show this banner again" check box and click OK.



The main display window will open. It will look similar to the window below.

Select: Properties

Select: Options

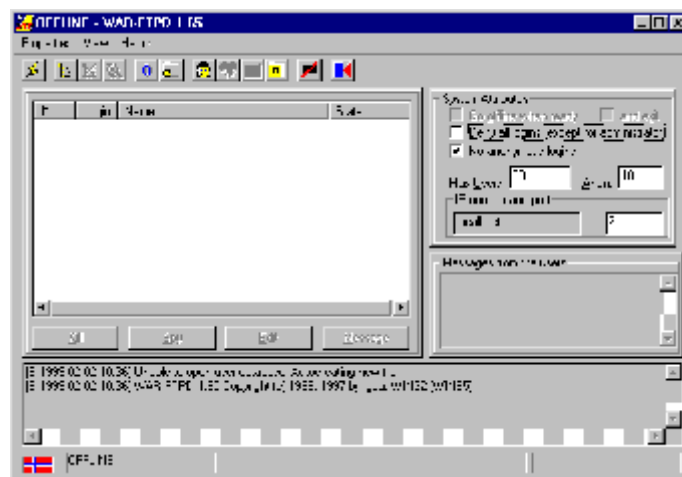

From the General Tab, Enable the "Go online when started and minimize" check boxes.
Select the Server Name Tab.

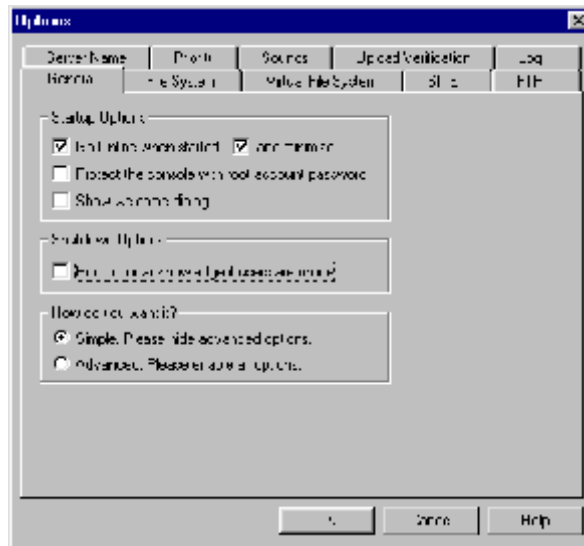

Enter a name for the FTP server.
In this example the server will be named : host.
Click OK.

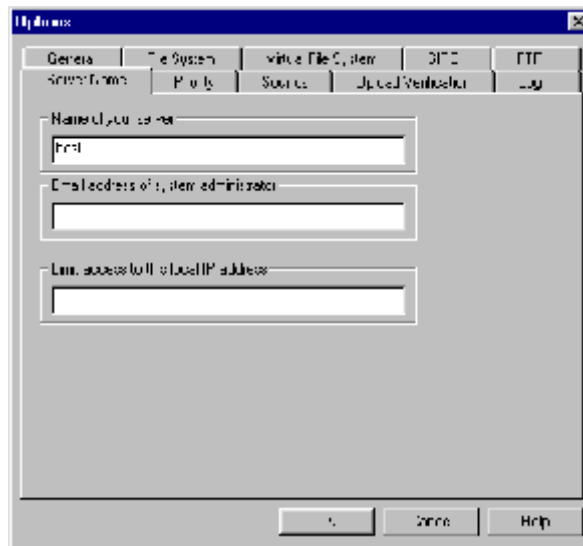

The main window will re-open
 Open the User Maintenance window:
 Click on the large smiling face icon

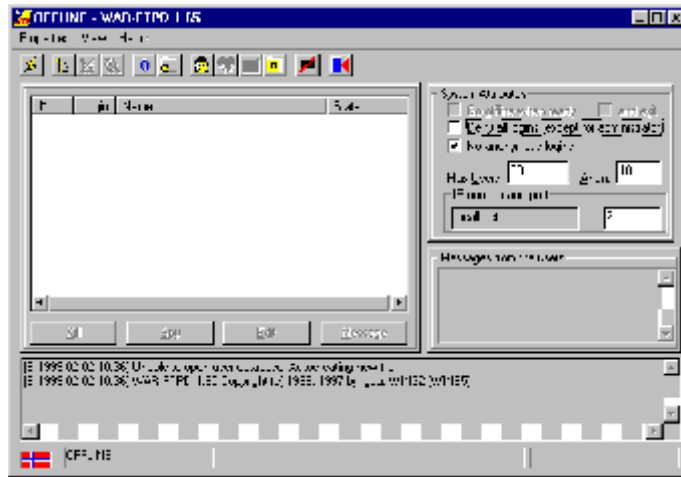

When the User Maintenance Window opens,
 Click the Add button

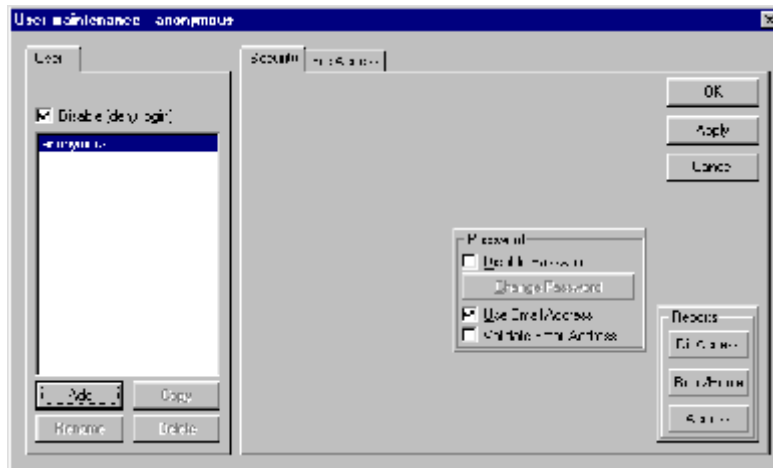

A window will open prompting a User name for the DTS
 Enter a user name for the DTS.
 For this example, the User Name will be: DTS_HS
 Click OK.

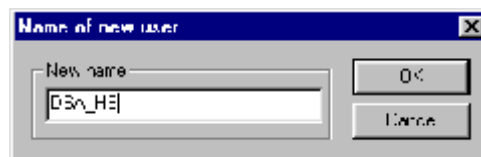

Another window will open prompting for a password
Enter a password for the DTS.
For this example, the password will be: scanivalve.
Click OK.

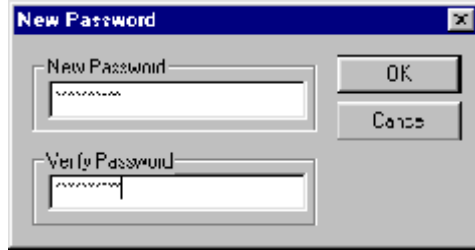

The User Maintenance window will re-open.
Highlight DTS_HS
Select the File Access Tab
Click on the Add Button.

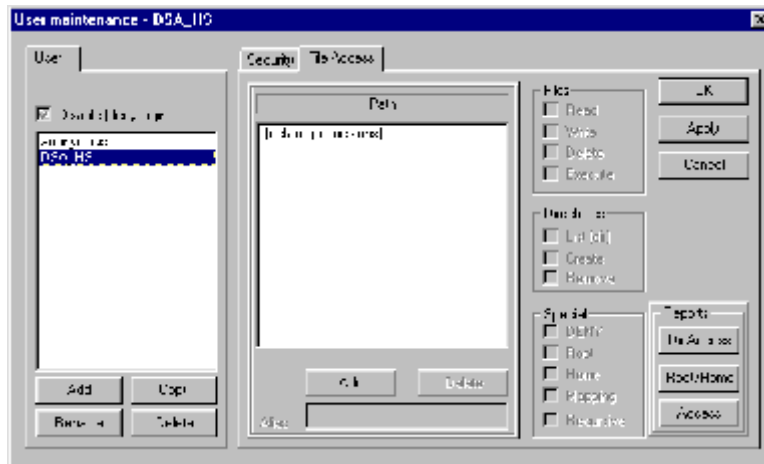

A Select Directory Window will open
Highlight the DTS_HS directory.
Click OK.

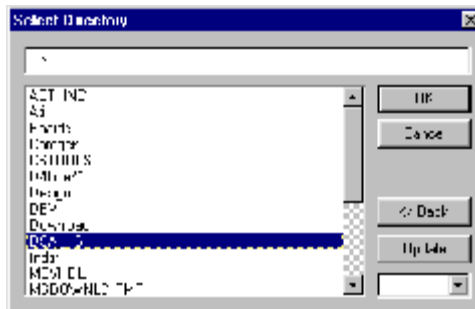

Enable the Read and Write checkboxes in the Files frame.

Click : Apply

Click: OK

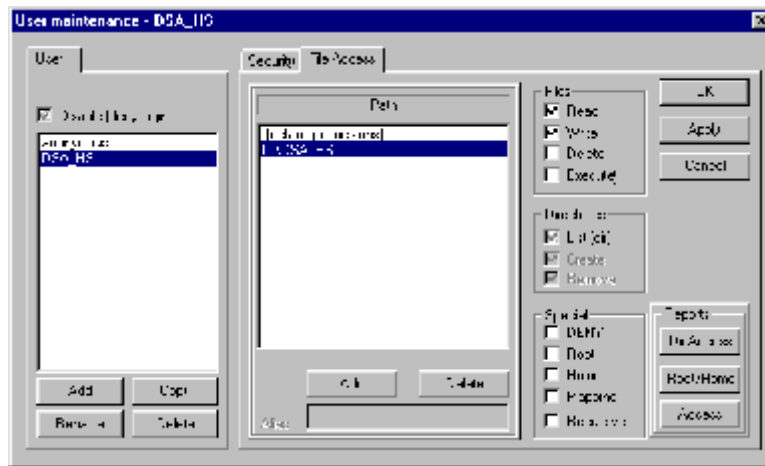

The Main Window will re-open

Put the server online:

Click on the lightning bolt..

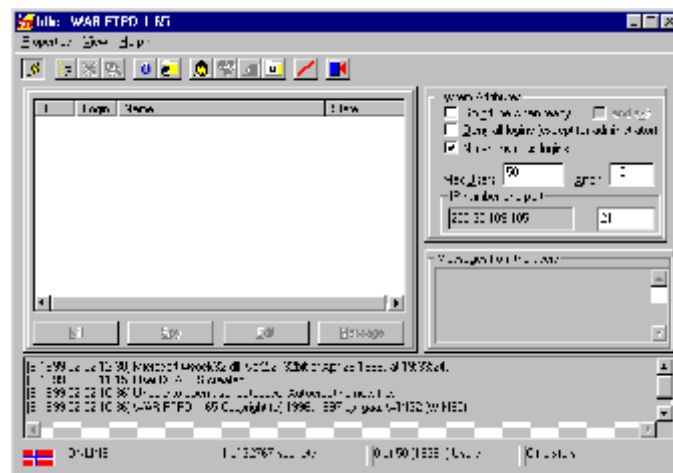

The WarFTP server is now ready

The server can be started manually as needed, or it could be configured to start automatically by placing a shortcut to War-Ftpd.exe in the Windows/Start Menu directory.

Appendix A - DTS Data Flow

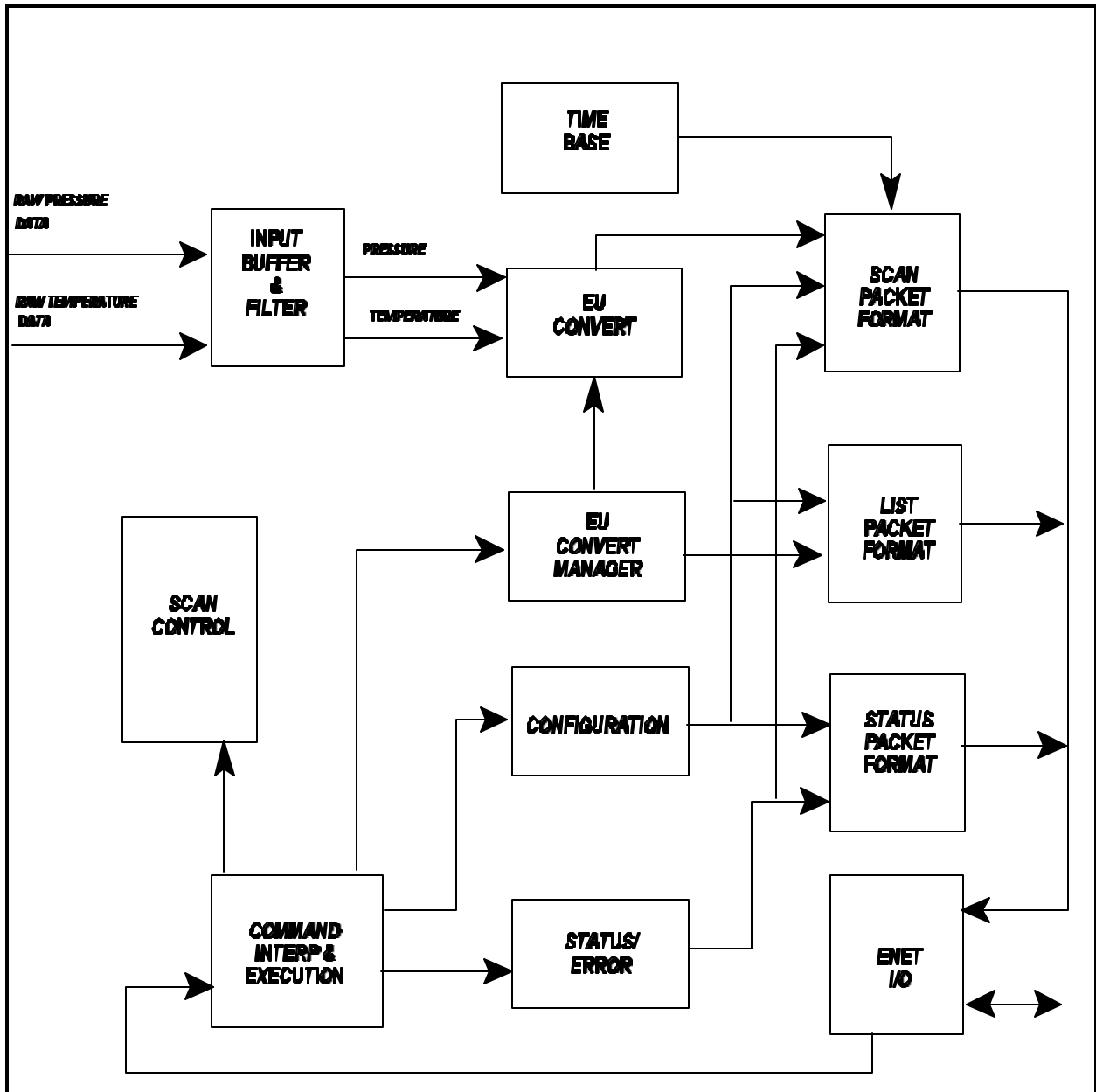

Appendix B - Thermocouple Information

Thermocouple Basics

When two dissimilar metals are joined together to form a closed loop, and if one junction is held at a different temperature from the other, an Electromotive Force (EMF) is generated. The amount of EMF generated is predictable based on the materials used and the temperature of the junction.

The EMF is generated by the wires, not the junction. A temperature gradient must exist before the EMF can be generated.

Three laws have been established that govern thermoelectric circuits.

Law of Homogeneous Materials

A thermoelectric current cannot be sustained in a circuit of a single homogeneous material, however it varies in cross section, by the application of heat alone.

Simply stated, two different materials are required for any thermocouple circuit. If current can be detected in a homogeneous wire when it is heated, this is evidence that the wire is inhomogeneous.

Law of Intermediate Materials

The algebraic sum of the thermoelectromotive forces in a circuit composed of any number of dissimilar materials is zero if all of the circuit is at a uniform temperature.

This law states that a third homogeneous material can be added to a circuit with no effect on the net EMF of the circuit as long as temperature of the junctions remain the same.

Law of Successive or Intermediate Temperature

If two dissimilar homogeneous materials produce a thermal EMF of E_1 when the junctions are at temperature T_1 and T_2 , and a thermal EMF of E_2 when the junctions are at T_2 and T_3 , the EMF generated when the junctions are at T_1 and T_3 will be $E_1 + E_2$.

This law states that a thermocouple calibrated for one reference temperature can be used with any other reference temperature with a correction. Also, extension wires having the same characteristics as those of the thermocouple wires can be introduced to the circuit without affecting the circuit.

Thermocouple Circuits

A basic thermocouple circuit consists of two dissimilar homogeneous materials extending from the measuring junction to the reference junction.

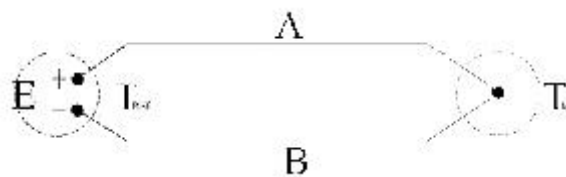

When more than one thermocouple is to be measured, each thermocouple should be two continuous wires between the measuring and reference junctions. This is the most common circuit for thermoelectric testing.

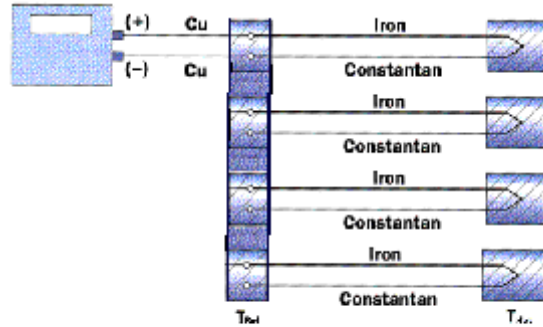

Thermocouple Accuracy

Thermocouple accuracy can be defined as relative and absolute accuracy.

Relative Accuracy

This is the ability of the system to repeat a given measurement. This depends upon the quality of the sensors, the measuring system used and how the system is installed.

Absolute Accuracy

This is the ability of the system to determine a standard accepted value. This can be achieved by calibration relative accepted and recognized standards.

Thermocouple Calibration

Calibration will not change the characteristics of a thermocouple. It does validate the system and ensure proper readings by allowing corrections to be entered for each thermocouple in the system. Calibrations should conform to ISO 10012-1:1992.

Sources of Error in Thermocouple Measurements

Measuring Junction

The thermocouple junction at the temperature measuring point is the measuring junction. Errors at this point depend upon the age of the junction, the method of joining and materials used to form the junction. Generally, errors from the measuring junction are small.

Extension Wires

Extension wires are any elements inserted between the measuring junction and the reference junction. Extension wires should have the same characteristics as the thermocouple wire. Extension wires introduce four junctions to each circuit. This can cause errors as large as ± 2 EC. The errors can be minimized by calibrating the system with the extension wires in place. If possible, extension wires should not be used.

Reference Junctions

The thermocouple junction maintained at a known temperature is the reference junction. Reference junctions can introduce errors as large as ± 0.6 EC.

Copper Connecting Wires

These wires are used to connect the reference junction to the measuring device. The errors caused by these wires are very small.

Thermocouple Switches

When used, these devices can induce errors as large as ± 1 EC. Switching should occur in the copper wires between the reference junction and the measuring device.

Noise in Thermocouple Circuits

The external effects that can cause errors in thermocouple circuits include: electrical and magnetic fields, cross-talk, and common mode voltage.

Electric fields radiated from voltage sources are capacitively coupled to thermocouple extension wires. This imposes an AC voltage on the thermoelectric EMF. This can be minimized by shielding the thermocouple extension wire and grounding the shield.

Magnetic fields produce noise current in the thermocouple extension wire. This can be minimized by twisting the thermocouple extension wire pairs.

In a multipair thermocouple extension wire, adjacent pairs can pick up noise from a pulsating signal. This can be minimized by shielding the individual pairs.

Common mode noise will be generated if a grounded thermocouple is connected to a grounded instrument. This can be minimized by grounding the thermocouple and shield as close as possible to the measuring point.

Thermocouple Design

The thermocouple used in an application should be selected specifically for the application.

Size

The temperature sensed will be the average temperature across the length of the sensor.

Shape

The shape must conform to the shape of the surface if the thermocouple is measuring surface temperatures.

Response

The response time of a thermocouple is mass dependent. Therefore the size of the thermocouple must be small in relation to the object being measured. The response time should be approximately 5 times shorter than the fastest rate of temperature change to be monitored.

Heat Conduction

Thermocouple extension wires can conduct heat into or out of the thermocouple. The wire must be insulated from the environment if this can occur.

Sensor Position

The thermocouple measures the temperature of the object it is touching or the environment in which it is installed. Therefore the thermocouple must be positioned very carefully to insure that the temperature is being sensed at the correct point.

Thermocouple Types and Descriptions

The DTS family of Temperature Scanners will accept inputs from Type E, J, K, N, R, S, and T Thermocouples. The accuracy of the measurement will depend upon the type of thermocouple and the quality of the extension wire used for the measurement.

Type E - Chromel Constantan

Positive leg	90% nickel, 10% chromium
Negative leg	43% nickel, 57% copper
Range	-270 to 1000 EC
Usable range	0 to 900 EC
Notes	Highest EMF output per degree of all recognized thermocouples. Has similar drift between 316 and 593 EC as a Type K thermocouple

Type J - Iron Constantan

Positive leg	100% iron
Negative leg	43% nickel, 57% copper
Range	-210 to 1200 EC
Usable range	0 to 816 EC
Notes	Not susceptible to aging from 371 to 538 EC. Very stable, should be used with a 96% pure MgO insulation and stainless steel sheath to prevent corrosion of the iron lead. Most commonly used thermocouple.

Type K - Chromel Alumel	
Positive leg	90% nickel, 10% chromium
Negative leg	95% nickel, 2% aluminum, 2% manganese, 1% silicon
Range	-270 to 1372 EC
Usable range	-36 to 1260 EC
Notes	Not recommended from 316 to 593 EC because of aging that can cause drift rates of 2 EC in a few hours. Best used when corrosion may be a problem.
Type N	
Positive leg	14% chromium, 1.4% silicon, 84.6% nickel
Negative leg	95.6% nickel, 4.4% silicon
Range	-270 to 1372 EC
Usable range	0 to 1260 EC
Notes	Less aging from 316 to 593 EC than a Type K thermocouple.
Type R	
Positive leg	87% platinum, 13% rhodium
Negative leg	100% platinum
Range	-50 to 1767 EC
Usable range	0 to 1482 EC
Notes	Has a higher output than Type S thermocouples. Easily contaminated. This thermocouple should be protected by compacted mineral insulation and a metal outer sheath.
Type S	
Positive leg	90% platinum, 10% rhodium
Negative leg	100% platinum
Range	-50 to 1767 EC
Usable range	0 to 1482 EC
Notes	Easily contaminated. This thermocouple should be protected with a gas tight ceramic tube, a secondary tube of porcelain and a silicon carbide or metal outer tube.
Type T - Copper Constantan	
Positive leg	Pure copper
Negative leg	43% nickel, 57% copper
Range	-270 to 400 EC
Usable range	-262 to 350 EC
Notes	Good for low temperature and cryogenic applications

International Thermocouple and Extension Wire Color Codes

Country	USA	USA	United Kingdom	United Kingdom	Germany	Japan	France
Standard	ANSI MC96.1 T/C	ANSI MC96.1 Extension	BS 1843	BS 4937	DIN 43714	JIS C1610-1981	NFE C42-323
E Overall E Positive E Negative	Brown Purple Red	Purple Purple Red	Brown Brown Blue	Brown Brown Blue	Black Red Black	Purple Red White	-----
J Overall J Positive J Negative	Brown White Red	Black White Red	Black Yellow Blue	Black Black White	Blue Red Blue	Yellow Red White	Black Yellow Black
K Overall K Positive K Negative	Brown Yellow Red	Yellow Yellow Red	Red Brown Blue	Green Green White	Green Red Green	Blue Red White	Yellow Yellow Purple
N Overall N Positive N Negative	Brown Orange Red	Orange Orange Red	-----	-----	-----	-----	-----
R Overall R Positive R Negative	-----	Green Black Red	Green White Blue	Orange Orange White	White Red White	Black Red White	Green Yellow Green
S Overall S Positive S Negative	-----	Green Black Red	Green White Blue	Orange Orange White	White Red White	Black Red White	Green Yellow Green
T Overall T Positive T Negative	Brown Blue Red	Blue Blue Red	Blue White Blue	Brown Brown White	Brown Red Brown	Brown Red White	Blue Yellow Blue

Appendix C - DTS 3250 Calibration Procedure

Introduction

A Digital Thermocouple Scanner must be calibrated in a very specific order. First the RTD's must be tested and a correction factor calculated. Then the RTD circuit must be calibrated using a voltage source. A voltage source must then be used to input millivolt signals to each of the input channels to verify the accuracy of each channel. Finally, a thermocouple simulator should be used to verify that the conversion algorithm in the software is functioning correctly.

Equipment Required

Secondary Voltage Standard. Accuracy equal to or better than $\pm 0.01\%$ rdg.
Digital Volt/Ohmmeter Accuracy equal to or better than $\pm 0.01\%$ FS
Oven capable of maintaining temperatures from -20EC to 50EC
Scanivalve Field Calibration Kit
Ice Point Reference
Thermocouple Simulator
DTS Hardware and Software Manual

Procedure

1. Set the DTS on a bench and remove the non-conductive cover plates. Disconnect RTD1 from J1 and install the RTD simulator contained in the Field Calibration Kit. Replace the cover plates.

RTD Circuit Calibration

2. Energize the DTS and allow a minimum of 4 hours for warm up.
3. Open a TelNet session on the Host computer and connect to the DTS.
4. Verify the RTD calibration configuration variables.

Type: **LIST C**<Enter>

The DTS should return:

SET NUMCOEF 3

SET NUMPTS 8

SET CALAVG 16

These variables must be set to the values shown.

The **NUMCOEF** and **NUMPTS** terms determine what type of conversion will be used. The **NUMCOEF** term identifies the correction curve and **NUMPTS** identifies the number of calibration points. If **NUMCOEF** is set to 3, the correction will be a second order polynomial. It is recommended that a minimum of 4 calibration points be used with a second order polynomial.

5. Verify the RTD coefficient settings

Type: **LIST U**<Enter>

The DTS will return:

SET RTDM1 xxxxx
SET RTDM2 xxxxx
SET RTDB1 xxxxx
SET RTDB2 xxxxx
SET RNUMCOEF 3 This indicates a second order polynomial correction
SET RNUMPTS 8 This indicates 8 calibration points
SET MAXDELTA 1.000000

Verify that these values match the certification sheet. If the RTD has been re-certified, enter the new coefficients.

6. Calibrate the A/D converters.

Type: **ADCAL**<Enter> The A/D converters will be rezeroed. This will require approximately one minute if the DTS is configured to the settings in step 4.

7. Enter the first calibration point. Connect the Digital Voltmeter to the RTD simulator. Adjust the RTD simulator so the voltmeter reads as close to 95.000 mv as possible.

Record the reading_____ and,

Type: **RPT 0 [millivolt reading]**<Enter>

The DTS will process this point. This will require approximately 8 seconds.

8. Enter the second calibration point. Adjust the simulator so the voltmeter reads as close to 100.000 mv as possible.

Record the reading_____ and,

Type: **RPT 1 [millivolt reading]**<Enter>

The DTS will process this point. This will require approximately 8 seconds.

9. Enter the third calibration point. Adjust the simulator so the voltmeter reads as close to 105.000 mv as possible.

Record the reading_____ and,

Type: **RPT 2 [millivolt reading]**<Enter>

The DTS will process this point. This will require approximately 8 seconds.

10. Enter the fourth calibration point. Adjust the simulator so the voltmeter reads as close to 110.000 mv as possible.

Record the reading_____ and,

Type: **RPT 3 [millivolt reading]**<Enter>

The DTS will process this point. This will require approximately 8 seconds.

11. Enter the fifth calibration point. Adjust the simulator so the voltmeter reads as close to 115.000 mv as possible.
 Record the reading_____ and,
 Type: **RPT 4 [millivolt reading]**<Enter>
 The DTS will process this point. This will require approximately 8 seconds.
12. Enter the sixth calibration point. Adjust the simulator so the voltmeter reads as close to 120.000 mv as possible.
 Record the reading_____ and,
 Type: **RPT 5 [millivolt reading]**<Enter>
 The DTS will process this point. This will require approximately 8 seconds.
13. Enter the seventh calibration point. Adjust the simulator so the voltmeter reads as close to 125.000 mv as possible.
 Record the reading_____ and,
 Type: **RPT 6 [millivolt reading]**<Enter>
 The DTS will process this point. This will require approximately 8 seconds.
14. Enter the eighth calibration point. Adjust the simulator so the voltmeter reads as close to 131.000 mv as possible.
 Record the reading_____ and,
 Type: **RPT 7 [millivolt reading]**<Enter>
 The DTS will process this point. This will require approximately 8 seconds.
15. Verify that all points were entered correctly.
 Type: **LIST RP**<Enter>
 Re-enter any point that was not entered correctly.
16. When all of the points have been entered correctly,
 Type: **FILL**<Enter> Calculate the correction table
 Type: **SAVE**<Enter> Save the data
17. Verify that the RTD millivolt readings are identical:
 Type: **SET UNITS V**<Enter> Change the Unit conversion to raw volts
 Type: **SCAN**<Enter> Display the data
 Use the RTD Simulator to input several voltages and verify the readings
18. Close the TelNet session. De-energize the DTS. Disconnect the RTD simulator and re-connect the RTD. Re-install the phenolic cover plates. Re-apply power to the DTS. Re-open the TelNet session.

Input Channel Calibration

19. Set the engineering unit conversion to millivolts.
20. Bus all of the positive inputs together using tinned copper wire. Bus all of the Negative inputs together using tinned copper wire.
21. Connect the Voltage Standard to the channel inputs.

Type: **LIST C**<Enter>

The DTS will return a list of the calibration setup variables. **NUMCOEF** will give the number coefficients to be calculated. The number 3 indicates a second order polynomial correction. **NUMPTS** lists the number of calibration points to be used. The minimum is 2, the maximum is 8. It is recommended that a second order polynomial be used for the correction with 8 calibration points.

22. The DTS amplifier will operate from -10.000 mv to +70.000 mv. The calibration points should include the voltage extremes. The intermediate points can be equally spaced. For example, an eight point calibration would use -10.000 mv, 0 mv, +12.000 mv, +24.000 mv, +36.000 mv, +48.000 mv, +60.000 mv, and +70.000 mv. A four point calibration would use -11.000 mv, +16.000 mv, +43.000 mv, and 70.000 mv. This procedure assumes that an eight point calibration will be used.
23. Set the Voltage Standard to -10.000 mv.
Type: **PT [channel] 0 .010000**<Enter>
This will enter the first calibration point. The command must be entered in this format only. The DTS will only accept the voltage input as volts, not millivolts. The DTS will require approximately 8 seconds to process the data.
24. Set the Voltage Standard to +0.000 mv.
Type: **PT [channel] 1 .000000**<Enter>
This will enter the second calibration point. The DTS will require approximately 8 seconds to process the data.
25. Set the Voltage Standard to +12.000 mv.
Type: **PT [channel] 2 .012000**<Enter>
This will enter the third calibration point. The DTS will require approximately 8 seconds to process the data.
26. Set the Voltage Standard to +24.000 mv.
Type: **PT [channel] 3 .024000**<Enter>
This will enter the fourth calibration point. The DTS will require approximately 8 seconds to process the data.
27. Set the Voltage Standard to +36.000 mv.
Type: **PT [channel] 4 .036000**<Enter>
This will enter the fifth calibration point. The DTS will require approximately 8 seconds to process the data.

28. Set the Voltage Standard to +48.000 mv.
Type: **PT [channel] 5 .048000**<Enter>
This will enter the sixth calibration point. The DTS will require approximately 8 seconds to process the data.
29. Set the Voltage Standard to +60.000 mv.
Type: **PT [channel] 6 .060000**<Enter>
This will enter the seventh calibration point. The DTS will require approximately 8 seconds to process the data.
30. Set the Voltage Standard to +70.000 mv.
Type: **PT [channel] 7 .070000**<Enter>
This will enter the eighth calibration point. The DTS will require approximately 8 seconds to process the data.
31. Verify that the calibration points were entered correctly for each channel.
Type: **LIST P [channel]**<Enter>
Repeat any point that is incorrect.
32. If the calibration points are correct, fill the calibration table.
Type: **FILL**<Enter>
33. Save the data.
Type: **SAVE**<Enter>

Algorithm Verification

34. If the Thermocouple simulator has the capability to use an external reference junction input, remove the 10-32 screw from the DTS UTR and connect the remote RTD from the Field Calibration Kit.
NOTE: If the Thermocouple simulator cannot use an external reference junction. A correction will have to be applied based on the difference between the reference junction temperature of the simulator and the temperature of the DTS UTR.
35. Connect the T/C simulator to one or more channels.
36. Set the Engineering Unit Conversion to the temperature scale to be tested.
37. Set the Channels to be tested to the type of thermocouple to be tested.
38. Input several temperatures and verify that any errors do not exceed the errors listed in the specifications section of the DTS 3250 Manual. Thermocouple accuracy should only be verified over the normal usable range of any thermocouple type. Refer to the charts in the DST3250 manual or the Scanivalve Corp Pressure/Temperature Handbook for this information.

Appendix D - Change Log

Version 2.00 - Released March 2001
First Release

Version 2.01 - Released March 2001
Added a Software Trigger Function
Modified several default values to facilitate initial factory calibrations
Modified the response of the software to a SET Value command if the Value is not changed
Added STATUS returns when in the Binary mode
Added variables to better calibrate the RTD's
 RTDP
 RTDNUMPT
 RTDNUMCOEF
 RTDX1
 RTDX2
Added a command to list the new variables
 LIST RTDP
Added capability to send Binary data out the TelNet port
Improved the accuracy of the conversion algorithm